



PORTABLE RAP PLANT



5 YEAR
STRUCTURAL
WARRANTY

2 YEAR
EQUIPMENT
WARRANTY

2 YEAR
COMPONENTS
WARRANTY

1 YEAR
OEM PARTS
WARRANTY

CARRIER CHASSIS

- » HD wide flange structural beams
- » W beam block legs placed accordingly along the frame
 - ↳ Four (4) "sets" (8 legs total) of Holland Mark V landing gear
- » Screen Box and Feed Hopper Access
 - ↳ Two (2) access ladders
 - ↳ All hand railing includes necessary kick plates
 - ↳ Walkway surfaces covered with diamond grip checker plate/hoppers and chutes
- » 3/8" Bolster king pin. All brakes, tail & marker lights, flashing amber led strobe lights, reflectors and mud flaps as required. Over-dimensional flag pipes in all 4 corners fitted with corresponding flag
- » Tandem axle suspension
 - ↳ Eight (8) 11R22.5.5 tires on steel budd wheels
 - ↳ 25,000 Lb rated x 77.5" Track axle assemblies fitted with service pots (to assist with pit portability) and automatic slack adjusters
- » Replaceable 60 durometer skirt board rubber including clamp bars where required
- » Grease package consisting of one (1) – two (2) locations on the chassis where head and tail pulley
- » All necessary guards (frame, v-belt and pinch area)
- » Colors are Superior Industries styling

- » Hydraulic package consists of the following:
 - ↳ Supply and installation of 12 vdc electric over hydraulic power unit. Power unit fitted with 10' – 12' long "booster cables" to allow hook-up to customer supplied 12vdc. C/W hd "cat style" master switch to easily allow turning "on & off". Master switch eliminates the "sparking" that typically occurs when hooking up booster cables.
 - ↳ Necessary hydraulic cylinders to hydraulic fold screen discharge conveyor for operation and transportation requirements.
 - ↳ All hydraulic valves, hoses, and fittings. Unit comes completely plumbed, filled with oil, tested and ready for immediate operation

3X8 2 DECK SCREEN

- » Shim adjustable counterweights (for amplitude efficiency)
- » Screen box sub-frame
- » Screen is installed to operate in inclined position
- » 7.5 HP electric motor

8' X 16 FEED HOPPER

- » Feed hopper fitted with a manual tilt grizzly
 - ↳ Hinges provided on both sides
 - ↳ Grizzly adjustable at 2" increments to 4", 6" or 8" opening. Standard factory setting of 6" between bars

- ↳ Bars are of a triangular construction, 3/4" x 4" flat bars on top with 3/8" x 4" flat bar sides
- » Re-inforced sides and all necessary leg supports where required.
- » Exterior sides of feed hopper fitted with "removable panels"
 - ↳ These panels act as "guarding" to prevent access to conveyor and also assist in keeping debris or foreign material from entering the area during operation
- » Manual adjustable gates
- » Manual folding end wings for additional capacity

CONVEYORS

- » 36" belt under hopper
- » 24" screen feed conveyor
- » 24" screen discharge conveyor

OPTIONS

- » Electrical package
 - ↳ Cable sets four (4) motors
 - ↳ Electrical junction box for motor feed cables
 - ↳ Electrical junction box for multi-conductor wire/cable
 - ↳ Additional receptacle installed in empty cavity in receptacle housing
 - ↳ Speed encoder for 36" under hopper conveyor

- ↳ Multipin connections for encoder and torspec control system
- ↳ Connection for torspec control card to plc and existing control system
- ↳ Belt scale system wiring
- ↳ Complete drawing package
- ↳ Labor and commissioning
- ↳ PLC programming
- » Hydraulic "lift-only" leveling jacks package
 - ↳ Supply and installation of four (4) 6" x 22" stroke hydraulic leveling cylinders. Cylinders C/W a 3/4" thick "oscillating" base plate measuring approximately 10" x 10". The swivel pad design helps with uneven footings.
- ↳ All hydraulic valves, hoses, and fittings. Unit comes completely plumbed, filled with oil, tested and ready for immediate operation

- » Electric bin vibrator package
 - ↳ One (1) electric vibrator unit supplied and installed on 8' x 16' hopper

OPERATING DIMENSIONS

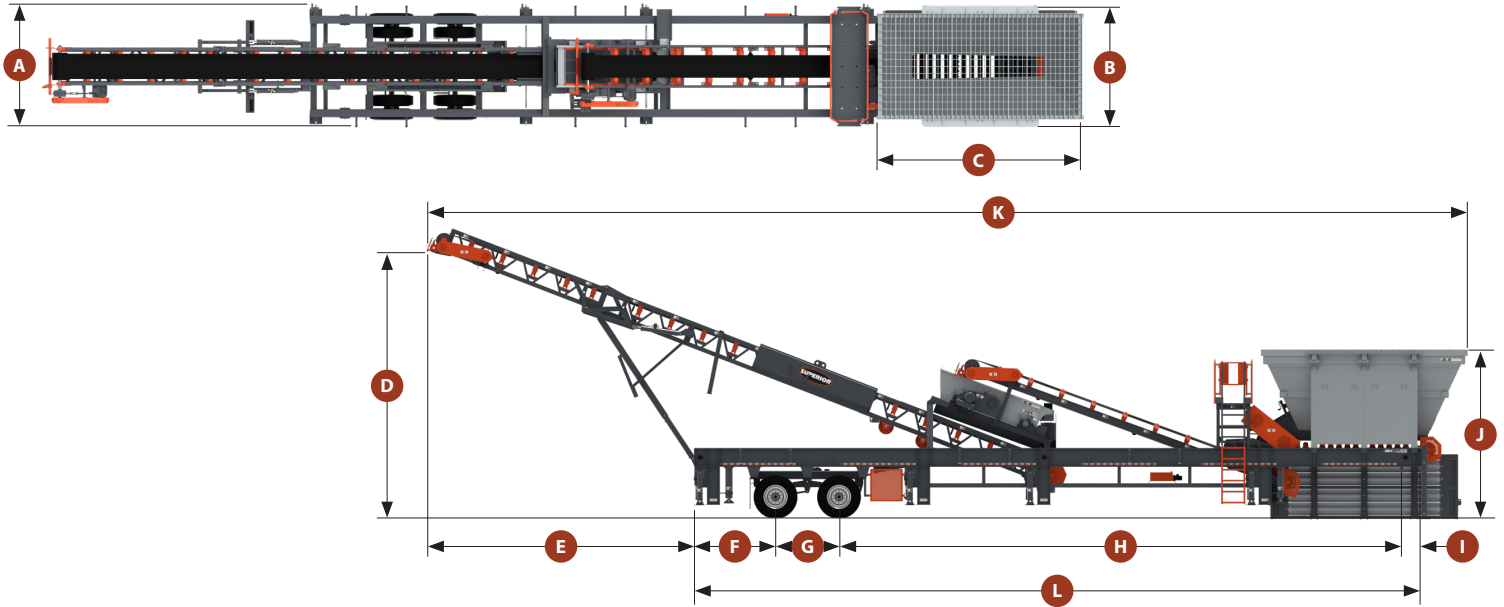

OPERATION DIMENSIONS - INCHES (MM)

A	B	C	D	E	F	G	H	I	J	K	L
118 (2,995)	115 (2,920)	196 (4,980)	240 (6,095)	263 (6,680)	78 (1,980)	61 (1,550)	539 (13,690)	18 (455)	163 (4,140)	1004 (25,500)	696 (17,680)

TRANSPORT DIMENSIONS

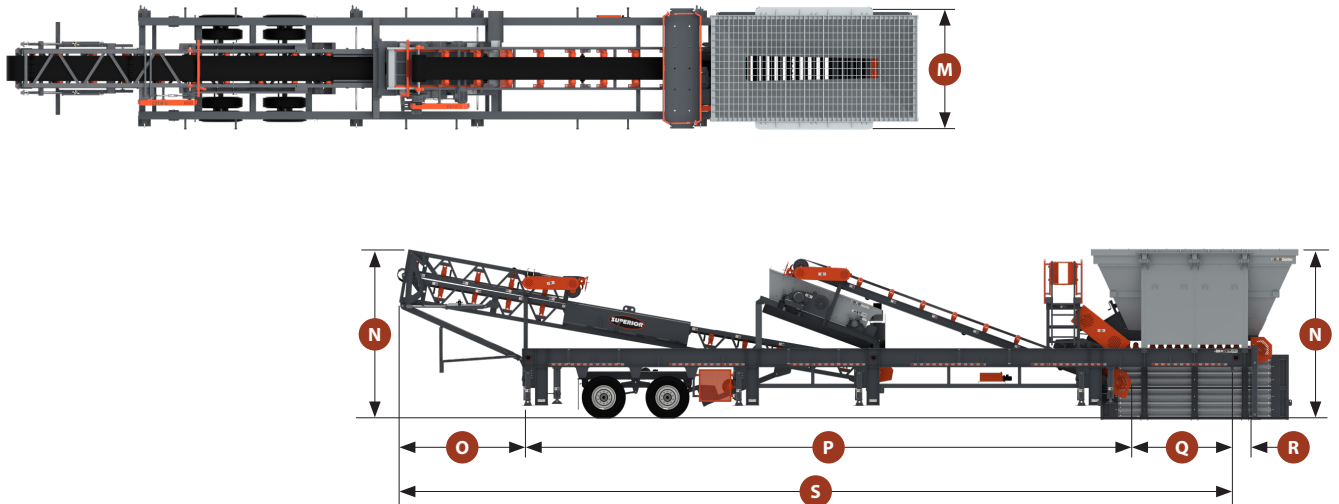

TRAVEL DIMENSIONS - INCHES (MM)

M	N	O	P	Q	R	S
118 (2,995)	162 (4,115)	118 (2,995)	581 (14,755)	96 (2,440)	18 (455)	795 (20,190)