



PATRIOT® CONE PLANT

REAR FEED, REAR DISCHARGE (NS/WS)



MODEL SHOWN: P200 RFRD PATRIOT CONE CRUSHER PLANT

STANDARD FEATURES

PATRIOT CONE CRUSHER

- » Crusher drive motor and base
- » Countershaft blower

CARRIER CHASSIS

- » Superior paint scheme
- » Tridem axle
- » Air brake system
- » Mud flaps
- » Travel lights w/ brake and directional signals
- » Fifth wheel hitch
- » Hydraulic leveling legs
- » Fixed structural cribbing legs
- » Tool box
- » King pin supports
- » Diamond plate walkway w/ drainage holes
- » Access ladders

- » Elevated observation platform
- » Safety guarding*
- » Grease package

HOPPERS AND CHUTES

- » Overflow chute
- » Under flow chute
- » Adjustable rubber flashing

42" REAR FEED CONVEYOR

- » Structural channel frame
- » Hydraulic raise/lower
- » Fold for transport
- » Rear telescoping swing tail support
- » Class II drive
- » Dodge bearings
- » Chevron® Pulley
- » Sealing System
- » CEMA Idlers with

SpinGuard® Seals

- » Vulcanized belt

42" REAR DISCHARGE CONVEYOR

- » Structural channel frame
- » Class II drive
- » Dodge bearings
- » Chevron® Pulley
- » Sealing System
- » CEMA Idlers with SpinGuard® Seals
- » Exterra™ Primary Belt Cleaner
- » Vulcanized belt

OPTIONS

- ★ Level Assist (patent pending)
- ★ Fully removable feed conveyor cartridge
- ★ Vantage™ Automation System
 - » Run on jacks with counterbalance valves
 - » Run on jacks with mechanical pin locks
 - » Control panel
 - » Interlocking controls
 - » Lubrication system

★ Exclusive to Superior Industries

OPERATING DIMENSIONS

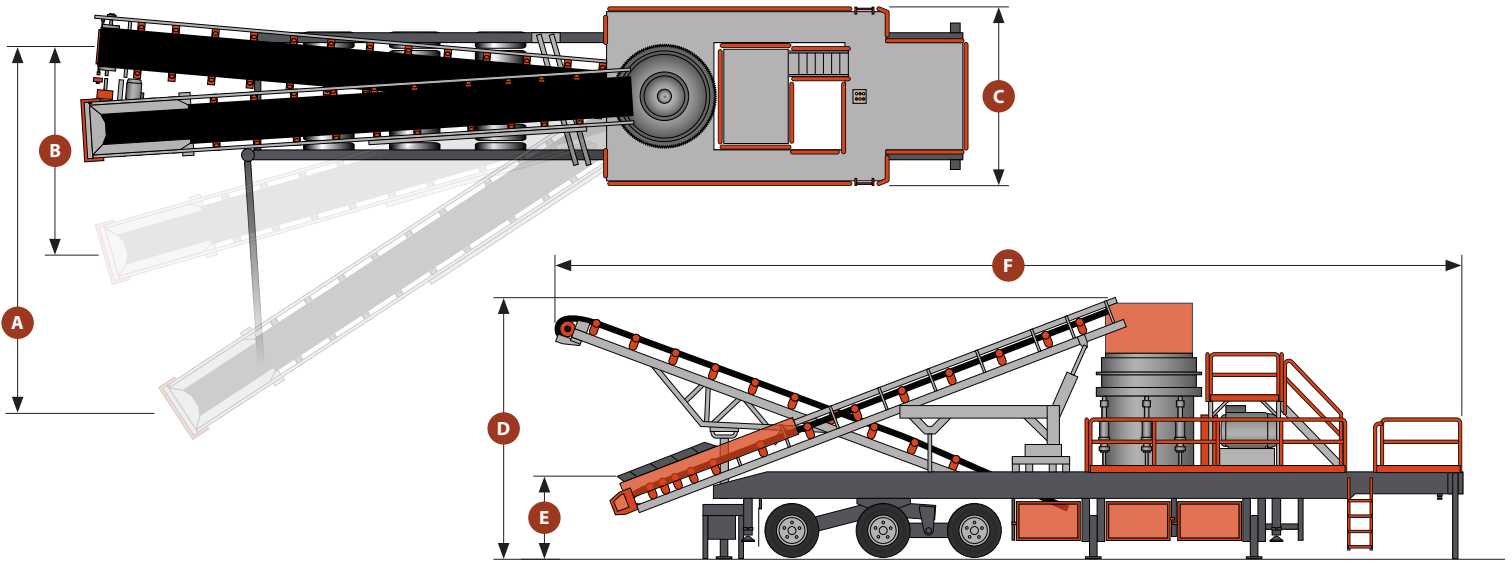

OPERATION DIMENSIONS - INCHES (MM)

	A	B	C	D	E	F
P200	262 (6,655)	131 (3,325)	141 (3,595)	178 (4,520)	69 (1,750)	635 (16,130)
P300	300 (7,625)	134 (3,405)	141 (3,595)	208 (5,285)	67 (1,710)	728 (18,505)
P400	266 (6,770)	134 (3,405)	144 (3,655)	199 (5,055)	68 (1,730)	728 (18,505)

TRANSPORT DIMENSIONS

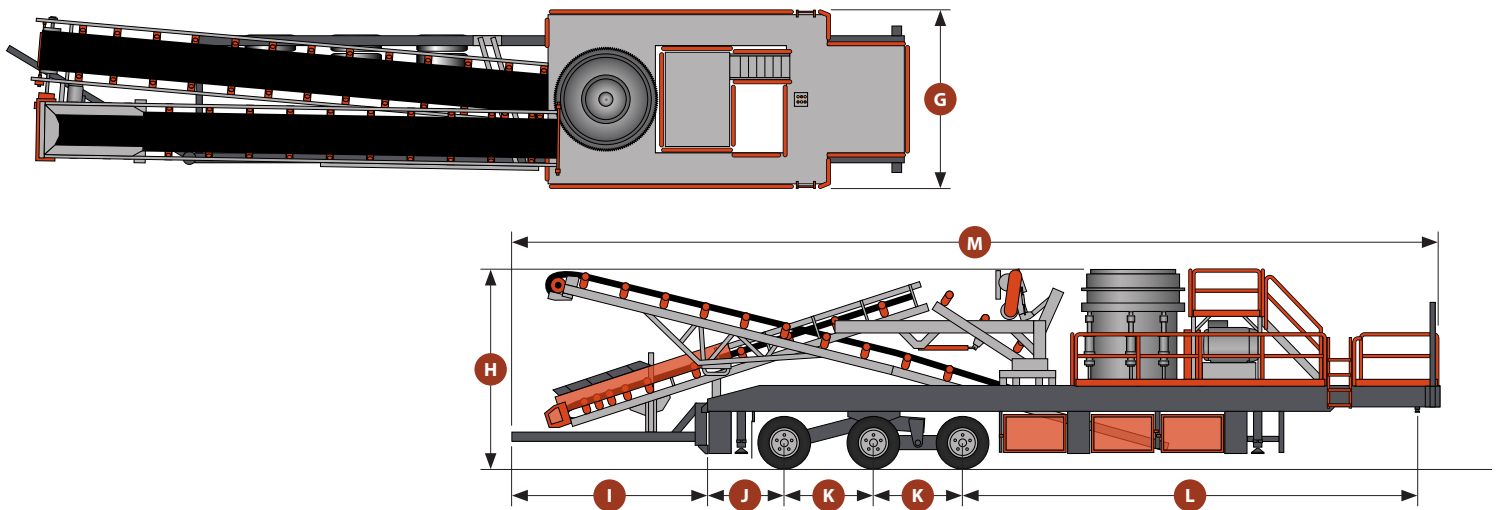

TRAVEL DIMENSIONS - INCHES (MM)

	G	H	I	J	K	L	M
P200	141 (3,595)	159 (4,040)	178 (4,520)	51 (1,295)	49 (1,245)	376 (9,550)	727 (18,465)
P300	141 (3,595)	162 (4,115)	161 (4,095)	62 (1,585)	73 (1,855)	373 (9,475)	761 (19,335)
P400	144 (3,655)	167 (4,255)	137 (3,490)	45 (1,145)	73 (1,855)	397 (10,085)	752 (19,115)