



Equal Troughing Idler

IDLER CATALOG

phone: 1-800-437-9074

website: www.superior-ind.com

315 East State Highway 28
Morris, Minnesota 56267, USA

SPINGUARD® SEAL SYSTEM CUTAWAY

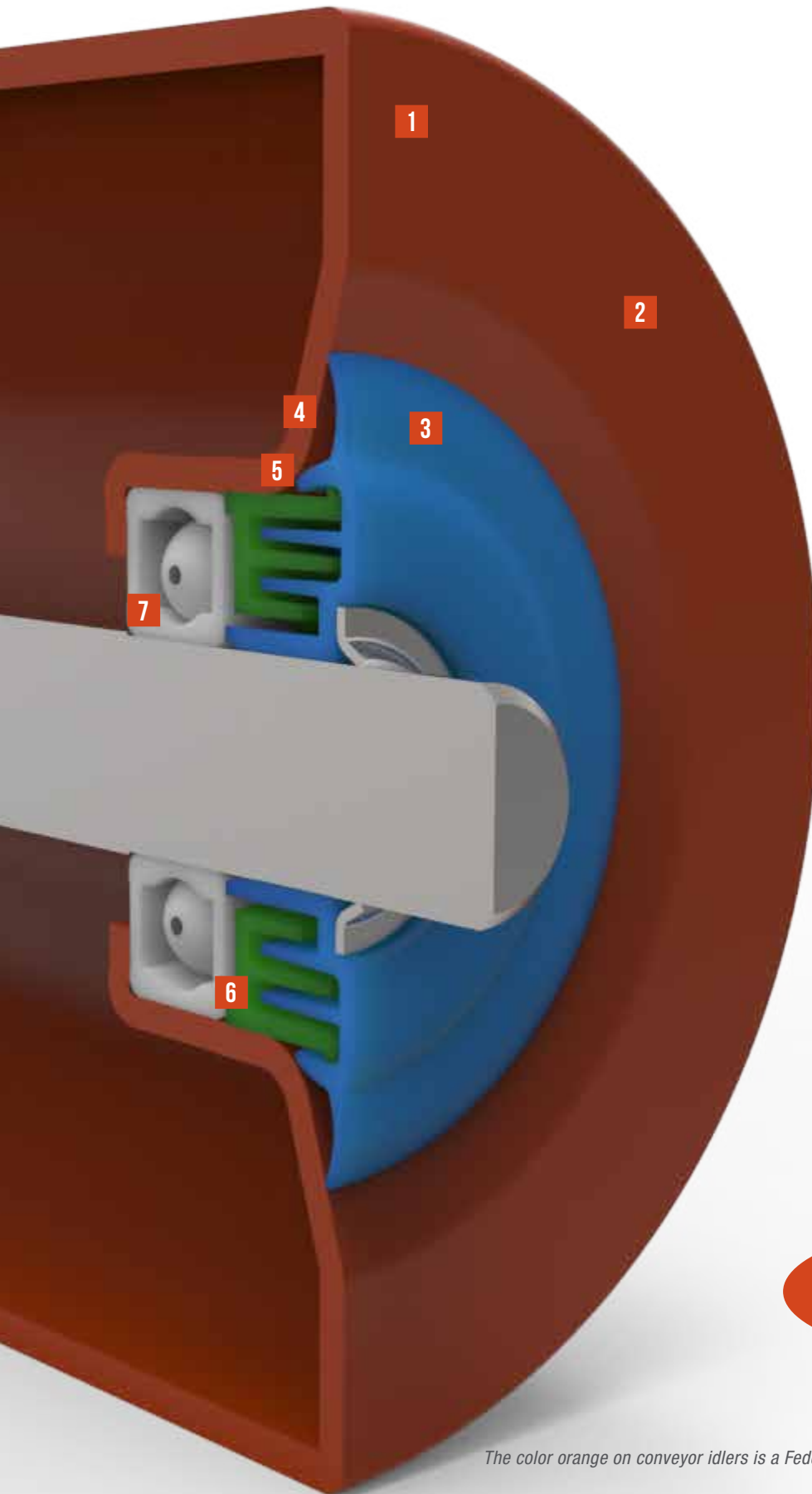

- 1 END DISC**
Tapered end disc allows external seal and end cap to shed material.
- 2 FLAT SURFACE**
Material will not build up across the flat surface.
- 3 STATIONARY EXTERNAL SEAL**
Stationary external seal helps prevent material pinch points between the frame and the end of the roller.
- 4 CENTRIFUGAL FORCE CHAMBER**
Centrifugal force creates a self-cleaning flinger effect, keeping water and dirt out.
- 5 CONTACT SEAL**
- 6 TRIPLE LABYRINTH SEAL**
Second defense is the triple labyrinth seal which makes contaminants travel a longer distance.
 - The labyrinth is also grease filled to keep contaminants away from the ball bearing.
 - The glass filled polypropylene seal material is more durable and is less susceptible to corrosion.
- 7 BALL BEARING**
Factory sealed metric ball bearing on all CEMA rated idlers.



The color orange on conveyor idlers is a Federally Registered trademark of Superior Industries, Inc.

TABLE OF CONTENTS

2	Styles	
3	Ordering Guide	
4	Roll Interchange	
	CEMA B	
5	Troughing Idlers – Equal Length Rollers	
6	Troughing Idlers – Rubber Cushion Impact	
6	Urathon® Return Roll	
7	Return Idlers	
7	Flat Idlers	
7	Return Idlers – Rubber Cushion	
7	Flat Idlers – Rubber Cushion	
8	Troughing Idlers – Self-Aligning	
8	Return Idlers – Self-Aligning	
9	Offset Center Roll Idlers	
10	Channel Mount Idlers	
10	Channel Mount Impact Idlers	
	CEMA C	
11	Troughing Idlers – Equal Length Rollers	
14	Return Idlers	
14	Flat Idlers	
14	Garland Idlers	
15	Troughing Idlers – Rubber Cushion Impact	
18	Return Idlers – Rubber Cushion	
18	Flat Idlers – Rubber Cushion	
18	V-Return Idlers	
19	Urathon® Return Rolls	
19	Troughing Idlers – Self-Aligning	
21	Return Idlers – Self-Aligning	
22	Troughing Idlers – Feeder / Picking	
23	Troughing Idlers – Unequal Length Rolls	
25	Offset Center Roll Idlers	
27	Channel Mount Idlers	
28	Low Profile Standard Mount	
29	Channel Mount Impact Idlers	
	CEMA D	
30	Troughing Idlers – Equal Length Rolls	
31	Return Idlers	
31	Flat Idlers	
31	V-Return Idlers	
32	Troughing Idlers – Rubber Cushion Impact	
33	Return Idlers – Rubber Cushion	
33	Flat Idlers – Rubber Cushion	
33	Urathon® Return Rolls	
34	Troughing Idlers – Self-Aligning	
35	Return Idlers – Self-Aligning	
35	Feeder / Picking Idlers	
36	Troughing Idlers – Unequal Length Rollers	
	CEMA E	
37	Troughing Idlers – Equal Length Rollers	
37	Troughing Idlers – Rubber Cushion Impact	
38	Return Idlers – Rubber Cushion	
39	Troughing Idler – Self-Aligning	
40	Return Idlers	
40	Flat Idlers – Rubber Cushion	
40	Flat Idlers	
40	Return Idlers – Self-Aligning	
41	Urathon® Return Rolls	
41	V-Return Idlers	
	CEMA F	
42	Troughing Idlers – Equal Length Rollers	
	OTHER STYLES	
43	Component Parts & Replacement Rolls	
43	CEMA B & C Replacement Rolls	
44	CEMA D & E Replacement Rolls	
45	81 Series CEMA C Regreaseable Idlers	
58	91 Series CEMA D Regreaseable Idlers	
64	Regreaseable Idler Parts	
65	40 Series	
66	CB504 Series	
66	Component Accessories	
67	Navigator® Training Idlers	
67	Return Guides	
68	80/81 & 90/91 Hex Style Roll Guard	
68	Slotted Shaft Return Guard	
68	Beater Bar Return Roll	
69	Live Shaft Rollers	
69	Side Guide Idlers	
69	Vertical Side Guide Roll	
69	Urethane Vertical Side Guide Roll	
69	Stub Roll Idlers	
70	Variable Pitch Idlers	
70	Wire Rope Pitch	
71	Rubber Lagged Conveyor Rollers	
72	Sealing System	
73	Impact Beds	
74	Return & Flat Bracket Styles	
76	Specialized Designs	
77	Idler Selection Procedure	
81	Terms & Conditions	

BASIC IDLER STYLES



EQUAL TROUGHING IDLERS



IMPACT IDLERS



OFFSET CENTER ROLL IDLERS



CHANNEL MOUNT
LOW PROFILE IDLERS



FEEDER/PICKING IDLERS



UNEQUAL TROUGHING IDLERS



CB504 SERIES IDLERS



GARLAND IDLERS



RETURN BELT IDLERS



RUBBER CUSHION
RETURN IDLERS



URATHON® RETURN ROLL



SPIRAL URATHON®
RETURN ROLL



SELF-ALIGNER IDLERS



SELF-ALIGNER RETURNS



FLAT CARRIER IDLERS



RUBBER CUSHION
FLAT CARRIES



LIVE SHAFT ROLLERS



40 SERIES IDLERS



VARIABLE PITCH IDLERS



V-RETURN IDLERS



WIRE ROPE IDLERS



BEATER BAR

ORDERING GUIDE

Superior makes ordering easy with a simple number and letter system so you can easily jot down the idlers you need and relay them to our sales staff. Superior manufactures many different styles of CEMA B, C, D, E, and F idlers along with a full line of CB-504 style bearing idlers and rollers. We have been in the idler manufacturing business since 1974 and have modified and expanding our product offering to provide solutions for our customers. Simply follow the procedure below and you'll be on your way to placing an accurate order.

C5 - 35 E - 36

1. CEMA Rating

(or Series)- Specify either CEMA B, C, D, E, or F.

2. Roll Diameter

Specify either 4, 5, 6, 7, or 8 for the corresponding roll size diameter.

3. Troughing Angle

Troughing Angle - Specify either 20, 35, or 45 for the corresponding troughing angle.
V-Return - Specify either 10, 15 for the corresponding troughing angle.

4. Idler Type Letter

Specify the idler identification letter for the particular idler you may need from the chart above.

5. Belt Width

Specify the belt width.

- E.....Troughing Idler Equal Length Rolls
- EASelf-Aligning Troughing Idler
- BABi-Directional Aligning Troughing Idler
- EL.....Rubber Cushion Troughing Idler
- GOOffset Troughing Idler
- UTroughing Idler Unequal Length Rolls
- PFeeder / Picking Idler
- RETReturn Idler
- FLTFlat Carrier Idler
- RETAReturn Self-Aligning Idler
- RETIReturn Rubber Cushion Idler
- FLTIFlat Carrier Rubber Cushion Idler
- CMLow-Profile Channel Mount Idler
- CMIChannel Mount Impact Low Profile Idler
- SMLow-Profile Standard Mount Idler
- SMIStandard Mount Impact Low Profile Idler
- RETAL.....Return Self-Aligning Rubber Lagged Cushion Idler
- EWWire Rope Idler
- VPEVariable Pitch Idler
- RETUUrathon® Return
- RETUSP.....Spiral Urathon® Return
- MOXMoxie® Roll (i.e. C5-35E-30MOX)
- LSBLive Shaft Beater (i.e. LSB-530-107)

SHIPPING NOTES

- 4-6 Pulleys fit per pallet depending on size
- CB ROLLS: 2 returns per box or 6 rolls per box for UPS
- Expedite services are available for a minimum of \$50

PALLET LOADS FOR SHIPPING

Returns

ROLLER DIAMETER	PIECES/PALLET
4"	34 max
5"	21 max
6"	18 max

CEMA B Idlers

ROLLER DIAMETER	IDLERS/ROW	NUMBER OF ROWS	PIECES/PALLET
4"	11	2 rows	22 max
5"	9	2 rows	18 max

Hex Brackets

BRACKET	WEIGHT
4-1/2" Drop	3 lb
1 1/2" Drop	2.05 lb
4-1/2" Rise	2.8 lb
1 1/2" Rise	1.25 lb

CEMA C Idlers

ROLLER DIAMETER	IDLERS/ROW	NUMBER OF ROWS	PIECES/PALLET
4"	11	Up to 36" BW = 2 rows	22 max
		42" - 48" BW = 2 rows	18 max
5"	9	Up to 36" BW = 2 rows	18 max
		42" BW = 2 rows	18 max
		48" BW = 2 rows	18 max
		54" BW & Up = 1 row	8 max
6"	7	Up to 30" BW = 2 rows	14 max
		36" BW & Up = 1 row	7 max

Other Products

PRODUCT	PIECES/PALLET
Picking Idlers	Standard
Channel Mounts	20 max
Self Aligners (EA)	2 max
Self Aligners (RETA)	3 max
Bi-Directional	3 max
Off Set Idlers (GO)	7 max

Slotted Brackets

BRACKET	WEIGHT
4-1/2" Drop	1.54 lb
1 1/2" Drop	.84 lb
4-1/2" Rise	2.94 lb
1 1/2" Rise	1.76 lb

Note: Dimensions in entire catalog are subject to change without notice. Certified prints available upon request for construction.

ROLL INTERCHANGE

COMPETITOR RETROFIT

C6-360100

PART NUMBERING

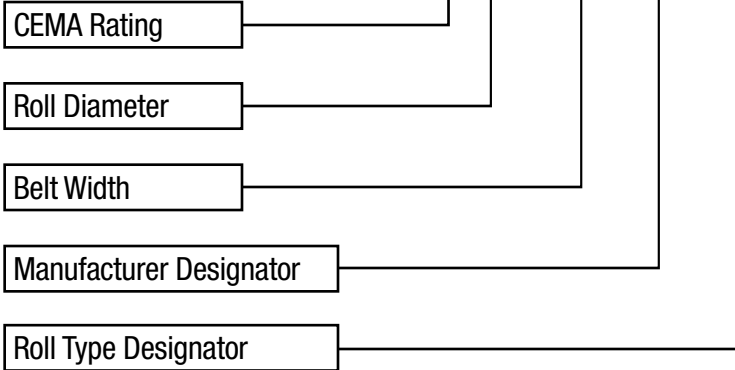

Manufacturer	
01	Precision
02	Continental (HC-slot)
03	Stephens Adamson
04	DBT
05	FMC (slot)
06	Hewitt-Robins (slot)
07	Luff
08	Assink
09	Strongco
10	Douglas (slot)
11	FMC 3000 (nut)
12	Douglas (nut)
13	Rexnord (nut)
14	Hewitt-Robins (nut)
15	Continental (H+-nut)
16	Goodman (nut)

CEMA RATING OR SERIES: Specify either CEMA B, C, D, or E.

ROLL SIZE: Specify either 4, 5, 6 or 7 for the corresponding roll size diameter.

BELT WIDTH: Specify either 18, 24, 30, 36, 42, 48, 54, 60, 72, 84, or 96 depending on or CEMA rating.

MANUFACTURER: Specify the idler manufacturer that you are attempting to fit (see manufacturer's list above).

ROLL TYPE: Specify the type of roll you are attempting to fit, steel trough (00), steel return (01), troughing impact (03), or return impact (11).

	EXAMPLE	ROLL 1
Shaft Type (slot/nut)	Slot	
Roll Diameter (RD)	5	
Roll Length (RL)	11.0625	
Frame Fit (FF)	11.30	
Slot-to-Slot (BB)	11.85	
Across Slot (AB)	.545	
Shaft Diameter (SD)	20mm	
Shaft Length (SL)	12.3125	
Through Shaft Diameter (TS)	20mm	
Hex Nut Outside-to-Outside (OO)	-	

RETRO FIT ROLL DIMENSIONS

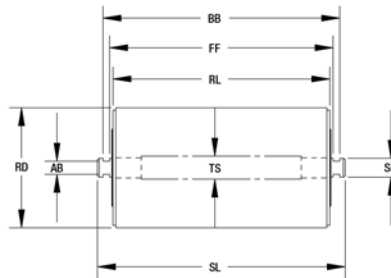

SLOTTED SHAFT END

ROLLER

SLOT OR HEX NUT DIMENSIONS	EXAMPLE	ROLL 1
A	20mm	
B	.545	
C	.231	
D	.275	
E	-	

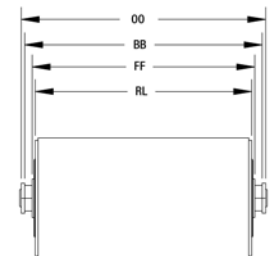
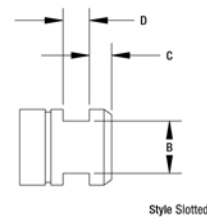

HEX NUT END

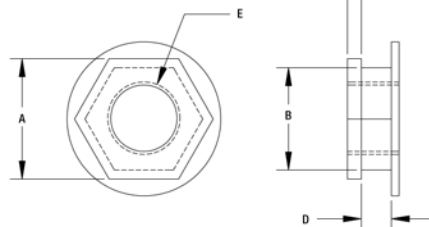

CEMA B IDLERS

TROUGHING IDLERS (EQUAL LENGTH ROLLERS) – 4" & 5" DIAMETER

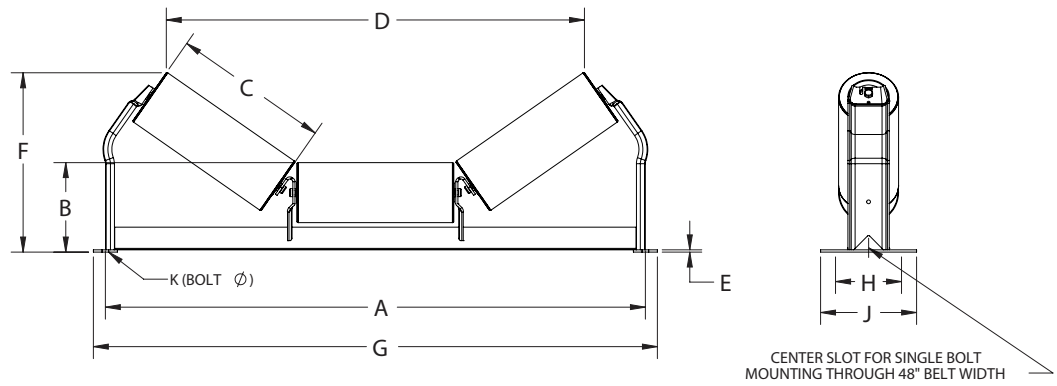

CEMA B

	PART NUMBER*		BW	A	B		C	D		E	F		G	H**	J	K	WT (#)	
	4"	5"			4"	5"		4"	5"		4"	5"					4"	5"
20°	B4-20E-14	B5-20E-14	14	23	6-15/16	7-7/16	6-1/16	18-15/16	18-9/16	3/16	9-1/8	9-9/16	25	6	8	1/2	25	30
	B4-20E-16	B5-20E-16	16	25	6-15/16	7-7/16	6-1/16	18-15/16	18-9/16	3/16	9-1/8	9-5/8	27	6	8	1/2	25	30
	B4-20E-18	B5-20E-18	18	27	6-15/16	7-7/16	7-1/16	21-3/4	21-7/16	3/16	9-7/16	9-7/8	29	6	8	1/2	27	33
	B4-20E-20	B5-20E-20	20	29	6-15/16	7-7/16	7-11/16	23-13/16	23-1/2	3/16	9-7/16	9-15/16	31	6	8	1/2	29	35
	B4-20E-24	B5-20E-24	24	33	6-15/16	7-7/16	9-1/16	27-1/2	27-3/16	3/16	10-1/8	10-9/16	35	6	8	1/2	32	39
	B4-20E-30	B5-20E-30	30	39	6-15/16	7-7/16	11-1/16	33-5/16	32-15/16	3/16	10-13/16	11-5/16	41	6	8	1/2	40	49
	B4-20E-36	B5-20E-36	36	45	6-15/16	7-7/16	13-1/16	39-1/16	38-11/16	3/16	11-1/2	12	47	6	8	1/2	46	56
	B4-20E-42	B5-20E-42	42	51	7-7/16	7-15/16	15-1/16	44-13/16	44-7/16	5/16	12-11/16	13-3/16	53	7-1/2	9-1/2	5/8	61	72
B4-20E-48	B5-20E-48	48	57	7-7/16	7-15/16	17-1/16	50-9/16	50-3/16	5/16	13-3/8	13-7/8	59	7-1/2	9-1/2	5/8	67	80	
35°	B4-35E-14	B5-35E-14	14	23	6-15/16	7-7/16	6-1/16	16-15/16	16-3/8	3/16	10-1/2	10-7/8	25	6	8	1/2	26	31
	B4-35E-16	B5-35E-16	16	25	6-15/16	7-7/16	6-1/16	16-15/16	16-3/8	3/16	10-1/2	10-7/8	27	6	8	1/2	26	31
	B4-35E-18	B5-35E-18	18	27	6-15/16	7-7/16	7-1/16	19-5/8	19	3/16	11-1/16	11-7/16	29	6	8	1/2	28	34
	B4-35E-20	B5-35E-20	20	29	6-15/16	7-7/16	7-11/16	21-13/16	21-5/16	3/16	11-1/8	11-9/16	31	6	8	1/2	30	36
	B4-35E-24	B5-35E-24	24	33	6-15/16	7-7/16	9-1/16	24-7/8	24-5/16	3/16	12-3/16	12-5/8	35	6	8	1/2	33	41
	B4-35E-30	B5-35E-30	30	39	6-15/16	7-7/16	11-1/16	30-3/16	29-9/16	3/16	13-3/8	13-13/16	41	6	8	1/2	42	50
	B4-35E-36	B5-35E-36	36	45	6-15/16	7-7/16	13-1/16	35-7/16	34-7/8	3/16	14-9/16	14-15/16	47	6	8	1/2	47	57
	B4-35E-42	B5-35E-42	42	51	7-7/16	7-15/16	15-1/16	40-11/16	40-1/8	5/16	16-3/16	16-9/16	53	7-1/2	9-1/2	5/8	62	74
B4-35E-48	B5-35E-48	48	57	7-7/16	7-15/16	17-1/16	46	45-3/8	5/16	17-5/16	17-3/4	59	7-1/2	9-1/2	5/8	69	82	
45°	B4-45E-18	B5-45E-18	18	27	6-15/16	7-7/16	7-1/16	18-3/16	17-1/2	3/16	11-7/8	12-1/4	29	6	8	1/2	29	35
	B4-45E-24	B5-45E-24	24	33	6-15/16	7-7/16	9-1/16	23	22-1/4	3/16	13-5/16	13-5/8	35	6	8	1/2	34	41
	B4-45E-30	B5-45E-30	30	39	6-15/16	7-7/16	11-1/16	27-13/16	27-1/8	3/16	14-3/4	15-1/8	41	6	8	1/2	42	51
	B4-45E-36	B5-45E-36	36	45	6-15/16	7-7/16	13-1/16	32-5/8	31-15/16	3/16	16-3/16	16-1/2	47	6	8	1/2	48	58
	B4-45E-42	B5-45E-42	42	51	7-7/16	7-15/16	15-1/16	37-1/2	36-3/4	5/16	18-1/8	18-7/16	53	7-1/2	9-1/2	5/8	63	75
	B4-45E-48	B5-45E-48	48	57	7-7/16	7-15/16	17-1/16	42-5/16	41-9/16	5/16	19-1/2	19-7/8	59	7-1/2	9-1/2	5/8	70	83

*Add MOX to the end of the part number to replace steel cans with Moxie Rolls

**Recommended Bolt Pattern - See page 75 for minimum and maximum dimensions.

CEMA B IDLERS

RUBBER CUSHION IMPACT TROUGHING IDLERS – 4" & 5" DIAMETER

CEMA B

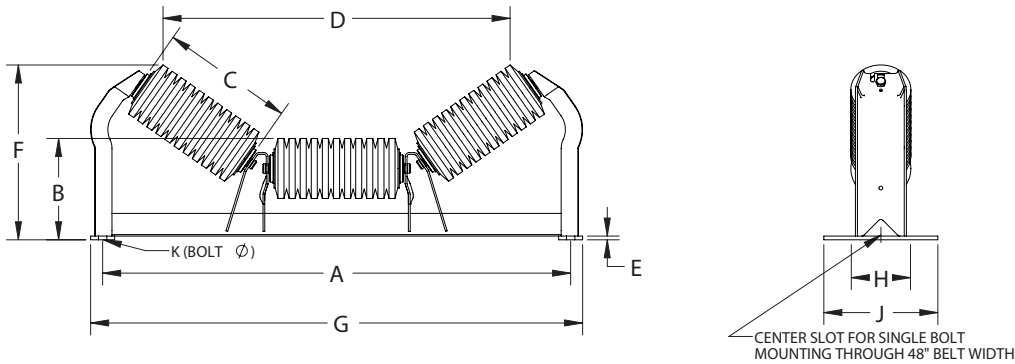

PART NUMBER		BW*	A	B		C	D		E	F		G	H**	J	K	WT (#)	
4"	5"			4"	5"		4"	5"		4"	5"					4"	5"
B4-20EI-18	B5-20EI-18	18	27	6-15/16	7-7/16	7-1/8	20-1/2	20-3/16	3/16	9-1/4	9-3/4	29	6	8	1/2	31	36
B4-20EI-24	B5-20EI-24	24	33	6-15/16	7-7/16	9-1/8	26-1/4	25-15/16	3/16	9-15/16	10-3/8	35	6	8	1/2	38	43
B4-20EI-30	B5-20EI-30	30	39	6-15/16	7-7/16	11-1/8	32	31-3/4	3/16	10-5/8	11-1/8	41	6	8	1/2	47	54
B4-20EI-36	B5-20EI-36	36	45	6-15/16	7-7/16	13-1/8	37-3/4	37-1/2	3/16	11-5/16	11-13/16	47	6	8	1/2	63	72
B4-20EI-42	B5-20EI-42	42	51	7-7/16	7-15/16	15-1/8	43-9/16	43-1/4	5/16	12-1/2	13	53	7-1/2	9-1/2	1/2	80	90
B4-20EI-48	B5-20EI-48	48	57	7-7/16	7-15/16	17-1/8	49-5/16	49	5/16	13-3/16	13-11/16	59	7-1/2	9-1/2	5/8	88	99
B4-35EI-18	B5-35EI-18	18	27	6-15/16	7-7/16	7-1/8	18-7/16	17-15/16	3/16	10-3/4	11-3/16	29	6	8	1/2	32	36
B4-35EI-24	B5-35EI-24	24	33	6-15/16	7-7/16	9-1/8	23-11/16	23-3/16	3/16	11-7/8	12-5/16	35	6	8	1/2	39	44
B4-35EI-30	B5-35EI-30	30	39	6-15/16	7-7/16	11-1/8	29	28-7/16	3/16	13-1/16	13-1/2	41	6	8	1/2	48	55
B4-35EI-36	B5-35EI-36	36	45	6-15/16	7-7/16	13-1/8	34-3/16	33-11/16	3/16	14-1/4	14-11/16	47	6	8	1/2	66	74
B4-35EI-42	B5-35EI-42	42	51	7-7/16	7-15/16	15-1/8	39-1/2	38-15/16	5/16	15-15/16	16-5/16	53	7-1/2	9-1/2	5/8	83	92
B4-35EI-48	B5-35EI-48	48	57	7-7/16	7-15/16	17-1/8	44-3/4	44-1/4	5/16	17-1/16	17-1/2	59	7-1/2	9-1/2	5/8	91	102
B4-45EI-18	B5-45EI-18	18	27	6-15/16	7-7/16	7-1/8	17-1/8	16-1/2	3/16	11-1/2	11-7/8	29	6	8	1/2	34	37
B4-45EI-24	B5-45EI-24	24	33	6-15/16	7-7/16	9-1/8	25-15/16	21-5/16	3/16	12-7/8	13-3/16	35	6	8	1/2	39	45
B4-45EI-30	B5-45EI-30	30	39	6-15/16	7-7/16	11-1/8	26-13/16	26-1/8	3/16	14-5/16	14-11/16	41	6	8	1/2	49	56
B4-45EI-36	B5-45EI-36	36	45	6-15/16	7-7/16	13-1/8	31-1/2	30-13/16	3/16	15-13/16	16-13/16	47	6	8	1/2	68	76
B4-45EI-42	B5-45EI-42	42	51	7-7/16	7-15/16	15-1/8	37-7/16	35-3/4	5/16	17-11/16	18-1/16	53	7-1/2	9-1/2	5/8	85	94
B4-45EI-48	B5-45EI-48	48	57	7-7/16	7-15/16	17-1/8	41-1/2	40-9/16	5/16	19-1/16	19-1/2	59	7-1/2	9-1/2	5/8	93	104

20°

35°

45°

URATHON® RETURN ROLL – 5" DIAMETER

5" PART NUMBERS	BW	A	B	C	WT***
B5-RETU-18	18	27	21-3/8	28-7/16	21
B5-RETU-24	24	33	27-3/8	34-7/16	24
B5-RETU-30	30	39	33-3/8	40-7/16	28
B5-RETU-36	36	45	39-3/8	46-7/16	32
B5-RETU-42	42	51	45-3/8	52-7/16	36
B5-RETU-48	48	57	51-3/8	58-7/16	40

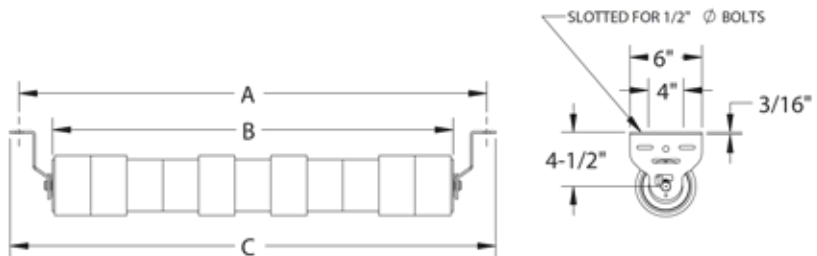

Note: Spiral Urathon is only available in 6" diameter.

* Belt Width (Reinforcing on 36" BW - 48" BW Impact Frame.)

** Recommended Bolt Pattern - See page 75 for minimum and maximum dimensions.

***All weights include brackets, individual bracket weights are listed on page 74 and 75. Brackets sold separately.

CEMA B IDLERS

RETURN IDLERS – 4" & 5" DIAMETER

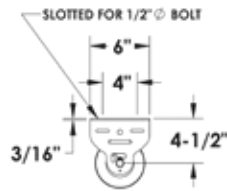
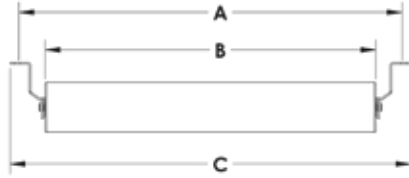

PART NUMBER		BW	A	B	C	WT (#)*	
4"	5"					4"	5"
B4-RET-14	B5-RET-14	14	23	17-3/8	24-7/16	14	18
B4-RET-16	B5-RET-16	16	25	19-3/8	26-7/16	15	20
B4-RET-18	B5-RET-18	18	27	21-3/8	28-7/16	16	21
B4-RET-20	B5-RET-20	20	29	23-3/8	30-7/16	17	23
B4-RET-24	B5-RET-24	24	33	27-3/8	34-7/16	19	26
B4-RET-30	B5-RET-30	30	39	33-3/8	40-7/16	22	30
B4-RET-36	B5-RET-36	36	45	39-3/8	46-7/16	25	35
B4-RET-42	B5-RET-42	42	51	45-3/8	52-7/16	29	39
B4-RET-48	B5-RET-48	48	57	51-3/8	58-7/16	32	44

FLAT IDLERS – 4" & 5" DIAMETER

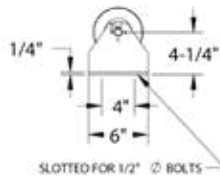
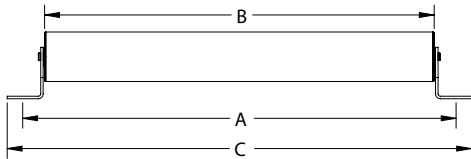

PART NUMBER		BW	A	B	C	WT (#)*	
4"	5"					4"	5"
B4-FLT-14	B5-FLT-14	14	23	17-3/8	24-15/16	16	21
B4-FLT-16	B5-FLT-16	16	25	19-3/8	26-15/16	18	22
B4-FLT-18	B5-FLT-18	18	27	21-3/4	28-15/16	19	24
B4-FLT-20	B5-FLT-20	20	29	23-3/8	30-15/16	20	25
B4-FLT-24	B5-FLT-24	24	33	27-3/8	34-15/16	22	28
B4-FLT-30	B5-FLT-30	30	39	33-3/8	40-15/16	25	33
B4-FLT-36	B5-FLT-36	36	45	39-3/8	46-15/16	28	37
B4-FLT-42	B5-FLT-42	42	51	45-3/8	52-15/16	31	42
B4-FLT-48	B5-FLT-48	48	57	51-3/8	58-15/16	34	46

RUBBER CUSHION RETURN IDLERS – 4" & 5"

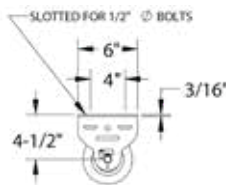
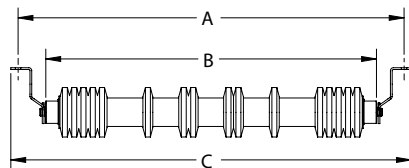

PART NUMBER		BW	A	B	C	WT (#)*	
4"	5"					4"	5"
B4-RETI-18	B5-RETI-18	18	27	21-7/16	28-7/16	19	21
B4-RETI-20	B5-RETI-20	20	29	23-7/16	30-7/16	20	23
B4-RETI-24	B5-RETI-24	24	33	27-7/16	34-7/16	23	26
B4-RETI-30	B5-RETI-30	30	39	33-7/16	40-7/16	26	30
B4-RETI-36	B5-RETI-36	36	45	39-7/16	46-7/16	30	34
B4-RETI-42	B5-RETI-42	42	51	45-7/16	52-7/16	34	38
B4-RETI-48	B5-RETI-48	48	57	51-7/16	58-7/16	37	41

RUBBER CUSHION FLAT IDLERS – 4" & 5"

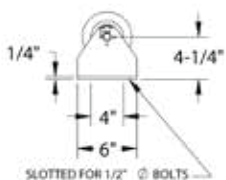
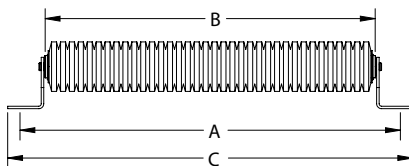

PART NUMBER		BW	A	B	C	WT (#)*	
4"	5"					4"	5"
B4-FLTI-18	B5-FLTI-18	18	27	21-7/16	28-15/16	23	28
B4-FLTI-24	B5-FLTI-24	24	33	27-7/16	34-15/16	28	34
B4-FLTI-30	B5-FLTI-30	30	39	33-7/16	40-15/16	33	40
B4-FLTI-36	B5-FLTI-36	36	45	39-7/16	46-15/16	37	46
B4-FLTI-42	B5-FLTI-42	42	51	45-7/16	52-15/16	42	52
B4-FLTI-48	B5-FLTI-48	48	57	51-7/16	58-15/16	47	59

* All weights include brackets, individual bracket weights are listed on page 74 and 75. Brackets sold separately.

CEMA B IDLERS

SELF-ALIGNING TROUGHING IDLERS – 4" & 5"

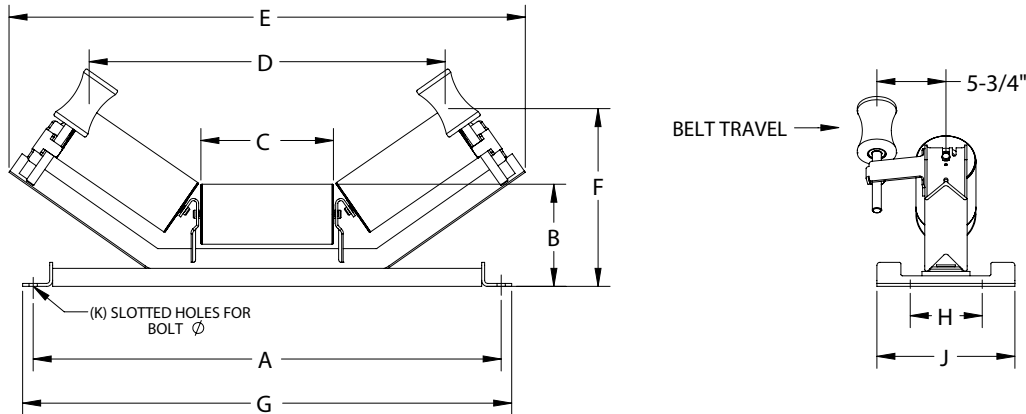

PART NUMBER		BW	A	B		C	D		E	F		G	H	J	K	WT (#)	
4"	5"			4"	5"		4"	5"		4"	5"					4"	5"
B4-20EA-18	B5-20EA-18	18	27	8	8-1/2	7-1/16	21-3/4	21-7/16	30 5/8	10-1/2	10-15/16	28-3/4	6	11-1/2	5/8	73	80
B4-20EA-24	B5-20EA-24	24	33	8	8-1/2	9-1/16	27-9/16	27-3/16	36-3/8	11-3/16	11-5/8	34-3/4	6	11-1/2	5/8	82	90
B4-20EA-30	B5-20EA-30	30	39	8	8-1/2	11-1/16	33-5/16	33	42-3/16	11-7/8	12-3/8	40-3/4	6	11-1/2	5/8	95	103
B4-20EA-36	B5-20EA-36	36	45	8	8-1/2	13-1/16	39-1/16	38-11/16	47-15/16	12-9/16	13-1/16	46-3/4	6	11-1/2	5/8	103	113
B4-20EA-42	B5-20EA-42	42	51	8-3/8	8-7/8	15-1/16	44-13/16	44-1/2	54	13-5/8	14-1/8	52-3/4	6	11-1/2	5/8	113	134
B4-20EA-48	B5-20EA-48	48	57	8-3/8	8-7/8	17-1/16	50-9/16	50-1/4	59-3/4	14-5/16	14-13/16	58-3/4	6	11-1/2	5/8	123	145
B4-35EA-18	B5-35EA-18	18	27	8	8-1/2	7-1/16	19-11/16	19-3/16	32-7/16	12-1/16	12-1/2	28-3/4	6	11-1/2	5/8	75	80
B4-35EA-24	B5-35EA-24	24	33	8	8-1/2	9-1/16	24-15/16	24-7/16	37-11/16	13-1/4	13-5/8	34-3/4	6	11-1/2	5/8	84	91
B4-35EA-30	B5-35EA-30	30	39	8	8-1/2	11-1/16	30-1/4	29-11/16	43	14-3/8	14-13/16	40-3/4	6	11-1/2	5/8	96	105
B4-35EA-36	B5-35EA-36	36	45	8	8-1/2	13-1/16	35-1/2	34-15/16	48-5/16	15-9/16	15-15/16	46-3/4	6	11-1/2	5/8	105	115
B4-35EA-42	B5-35EA-42	42	51	8-3/8	8-7/8	15-1/16	40-13/16	40-3/16	54	17-1/16	17-1/2	52-3/4	6	11-1/2	5/8	125	136
B4-35EA-48	B5-35EA-48	48	57	8-3/8	8-7/8	17-1/16	46-1/16	45-1/2	59-5/16	18-1/4	18-5/8	58-3/4	6	11-1/2	5/8	135	148
B4-45EA-18	B5-45EA-18	18	27	8	8-1/2	7-1/16	17-15/16	17-1/4	31	12-15/16	13-5/16	28-3/4	6	11-1/2	5/8	75	81
B4-45EA-24	B5-45EA-24	24	33	8	8-1/2	9-1/16	22-13/16	22-1/8	34-7/16	14-3/8	14-11/16	34-3/4	6	11-1/2	5/8	84	91
B4-45EA-30	B5-45EA-30	30	39	8	8-1/2	11-1/16	27-13/16	27-3/16	40-15/16	15-3/4	16-1/16	40-3/4	6	11-1/2	5/8	97	105
B4-45EA-36	B5-45EA-36	36	45	8	8-1/2	13-1/16	32-11/16	32	45-13/16	17-1/8	17-1/2	46-3/4	6	11-1/2	5/8	105	115
B4-45EA-42	B5-45EA-42	42	51	8-3/8	8-7/8	15-1/16	40-3/4	40-1/8	54-3/16	17-1/2	17-7/8	52-3/4	6	11-1/2	5/8	126	137
B4-45EA-48	B5-45EA-48	48	57	8-3/8	8-7/8	17-1/16	45-3/4	45-1/8	59-3/16	18-13/16	19-3/16	58-3/4	6	11-1/2	5/8	137	149

20°

35°

45°

SELF-ALIGNING RETURN IDLERS – 4" & 5" DIAMETER

PART NUMBER		BW	A	B	C	D	WT (#)*	
4"	5"						4"	5"
B4-RETA-18	B5-RETA-18	18	27	21-3/8	29-1/2	25-5/8	62	68
B4-RETA-24	B5-RETA-24	24	33	27-3/8	35-1/2	31-5/8	70	77
B4-RETA-30	B5-RETA-30	30	39	33-3/8	41-1/2	37-5/8	80	88
B4-RETA-36	B5-RETA-36	36	45	39-3/8	47-1/2	43-5/8	88	97
B4-RETA-42	B5-RETA-42	42	51	45-3/8	53-1/2	49-5/8	104	115
B4-RETA-48	B5-RETA-48	48	57	51-3/8	59-1/2	55-5/8	113	125

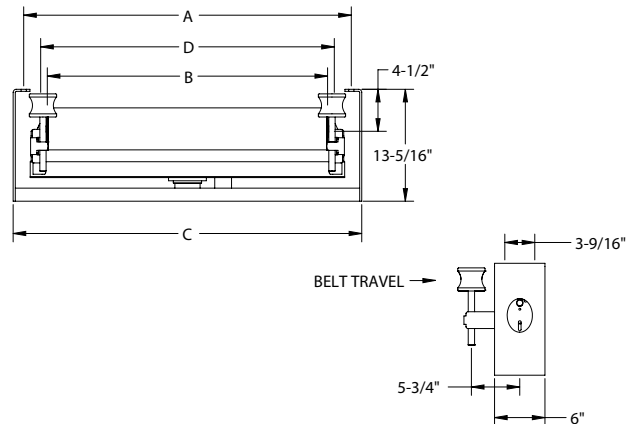

Bigfoot bolting pattern and lagged roller option available

NOTE: Also available in Bi-Directional. Designated by (BA).

* All weights include brackets only applies to RET, RETI, FLT or FLTI.

Individual bracket weights are listed on page 74 and 75. Brackets sold separately.

CEMA B IDLERS

OFFSET CENTER ROLL IDLERS – 4" & 5" DIAMETER

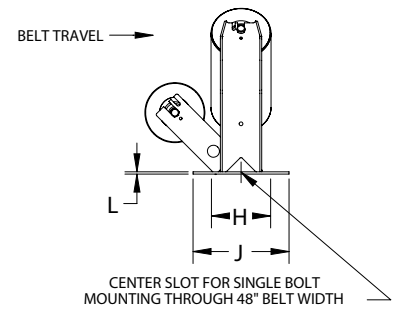
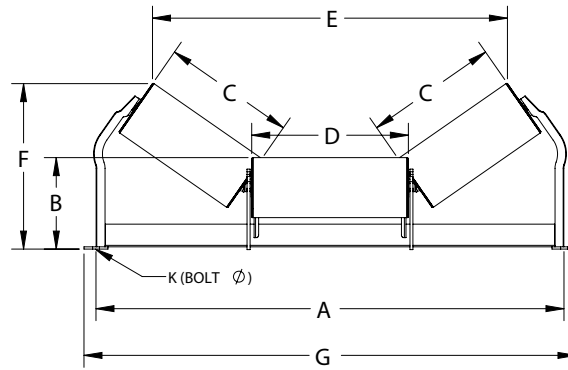

	PART NUMBER		BW	A	B		C	D	E		F		G	H*	J	K	L	WT (#)	
	4"	5"			4"	5"			4"	5"	4"	5"						4"	5"
20°	B4-20GO-18	B5-20GO-18	18	27	7-3/16	7-11/16	7-1/16	9-1/16	21-11/16	21-7/16	9-3/8	9-7/8	29	6	8	1/2	3/16	31	37
	B4-20GO-24	B5-20GO-24	24	33	7-3/16	7-11/16	9-1/16	11-1/16	27-7/16	27-3/16	10-1/16	10-9/16	35	6	8	1/2	3/16	36	43
	B4-20GO-30	B5-20GO-30	30	39	7-3/16	7-11/16	11-1/16	13-1/16	33-3/16	32-15/16	10-13/16	11-5/16	41	6	8	1/2	3/16	43	52
	B4-20GO-36	B5-20GO-36	36	45	7-3/16	7-11/16	13-1/16	15-1/16	39	38-11/16	11-1/2	12	47	6	9-1/2	1/2	5/16	49	59
	B4-20GO-42	B5-20GO-42	42	51	7-11/16	8-3/16	15-1/16	17-1/16	44-3/4	44-7/16	12-11/16	13-3/16	53	6	9-1/2	5/8	5/16	64	76
	B4-20GO-48	B5-20GO-48	48	57	7-11/16	8-3/16	17-1/16	19-1/16	50-1/2	50-3/16	13-3/8	13-7/8	59	6	9-1/2	5/8	5/16	70	84
35°	B4-35GO-18	B5-35GO-18	18	27	7-1/16	7-9/16	7-1/16	9-1/16	19-5/8	19	11-1/16	11-7/16	29	6	8	1/2	3/16	32	38
	B4-35GO-24	B5-35GO-24	24	33	7-1/16	7-9/16	9-1/16	11-1/16	24-7/8	24-5/16	12-3/16	12-5/8	35	6	8	1/2	3/16	37	44
	B4-35GO-30	B5-35GO-30	30	39	7-1/8	7-5/8	11-1/16	13-1/16	30-3/16	29-9/16	13-3/16	13-13/16	41	6	8	1/2	3/16	45	54
	B4-35GO-36	B5-35GO-36	36	45	7-1/8	7-5/8	13-1/16	15-1/16	35-7/16	34-7/8	14-9/16	14-15/16	47	6	9-1/2	1/2	5/16	50	61
	B4-35GO-42	B5-35GO-42	42	51	7-5/8	8-1/8	15-1/16	17-1/16	40-11/16	40-1/8	16-3/16	16-9/16	53	6	9-1/2	5/8	5/16	66	78
	B4-35GO-48	B5-35GO-48	48	57	7-5/8	8-1/8	17-1/16	19-1/16	46	45-3/8	17-5/16	17-3/4	59	6	9-1/2	5/8	5/16	72	86
45°	B4-45GO-18	B5-45GO-18	18	27	7-1/4	7-3/4	7-1/16	9-1/16	18-3/16	17-7/16	11-7/8	12-1/4	29	6	8	1/2	3/16	32	38
	B4-45GO-24	B5-45GO-24	24	33	7-1/4	7-3/4	9-1/16	11-1/16	23	22-1/4	13-5/16	13-5/8	35	6	8	1/2	3/16	37	45
	B4-45GO-30	B5-45GO-30	30	39	7-5/16	7-13/16	11-1/16	13-1/16	27-13/16	27-1/8	14-3/4	15-1/8	41	6	8	1/2	3/16	46	55
	B4-45GO-36	B5-45GO-36	36	45	7-5/16	7-13/16	13-1/16	15-1/16	32-5/8	31-15/16	16-3/16	16-1/2	47	6	9-1/2	1/2	5/16	51	62
	B4-45GO-42	B5-45GO-42	42	51	7-7/16	7-15/16	15-1/16	17-1/16	37-1/2	36-3/4	18-1/16	18-7/16	53	6	9-1/2	5/8	5/16	67	79
	B4-45GO-48	B5-45GO-48	48	57	7-7/16	7-15/16	17-1/16	19-3/8	42-5/16	41-9/16	19-1/2	19-15/16	59	6	9-1/2	5/8	5/16	74	87

* Recommended Bolt Pattern - See page 75 for minimum and maximum dimensions.

CEMA B IDLERS

CHANNEL MOUNT – 4" & 5" DIAMETER

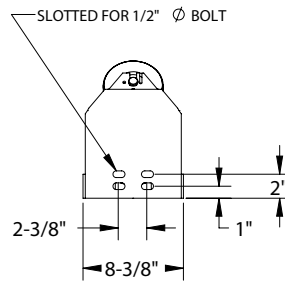
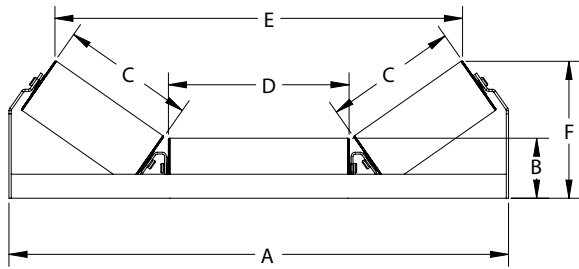

PART NUMBER		BW	A	B		C	D	E		F		WT (#)	
4"	5"			4"	5"			4"	5"	4"	5"	4"	5"
B4-20CM-18	B5-20CM-18	18	23-5/8	4-7/16	4-15/16	6-1/16	7-1/16	20-5/16	19-15/16	6-5/8	7-1/8	30	35
B4-20CM-24	B5-20CM-24	24	29-5/8	4-7/16	4-15/16	7-1/16	11-1/16	26-3/16	25-13/16	7	7-7/16	36	43
B4-20CM-30	B5-20CM-30	30	35-5/8	4-7/16	4-15/16	9-1/16	13-1/16	31-15/16	31-9/16	7-11/16	8-1/8	42	50
B4-20CM-36	B5-20CM-36	36	41-5/8	4-7/16	4-15/16	11-1/16	15-1/16	37-11/16	37-5/16	8-5/16	8-13/16	49	62
B4-20CM-42	B5-20CM-42	42	47-5/8	4-7/16	4-15/16	13-1/16	17-1/16	43-7/16	43-1/16	9	9-1/2	55	66
B4-20CM-48	B5-20CM-48	48	53-5/8	4-7/16	4-15/16	15-1/16	19-1/16	49-3/16	48-13/16	9-11/16	10-3/16	60	73
B4-35CM-18	B5-35CM-18	18	23-5/8	4-7/16	4-15/16	6-1/16	7-1/16	18-7/16	17-13/16	8-1/8	8-1/2	35	41
B4-35CM-24	B5-35CM-24	24	29-5/8	4-7/16	4-15/16	7-1/16	11-1/16	24-1/16	23-1/2	8-11/16	9-1/16	41	48
B4-35CM-30	B5-35CM-30	30	35-5/8	4-7/16	4-15/16	9-1/16	13-1/16	29-5/16	28-3/4	9-13/16	10-1/4	48	56
B4-35CM-36	B5-35CM-36	36	41-5/8	4-7/16	4-15/16	11-1/16	15-1/16	34-5/8	34	10-15/16	11-3/8	55	64
B4-35CM-42	B5-35CM-42	42	47-5/8	4-7/16	4-15/16	13-1/16	17-1/16	39-7/8	39-5/16	12-1/8	12-1/2	62	72
B4-35CM-48	B5-35CM-48	48	53-5/8	4-7/16	4-15/16	15-1/16	19-1/16	45-3/16	44-9/16	13-1/4	13-11/16	86	81

20°

35°

Note: Also available in standard mount designated by SM.

CHANNEL MOUNT IMPACT IDLERS – 4" & 5" DIAMETER

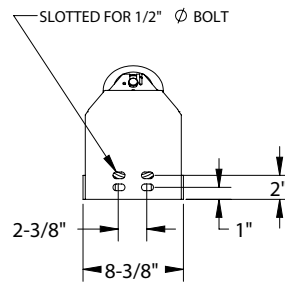
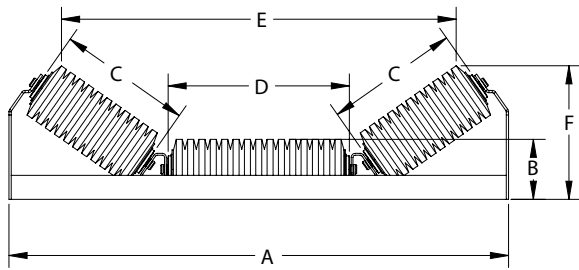

PART NUMBER		BW	A	B		C	D	E		F		WT (#)	
4"	5"			4"	5"			4"	5"	4"	5"	4"	5"
B4-20CMI-18	B5-20CMI-18	18	23-5/8	4-7/16	4-15/16	6-1/8	7-1/8	19	18-11/16	6-7/16	6-15/16	32	36
B4-20CMI-24	B5-20CMI-24	24	29-5/8	4-7/16	4-15/16	7-1/8	11-1/8	24-15/16	24-9/16	6-13/16	7-1/4	40	45
B4-20CMI-30	B5-20CMI-30	30	35-5/8	4-7/16	4-15/16	9-1/8	13-1/8	30-11/16	30-5/16	7-1/2	7-15/16	48	54
B4-20CMI-36	B5-20CMI-36	36	41-5/8	4-7/16	4-15/16	11-1/8	15-1/8	36-7/16	36-1/16	8-3/16	8-5/8	55	63
B4-20CMI-42	B5-20CMI-42	42	47-5/8	4-7/16	4-15/16	13-1/8	17-1/8	42-3/16	41-7/8	8-7/8	9-5/16	63	72
B4-20CMI-48	B5-20CMI-48	48	53-5/8	4-7/16	4-15/16	15-1/8	19-1/8	47-15/16	48-3/16	9-9/16	10	71	81
B4-35CMI-18	B5-35CMI-18	18	23-5/8	4-7/16	4-15/16	6-1/8	7-1/8	17-5/16	16-3/4	7-13/16	8-3/16	37	41
B4-35CMI-24	B5-35CMI-24	24	29-5/8	4-7/16	4-15/16	7-1/8	11-1/8	22-15/16	22-3/8	8-3/8	8-3/4	48	50
B4-35CMI-30	B5-35CMI-30	30	35-5/8	4-7/16	4-15/16	9-1/8	13-1/8	28-3/16	28-3/8	9-1/2	9-7/8	54	60
B4-35CMI-36	B5-35CMI-36	36	41-5/8	4-7/16	4-15/16	11-1/8	15-1/8	33-1/2	35-13/16	10-11/16	11-1/16	62	69
B4-35CMI-42	B5-35CMI-42	42	47-5/8	4-7/16	4-15/16	13-1/8	17-1/8	38-3/4	38-3/16	11-13/16	15-1/4	70	79
B4-35CMI-48	B5-35CMI-48	48	53-5/8	4-7/16	4-15/16	15-1/8	19-1/8	44-1/16	43-7/16	12-15/16	13-3/8	78	88

20°

35°

Note: Also available in standard mount designated by SMI.

CEMA C IDLERS

TROUGHING IDLERS (EQUAL LENGTH ROLLERS) – 4" DIAMETER

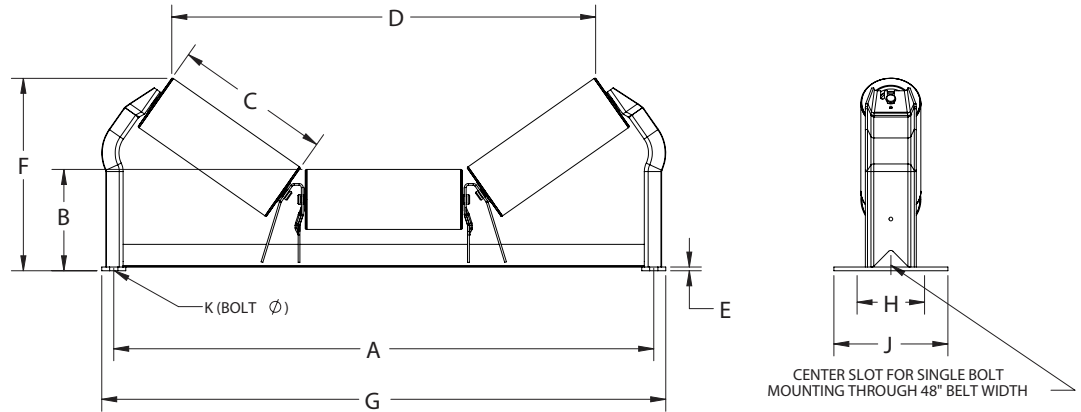

	4" PART NUMBER*	BW	A	B	C	D	E	F	G	H**	J	K	WT (#)
20°	C4-20E-18	18	27	7-13/16	7	22-3/16	3/16	10-5/16	29	6	8	1/2	33
	C4-20E-24	24	33	7-15/16	9	27-15/16	5/16	11-1/16	35	6	9-1/2	5/8	40
	C4-20E-30	30	39	7-15/16	11	33-11/16	5/16	11-13/16	41	6	9-1/2	5/8	48
	C4-20E-36	36	45	7-15/16	13	39-7/16	5/16	12-1/2	47	6	9-1/2	5/8	54
	C4-20E-42	42	51	8-5/16	15	45-3/16	5/16	13-9/16	53	7-1/2	9-1/2	5/8	68
	C4-20E-48	48	57	8-5/16	17	51	5/16	14-1/4	59	7-1/2	9-1/2	5/8	75
	C4-20E-54	54	63	8-3/4	19	56-3/4	3/8	15-5/16	65-1/2	9	11	5/8	90
	C4-20E-60	60	69	8-3/4	21	62-1/2	3/8	16	71-1/2	9	11	5/8	97
35°	C4-35E-18	18	27	7-13/16	7	20-1/16	3/16	12	29	6	8	1/2	35
	C4-35E-24	24	33	7-15/16	9	25-5/16	5/16	13-5/16	35	6	9-1/2	5/8	42
	C4-35E-30	30	39	7-15/16	11	30-9/16	5/16	14-7/16	41	6	9-1/2	5/8	50
	C4-35E-36	36	45	7-15/16	13	35-7/8	5/16	15-5/8	47	6	9-1/2	5/8	56
	C4-35E-42	42	51	8-5/16	15	41-1/8	5/16	17-1/8	53	7-1/2	9-1/2	5/8	64
	C4-35E-48	48	57	8-5/16	17	46-3/8	5/16	18-5/16	59	7-1/2	9-1/2	5/8	78
	C4-35E-54	54	63	8-3/4	19	51-11/16	3/8	19-7/8	65-1/2	9	11	5/8	93
	C4-35E-60	60	69	8-3/4	21	56-15/16	3/8	21	71-1/2	9	11	5/8	101
45°	C4-45E-18	18	27	7-13/16	7	18-3/4	3/16	13-1/8	29	6	8	1/2	36
	C4-45E-24	24	33	7-15/16	9	23-9/16	5/16	14-5/8	35	6	9-1/2	5/8	43
	C4-45E-30	30	39	7-15/16	11	28-7/16	5/16	16-1/16	41	6	9-1/2	5/8	52
	C4-45E-36	36	45	7-15/16	13	33-1/4	5/16	17-1/2	47	6	9-1/2	5/8	58
	C4-45E-42	42	51	8-5/16	15	38-1/16	5/16	19-5/16	53	7-1/2	9-1/2	5/8	73
	C4-45E-48	48	57	8-5/16	17	42-15/16	5/16	20-11/16	59	7-1/2	9-1/2	5/8	80
	C4-45E-54	54	63	8-3/4	19	47-3/4	3/8	22-1/2	65-1/2	9	11	5/8	96
	C4-45E-60	60	69	8-3/4	21	52-9/16	3/8	23-15/16	71-1/2	9	11	5/8	104

CEMA C

*Add MOX to the end of the part number to replace steel cans with Moxie Rolls.
 ** Recommended Bolt Pattern - See page 75 for minimum and maximum dimensions.

CEMA C IDLERS

TROUGHING IDLERS (EQUAL LENGTH ROLLERS) – 5" DIAMETER

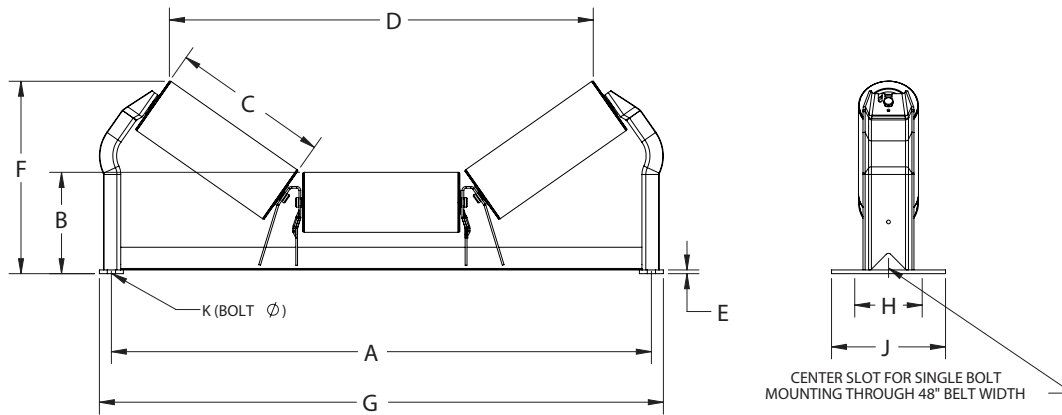

5" PART NUMBER*	BW	A	B	C	D	E	F	G	H**	J	K	WT (#)
C5-20E-18	18	27	8-5/16	7	21-7/8	3/16	10-3/4	29	6	8	1/2	39
C5-20E-24	24	33	8-7/16	9	27-5/8	5/16	11-9/16	35	6	9-1/2	5/8	47
C5-20E-30	30	39	8-7/16	11	33-7/16	5/16	12-5/16	41	6	9-1/2	5/8	57
C5-20E-36	36	45	8-7/16	13	39-3/16	5/16	12-15/16	47	6	9-1/2	5/8	64
C5-20E-42	42	51	8-13/16	15	44-15/16	5/16	14-1/16	53	7-1/2	9-1/2	5/8	80
C5-20E-48	48	57	8-13/16	17	50-11/16	5/16	14-3/4	59	7-1/2	9-1/2	5/8	88
C5-20E-54	54	63	9-1/4	19	56-7/16	3/8	15-13/16	65-1/2	9	11	5/8	104
C5-20E-60	60	69	9-1/4	21	63-3/16	3/8	16-1/2	71-1/2	9	11	5/8	113
C5-35E-18	18	27	8-5/16	7	19-9/16	3/16	12-7/16	29	6	8	1/2	41
C5-35E-24	24	33	8-7/16	9	24-13/16	5/16	13-11/16	35	6	9-1/2	5/8	49
C5-35E-30	30	39	8-7/16	11	30-1/16	5/16	14-7/8	41	6	9-1/2	5/8	59
C5-35E-36	36	45	8-7/16	13	35-3/8	5/16	16-1/16	47	6	9-1/2	5/8	67
C5-35E-42	42	51	8-13/16	15	40-5/8	5/16	17-9/16	53	7-1/2	9-1/2	5/8	82
C5-35E-48	48	57	8-13/16	17	45-15/16	5/16	18-11/16	59	7-1/2	9-1/2	5/8	91
C5-35E-54	54	63	9-1/4	19	51-1/8	3/8	20-1/4	65-1/2	9	11	5/8	108
C5-35E-60	60	69	9-1/4	21	56-7/16	3/8	21-7/16	71-1/2	9	11	5/8	117
C5-45E-18	18	27	8-5/16	7	18-1/16	3/16	13-7/16	29	6	8	1/2	42
C5-45E-24	24	33	8-7/16	9	22-7/8	5/16	15	35	6	9-1/2	5/8	50
C5-45E-30	30	39	8-7/16	11	27-13/16	5/16	16-7/16	41	6	9-1/2	5/8	61
C5-45E-36	36	45	8-7/16	13	32-9/16	5/16	17-7/8	47	6	9-1/2	5/8	68
C5-45E-42	42	51	8-13/16	15	37-7/16	5/16	19-5/8	53	7-1/2	9-1/2	5/8	84
C5-45E-48	48	57	8-13/16	17	42-1/4	5/16	21-1/16	59	7-1/2	9-1/2	5/8	93
C5-45E-54	54	63	9-1/4	19	47-1/16	3/8	22-7/8	65-1/2	9	11	5/8	110
C5-45E-60	60	69	9-1/4	21	51-7/16	3/8	27-5/16	71-1/2	9	11	5/8	120

20°

35°

45°

*Add MOX to the end of the part number to replace steel cans with Moxie Rolls.

** Recommended Bolt Pattern - See page 75 for minimum and maximum dimensions.

CEMA C IDLERS

TROUGHED IDLERS (EQUAL LENGTH ROLLERS) – 6" DIAMETER

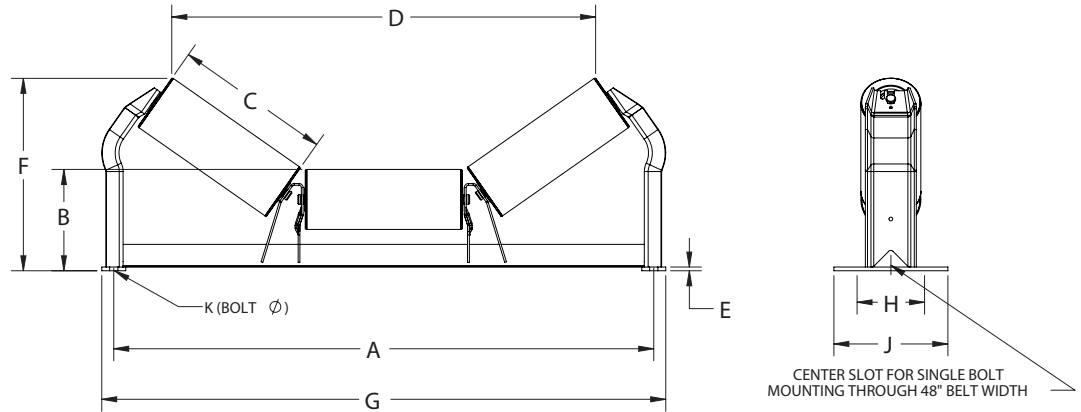

	6" PART NUMBER*	BW	A	B	C	D	E	F	G	H**	J	K	WT (#)
20°	C6-20E-18	18	27	8-13/16	7	21-9/16	3/16	11-1/4	29	6	8	1/2	46
	C6-20E-24	24	33	8-15/16	9	27-5/16	5/16	12-1/16	35	6	9-1/2	5/8	57
	C6-20E-30	30	39	8-15/16	11	33-1/16	5/16	12-3/4	41	6	9-1/2	5/8	69
	C6-20E-36	36	45	8-15/16	13	38-7/8	5/16	13-7/16	47	6	9-1/2	5/8	78
	C6-20E-42	42	51	9-5/16	15	44-5/8	5/16	14-1/2	53	7-1/2	9-1/2	5/8	95
	C6-20E-48	48	57	9-5/16	17	50-3/8	5/16	15-3/16	59	7-1/2	9-1/2	5/8	105
	C6-20E-54	54	63	9-3/4	19	56-1/8	3/8	16-5/16	65-1/2	9	11	5/8	124
	C6-20E-60	60	69	9-3/4	21	61-7/8	3/8	17	71-1/2	9	11	5/8	135
35°	C6-35E-18	18	27	8-13/16	7	18-15/16	3/16	12-13/16	29	6	8	1/2	48
	C6-35E-24	24	33	8-15/16	9	24-1/4	5/16	14-1/8	35	6	9-1/2	5/8	59
	C6-35E-30	30	39	8-15/16	11	29-1/2	5/16	15-1/4	41	6	9-1/2	5/8	71
	C6-35E-36	36	45	8-15/16	13	34-13/16	5/16	16-7/16	47	6	9-1/2	5/8	80
	C6-35E-42	42	51	9-5/16	15	40-1/16	5/16	17-15/16	53	7-1/2	9-1/2	5/8	98
	C6-35E-48	48	57	9-5/16	17	45-3/8	5/16	19-1/8	59	7-1/2	9-1/2	5/8	109
	C6-35E-54	54	63	9-3/4	19	50-5/8	3/8	20-11/16	65-1/2	9	11	5/8	128
	C6-35E-60	60	69	9-3/4	21	55-15/16	3/8	21-13/16	71-1/2	9	11	5/8	139
45°	C6-45E-18	18	27	8-13/16	7	17-7/16	3/16	13-3/4	29	6	8	1/2	49
	C6-45E-24	24	33	8-15/16	9	22-1/4	5/16	15-5/16	35	6	9-1/2	5/8	60
	C6-45E-30	30	39	8-15/16	11	27-1/8	5/16	16-3/4	41	6	9-1/2	5/8	73
	C6-45E-36	36	45	8-15/16	13	31-15/16	5/16	18-3/16	47	6	9-1/2	5/8	82
	C6-45E-42	42	51	9-5/16	15	36-3/4	5/16	19-15/16	53	7-1/2	9-1/2	5/8	100
	C6-45E-48	48	57	9-5/16	17	41-5/8	5/16	21-3/8	59	7-1/2	9-1/2	5/8	111
	C6-45E-54	54	63	9-3/4	19	46-7/16	3/8	23-3/16	65-1/2	9	11	5/8	130
	C6-45E-60	60	69	9-3/4	21	51-1/4	3/8	24-5/8	71-1/2	9	11	5/8	141

CEMA C

*Add MOX to the end of the part number to replace steel cans with Moxie Rolls.
 ** Recommended Bolt Pattern - See page 75 for minimum and maximum dimensions.

CEMA C IDLERS

RETURN IDLERS – 4", 5" AND 6" DIAMETER

PART NUMBER*			BW	A	B	C	WT (#)**		
4"	5"	6"					4"	5"	6"
C4-RET-16	C5-RET-16	C6-RET-16	16	25	19-5/16	26-7/16	16	21	27
C4-RET-18	C5-RET-18	C6-RET-18	18	27	21-5/16	28-7/16	17	23	30
C4-RET-20	C5-RET-20	C6-RET-20	20	29	23-5/16	30-7/16	18	24	31
C4-RET-24	C5-RET-24	C6-RET-24	24	33	27-5/16	34-7/16	21	27	37
C4-RET-30	C5-RET-30	C6-RET-30	30	39	33-5/16	40-7/16	24	32	43
C4-RET-36	C5-RET-36	C6-RET-36	36	45	39-5/16	46-7/16	27	37	50
C4-RET-42	C5-RET-42	C6-RET-42	42	51	45-5/16	52-7/16	31	41	57
C4-RET-48	C5-RET-48	C6-RET-48	48	57	51-5/16	58-7/16	32	46	63
C4-RET-54 ✓	C5-RET-54 ✓	C6-RET-54 ✓	54	63	57-5/16	64-7/16	42	54	74
C4-RET-60 ✓	C5-RET-60 ✓	C6-RET-60 ✓	60	69	63-5/16	70-7/16	45	60	81

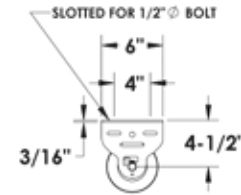
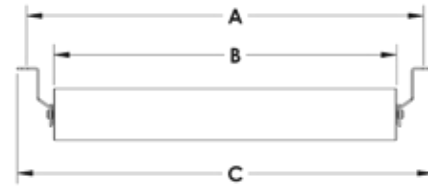

FLAT IDLERS – 4", 5", & 6" DIAMETER

PART NUMBER			BW	A	B	C	WT (#)**		
4"	5"	6"					4"	5"	6"
C4-FLT-16	C5-FLT-16	-	16	25	19-5/16	26-15/16	19	23	-
C4-FLT-18	C5-FLT-18	C6-FLT-18	18	27	21-5/16	28-15/16	20	25	32
C4-FLT-20	C5-FLT-20	C6-FLT-20	20	29	23-5/16	30-15/16	21	27	34
C4-FLT-24	C5-FLT-24	C6-FLT-24	24	33	27-5/16	34-15/16	23	30	39
C4-FLT-30	C5-FLT-30	C6-FLT-30	30	39	33-5/16	40-15/16	26	34	46
C4-FLT-36	C5-FLT-36	C6-FLT-36	36	45	39-5/16	46-15/16	30	39	52
C4-FLT-42	C5-FLT-42	C6-FLT-42	42	51	45-5/16	52-15/16	33	44	59
C4-FLT-48	C5-FLT-48	C6-FLT-48	48	57	51-5/16	58-15/16	36	48	66
C4-FLT-54 ✓	C5-FLT-54 ✓	C6-FLT-54 ✓	54	63	57-5/16	64-15/16	44	57	76
C4-FLT-60 ✓	C5-FLT-60 ✓	C6-FLT-60 ✓	60	69	63-5/16	70-15/16	48	63	84

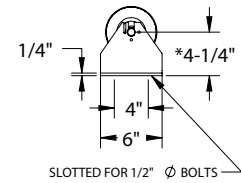
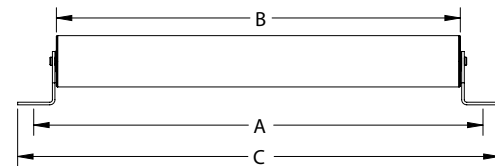

Note: Specify rise bracket requirement

GARLAND IDLERS – 4", 5", & 6" DIAMETER

4" PART NUMBER	BW	# OF ROLLS	A	B	C	WT (#)
43-3400-16	16	3	21-5/16	8-1/16	6-1/16	15
43-3400-18	18	3	21-5/16	8-1/16	6-1/16	17
43-3400-24	24	3	25-7/8	9-11/16	7-11/16	20
43-3400-30	30	5	32-5/8	8-1/16	6-1/16	28
43-3400-36	36	5	36-13/16	9-1/16	7	31
43-3400-42	42	5	45-1/8	11-1/16	9	36
43-3400-48	48	5	53-7/16	13-1/16	11	42
43-3400-54	54	5	61-13/16	15-1/16	13	47
43-3400-60	60	5	70-1/8	17-1/16	15	53

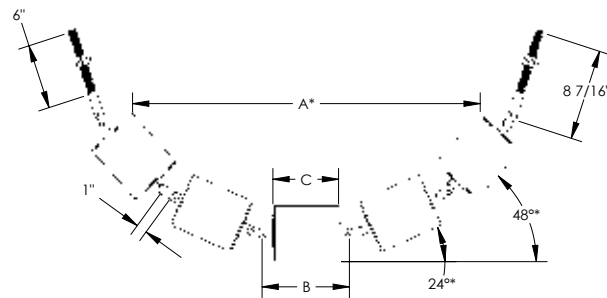

5" PART NUMBER	BW	# OF ROLLS	A	B	C	WT (#)
43-3500-16	16	3	20-15/16	8-1/16	6-1/16	22
43-3500-18	18	3	20-15/16	8-1/16	6-1/16	22
43-3500-24	24	3	25-1/2	9-11/16	7-11/16	26
43-3500-30	30	5	32-3/16	8-1/16	6-1/16	37
43-3500-36	36	5	36-3/8	9-1/16	7	41
43-3500-42	42	5	44-11/16	11-1/16	9	48
43-3500-48	48	5	53	13-1/16	11	56
43-3500-54	54	5	61-3/8	15-1/16	13	64
43-3500-60	60	5	69-11/16	17-1/16	15	72

6" PART NUMBER	BW	# OF ROLLS	A	B	C	WT (#)
43-3600-16	16	3	20-9/16	8-1/16	6-1/16	22
43-3600-18	18	3	20-9/16	8-1/16	6-1/16	22
43-3600-24	24	3	25-3/16	9-11/16	7-11/16	26
43-3600-30	30	5	31-9/16	8-1/16	6-1/16	37
43-3600-36	36	5	35-11/16	9-1/16	7	41
43-3600-42	42	5	44	11-1/16	9	48
43-3600-48	48	5	52-3/8	13-1/16	11	56
43-3600-54	54	5	60-11/16	15-1/16	13	64
43-3600-60	60	5	69	17-1/16	15	72

*Add MOX to the end of the part number to replace steel cans with Moxie Rolls.

**All weights include brackets, individual bracket weights are listed on page 74 and 75. Brackets not included. ✓ Meets CEMA D specifications.

CEMA C IDLERS

RUBBER CUSHION IMPACT TROUGHING IDLERS – 4" DIAMETER

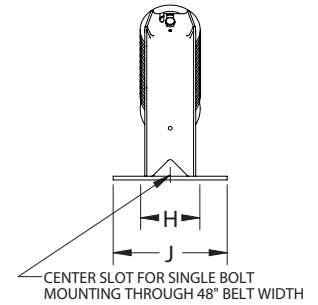
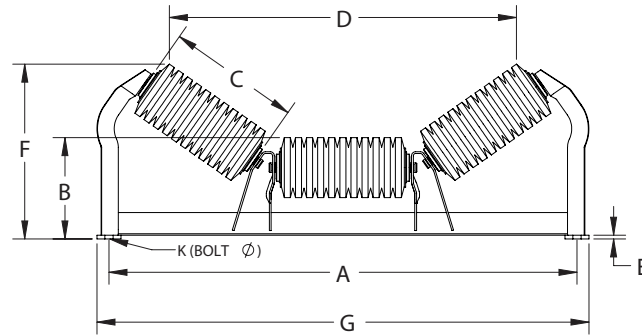

	4" PART NUMBER	BW*	A	B	C	D	E	F	G	H**	J	K	WT (#)
20°	C4-20EI-18	18	27	7-13/16	7-1/8	20-15/16	3/16	10-1/8	29	6	8	1/2	36
	C4-20EI-24	24	33	7-15/16	9-1/8	26-11/16	5/16	10-15/16	35	6	9-1/2	5/8	44
	C4-20EI-30	30	39	7-15/16	11-1/8	32-1/2	5/16	11-5/16	41	6	9-1/2	5/8	54
	C4-20EI-36	36	45	7-15/16	13-1/8	38-5/16	5/16	12-5/16	47	6	9-1/2	5/8	69
	C4-20EI-42	42	51	8-5/16	15-1/8	44-1/16	5/16	13-3/8	53	7-1/2	9-1/2	5/8	86
	C4-20EI-48	48	57	8-5/16	17-1/8	49-13/16	5/16	14-1/16	59	7-1/2	9-1/2	5/8	94
	C4-20EI-54	54	63	8-3/4	19-1/8	55-5/8	3/8	15-3/16	65-1/2	9	11	5/8	114
	C4-20EI-60	60	69	8-3/4	21-1/8	61-3/8	3/8	15-7/8	71-1/2	9	11	5/8	123
35°	C4-35EI-18	18	27	7-13/16	7-1/8	18-15/16	3/16	11-11/16	29	6	8	1/2	37
	C4-35EI-24	24	33	7-15/16	9-1/8	24-3/16	5/16	13	35	6	9-1/2	5/8	46
	C4-35EI-30	30	39	7-15/16	11-1/8	29-1/2	5/16	14-3/16	41	6	9-1/2	5/8	56
	C4-35EI-36	36	45	7-15/16	13-1/8	34-13/16	5/16	15-5/16	47	6	9-1/2	5/8	71
	C4-35EI-42	42	51	8-5/16	15-1/8	40-1/8	5/16	16-13/16	53	7-1/2	9-1/2	5/8	89
	C4-35EI-48	48	57	8-5/16	17-1/8	45-3/8	5/16	18	59	7-1/2	9-1/2	5/8	98
	C4-35EI-54	54	63	8-3/4	19-1/8	50-11/16	3/8	19-9/16	65-1/2	9	11	5/8	118
	C4-35EI-60	60	69	8-3/4	21-1/8	55-15/16	3/8	20-11/16	71-1/2	9	11	5/8	127
45°	C4-45EI-18	18	27	7-13/16	7-1/8	17-3/4	3/16	12-11/16	29	6	8	1/2	39
	C4-45EI-24	24	33	7-15/16	9-1/8	22-9/16	5/16	14-1/4	35	6	9-1/2	5/8	47
	C4-45EI-30	30	39	7-15/16	11-1/8	27-7/16	5/16	15-11/16	41	6	9-1/2	5/8	58
	C4-45EI-36	36	45	7-15/16	13-1/8	32-7/8	5/16	16-9/16	47	6	9-1/2	5/8	74
	C4-45EI-42	42	51	8-5/16	15-1/8	37-11/16	5/16	18-5/16	53	7-1/2	9-1/2	5/8	91
	C4-45EI-48	48	57	8-5/16	17-1/8	42-1/2	5/16	20-3/4	59	7-1/2	9-1/2	5/8	100
	C4-45EI-54	54	63	8-3/4	19-1/8	47-5/16	3/8	21-3/8	65-1/2	9	11	5/8	120
	C4-45EI-60	60	69	8-3/4	21-1/8	52-3/16	3/8	23	71-1/2	9	11	5/8	130

* Belt Width (Reinforcing on 36" BW - 60" BW Impact Frame).

** Recommended Bolt Pattern - See page 75 for minimum and maximum dimensions.

CEMA C IDLERS

RUBBER CUSHION IMPACT TROUGHING IDLERS – 5" DIAMETER

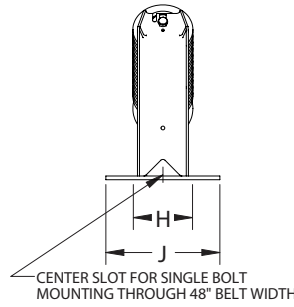
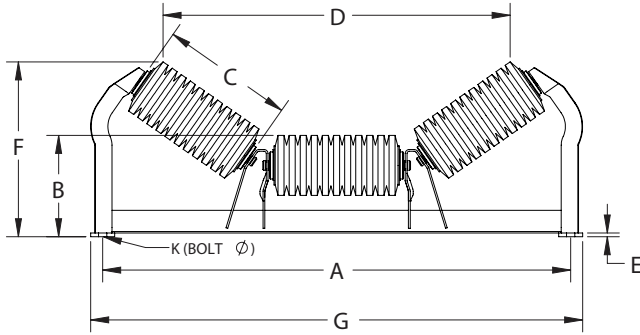

CEMA C

5" PART NUMBER	BW*	A	B	C	D	E	F	G	H**	J	K	WT (#)
C5-20EI-18	18	27	8-5/16	7-1/16	20-7/8	3/16	10-5/8	29	6	8	1/2	40
C5-20EI-24	24	33	8-7/16	9-11/16	26-5/8	5/16	11-7/16	35	6	9-1/2	5/8	50
C5-20EI-30	30	39	8-7/16	11-1/16	32-5/16	5/16	12-3/16	41	6	9-1/2	5/8	61
C5-20EI-36	36	45	8-7/16	13-1/16	38-1/16	5/16	12-7/8	47	6	9-1/2	5/8	77
C5-20EI-42	42	51	8-13/16	15-1/16	43-13/16	5/16	13-15/16	53	7-1/2	9-1/2	5/8	95
C5-20EI-48	48	57	8-13/16	17-1/16	49-9/16	5/16	14-5/8	59	7-1/2	9-1/2	5/8	105
C5-20EI-54	54	63	9-1/4	19-1/16	56-3/16	3/8	15-3/4	65-1/2	9	11	5/8	124
C5-20EI-60	60	69	9-1/4	21-1/16	61-15/16	3/8	16-7/16	71-1/2	9	11	5/8	136
C5-35EI-18	18	27	8-5/16	7-1/16	18-9/16	3/16	12-3/16	29	6	8	1/2	42
C5-35EI-24	24	33	8-7/16	9-1/16	23-13/16	5/16	13-7/16	35	6	9-1/2	5/8	52
C5-35EI-30	30	39	8-7/16	11-1/16	29-1/16	5/16	14-5/8	41	6	9-1/2	5/8	63
C5-35EI-36	36	45	8-7/16	13-1/16	34-3/8	5/16	15-3/4	47	6	9-1/2	5/8	79
C5-35EI-42	42	51	8-13/16	15-1/16	39-5/8	5/16	17-5/16	53	7-1/2	9-1/2	5/8	100
C5-35EI-48	48	57	8-13/16	17-1/16	44-7/8	5/16	18-7/16	59	7-1/2	9-1/2	5/8	110
C5-35EI-54	54	63	9-1/4	19-1/16	50-13/16	3/8	20-1/8	65-1/2	9	11	5/8	128
C5-35EI-60	60	69	9-1/4	21-1/16	56-1/8	3/8	21-1/4	71-1/2	9	11	5/8	140
C5-45EI-18	18	27	8-5/16	7-1/16	17-1/4	3/16	13-1/8	29	6	8	1/2	43
C5-45EI-24	24	33	8-7/16	9-1/16	22-1/16	5/16	14-11/16	35	6	9-1/2	5/8	53
C5-45EI-30	30	39	8-7/16	11-1/16	26-7/8	5/16	16-1/8	41	6	9-1/2	5/8	65
C5-45EI-36	36	45	8-7/16	13-1/16	31-11/16	5/16	17-1/2	47	6	9-1/2	5/8	81
C5-45EI-42	42	51	8-13/16	15-1/16	36-1/2	5/16	19-5/16	53	7-1/2	9-1/2	5/8	102
C5-45EI-48	48	57	8-13/16	17-1/16	41-5/16	5/16	20-3/4	59	7-1/2	9-1/2	5/8	112
C5-45EI-54	54	63	9-1/4	19-1/16	46-3/4	3/8	22-11/16	65-1/2	9	11	5/8	128
C5-45EI-60	60	69	9-1/4	21-1/16	51-9/16	3/8	24-1/16	71-1/2	9	11	5/8	143

20°

35°

45°

* Belt Width (Reinforcing on 36" BW - 60" BW Impact Frame).

** Recommended Bolt Pattern - See page 75 for minimum and maximum dimensions.

CEMA C IDLERS

RUBBER CUSHION IMPACT TROUGHING IDLERS – 6" DIAMETER

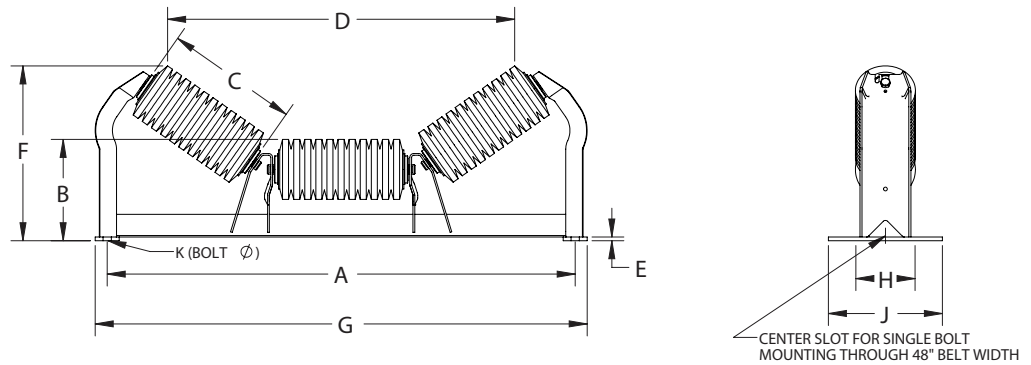

	6" PART NUMBER	BW*	A	B	C	D	E	F	G	H**	J	K	WT (#)
20°	C6-20EI-18	18	27	8-13/16	7-1/16	20-1/2	3/16	11-1/8	29	6	8	1/2	46
	C6-20EI-24	24	33	8-15/16	9-1/16	26-1/4	5/16	11-15/16	35	6	9-1/2	5/8	57
	C6-20EI-30	30	39	8-15/16	11-1/16	31-15/16	5/16	12-5/8	41	6	9-1/2	5/8	71
	C6-20EI-36	36	45	8-15/16	13-1/16	37-3/4	5/16	13-5/16	47	6	9-1/2	5/8	88
	C6-20EI-42	42	51	9-5/16	15-1/16	43-7/16	5/16	14-3/8	53	7-1/2	9-1/2	5/8	108
	C6-20EI-48	48	57	9-5/16	17-1/16	49-3/16	5/16	15-1/16	59	7-1/2	9-1/2	5/8	119
	C6-20EI-54	54	63	9-3/4	19	55-13/16	3/8	16-1/4	65-1/2	9	11	5/8	141
	C6-20EI-60	60	69	9-3/4	21	61-9/16	3/8	16-15/16	71-1/2	9	11	5/8	155
35°	C6-35EI-18	18	27	8-13/16	7-1/16	18	1/4	12-5/8	29	6	8	1/2	48
	C6-35EI-24	24	33	8-15/16	9-1/16	23-1/4	5/16	13	35	6	9-1/2	5/8	59
	C6-35EI-30	30	39	8-15/16	11-1/16	28-1/2	5/16	15-1/16	41	6	9-1/2	5/8	73
	C6-35EI-36	36	45	8-15/16	13-1/16	33-11/16	5/16	16-3/16	47	6	9-1/2	5/8	90
	C6-35EI-42	42	51	9-5/16	15-1/16	39	5/16	17-11/16	53	7-1/2	9-1/2	5/8	112
	C6-35EI-48	48	57	9-5/16	17-1/16	44-5/16	5/16	18-7/8	59	7-1/2	9-1/2	5/8	124
	C6-35EI-54	54	63	9-3/4	19	50-1/4	3/8	20-1/2	65-1/2	9	11	5/8	142
	C6-35EI-60	60	69	9-3/4	21	55-1/2	3/8	21-11/16	71-1/2	9	11	5/8	144
45°	C6-45EI-18	18	27	8-15/16	7	17-7/16	3/16	13-3/4	29	6	8	1/2	49
	C6-45EI-24	24	33	8-15/16	9	22-1/4	5/16	15-5/16	35	6	9-1/2	5/8	61
	C6-45EI-30	30	39	8-15/16	11	27-1/8	5/16	16-3/4	41	6	9-1/2	5/8	74
	C6-45EI-36	36	45	8-15/16	13	31-15/16	5/16	18-3/16	47	6	9-1/2	5/8	92
	C6-45EI-42	42	51	9-5/16	15	36-3/4	5/16	19-15/16	53	7-1/2	9-1/2	5/8	115
	C6-45EI-48	48	57	9-5/16	17	41-5/8	5/16	21-3/8	59	7-1/2	9-1/2	5/8	127
	C6-45EI-54	54	63	9-3/4	19	46-1/16	3/8	23	65-1/2	9	11	5/8	147
	C6-45EI-60	60	69	9-3/4	21	50-7/8	3/8	24-7/16	71-1/2	9	11	5/8	162

CEMA C

* Belt Width (Reinforcing on 36" BW - 60" BW Impact Frame).

** Recommended Bolt Pattern - See page 75 for minimum and maximum dimensions.

CEMA C IDLERS

RUBBER CUSHION RETURN IDLERS – 4", 5", & 6" DIAMETER

PART NUMBER			BW	A	B	C	WT (#)*		
4"	5"	6"					4"	5"	6"
C4-RETI-18	C5-RETI-18	C6-RETI-18	18	27	21-3/8	28-7/16	20	23	26
C4-RETI-20	C5-RETI-20	C6-RETI-20	20	29	23-3/8	30-7/16	22	25	29
C4-RETI-24	C5-RETI-24	C6-RETI-24	24	33	27-3/8	34-7/16	25	28	32
C4-RETI-30	C5-RETI-30	C6-RETI-30	30	39	33-3/8	40-7/16	29	32	37
C4-RETI-36	C5-RETI-36	C6-RETI-36	36	45	39-3/8	46-7/16	34	37	43
C4-RETI-42	C5-RETI-42	C6-RETI-42	42	51	45-3/8	52-7/16	38	42	47
C4-RETI-48	C5-RETI-48	C6-RETI-48	48	57	51-3/8	58-7/16	42	46	51
C4-RETI-54 ✓	C5-RETI-54 ✓	C6-RETI-54 ✓	54	63	57-3/8	64-7/16	50	54	60
C4-RETI-60 ✓	C5-RETI-60 ✓	C6-RETI-60 ✓	60	69	63-3/8	70-7/16	55	60	66

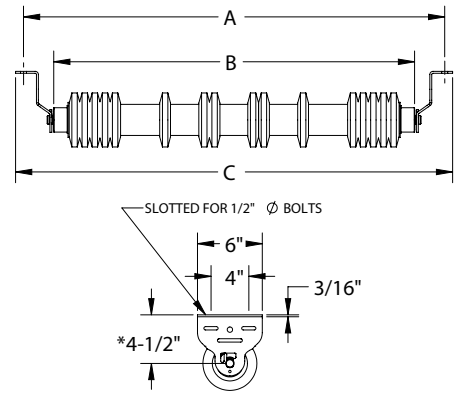

RUBBER CUSHION FLAT IDLERS – 4", 5", & 6" DIAMETER

PART NUMBER			BW	A	B	C	WT (#)*		
4"	5"	6"					4"	5"	6"
C4-FLTI-18	C5-FLTI-18	C6-FLTI-18	18	27	21-7/16	28-15/16	25	30	36
C4-FLTI-20	C5-FLTI-20	C6-FLTI-20	20	29	23-7/16	30-15/16	26	31	38
C4-FLTI-24	C5-FLTI-24	C6-FLTI-24	24	33	27-7/16	34-15/16	30	36	44
C4-FLTI-30	C5-FLTI-30	C6-FLTI-30	30	39	33-7/16	40-15/16	35	43	53
C4-FLTI-36	C5-FLTI-36	C6-FLTI-36	36	45	39-7/16	46-15/16	40	49	62
C4-FLTI-42	C5-FLTI-42	C6-FLTI-42	42	51	45-7/16	52-15/16	45	56	70
C4-FLTI-48	C5-FLTI-48	C6-FLTI-48	48	57	51-7/16	58-15/16	51	63	79
C4-FLTI-54 ✓	C5-FLTI-54 ✓	C6-FLTI-54 ✓	54	63	57-7/16	64-15/16	60	73	91
C4-FLTI-60 ✓	C5-FLTI-60 ✓	C6-FLTI-60 ✓	60	69	63-7/16	70-15/16	65	80	100

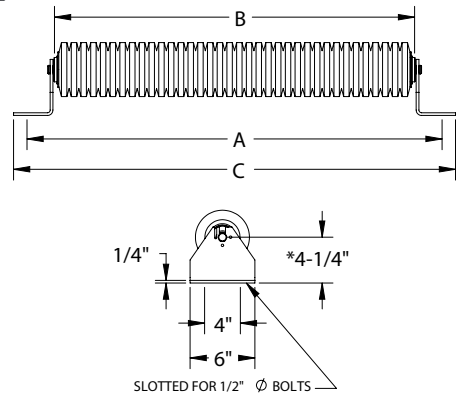

V-RETURN IDLERS – 4", 5", & 6" DIAMETER

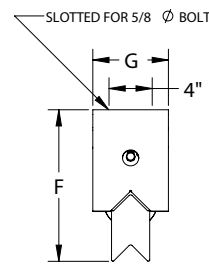
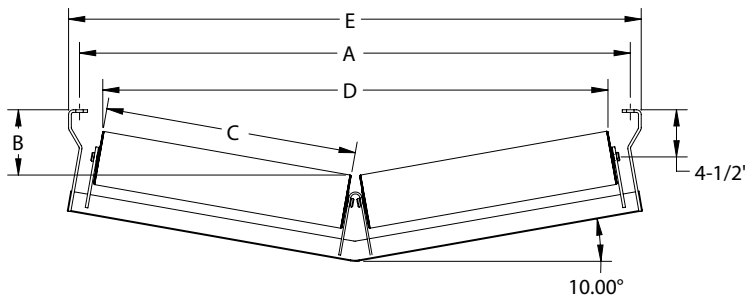

FOR WIDE BASE USE NEXT SIZE LARGER BELT WIDTH. ALSO AVAILABLE IN 15°.

PART NUMBER			BW	A	B			C	D			E	F	WT (#)		
4"	5"	6"			4"	5"	6"		4"	5"	6"			4"	5"	6"
C4-10RETV-24	C5-10RETV-24	C6-10RETV-24	24	33	4-15/16	4-7/16	3-15/16	14-3/8	28-7/8	28-13/16	28-5/8	35-1/8	12-3/8	42	49	58
C4-10RETV-30	C5-10RETV-30	C6-10RETV-30	30	39	5-1/2	5	4-1/2	17	34-3/16	34-1/16	33-7/8	41-1/8	12-7/8	46	55	67
C4-10RETV-36	C5-10RETV-36	C6-10RETV-36	36	45	6	5-1/2	5	20-3/8	40-15/16	40-7/8	40-11/16	47-1/8	13-3/8	52	62	74
C4-10RETV-42	C5-10RETV-42	C6-10RETV-42	42	51	6-1/2	6-1/16	5-9/16	23-3/8	46-5/8	46-1/2	46-3/8	53-1/8	14	56	68	82
C4-10RETV-48	C5-10RETV-48	C6-10RETV-48	48	57	7-1/16	6-9/16	6-1/16	26-1/2	52-7/8	52-3/4	52-9/16	59-1/8	14-1/2	61	74	92
C4-10RETV-54	C5-10RETV-54	C6-10RETV-54	54	63	7-9/16	7-1/8	6-5/8	29-1/4	58-3/16	58-1/8	57-15/16	65-1/8	15-3/8	82	96	114
C4-10RETV-60	C5-10RETV-60	C6-10RETV-60	60	69	8-1/8	7-5/8	7-1/8	32-1/2	64-11/16	64-9/16	64-3/8	71-1/8	15-7/8	89	105	127

*All weights include brackets, Individual bracket weights are listed on page 74 and 75. Brackets are sold separately. ✓ Meets CEMA D specs.

CEMA C IDLERS

URATHON® RETURN ROLLS – 5" & 6" DIAMETER

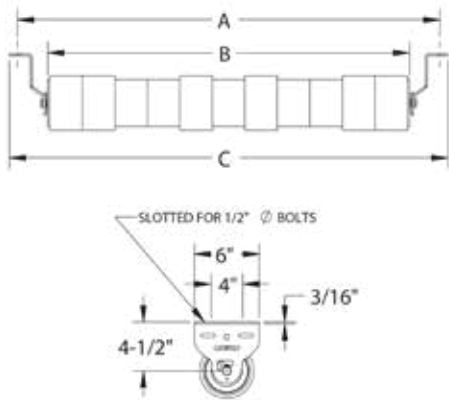

PART NUMBERS		BW	A	B	C	WT (#)**	
5"	6"					5"	6"
C5-RETU-18	C6-RETU-18	18	27	21-3/8	28-7/16	22	28
C5-RETU-24	C6-RETU-24	24	33	27-3/8	34-7/16	25	33
C5-RETU-30	C6-RETU-30	30	39	33-3/8	40-7/16	30	39
C5-RETU-36	C6-RETU-36	36	45	39-3/8	46-7/16	34	45
C5-RETU-42	C6-RETU-42	42	51	45-3/8	52-7/16	38	50
C5-RETU-48	C6-RETU-48	48	57	51-3/8	58-7/16	42	56
C5-RETU-54	C6-RETU-54	54	63	57-3/8	64-7/16	50	66
C5-RETU-60	C6-RETU-60	60	69	63-3/8	70-7/16	55	72

Note: Spiral Uraction is only available in 6" diameter. To order Spiral Uraction version add SP after RETU in the part number.

SELF-ALIGNING TROUGHING IDLERS – 4" DIAMETER

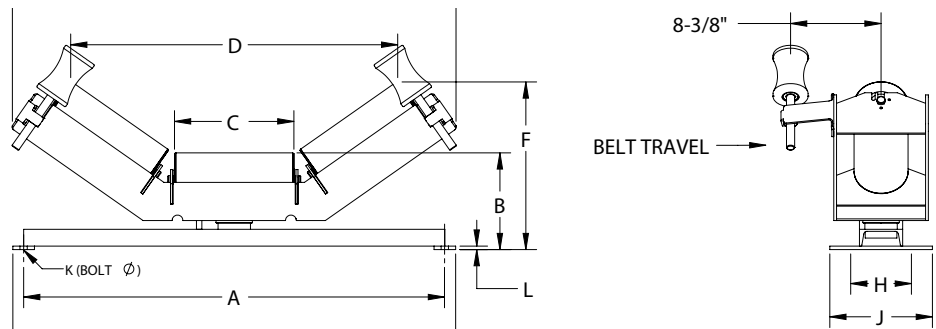

	4" PART NUMBER*	BW	A	B	C	D	E	F	G	H	J	K	L	WT(#)
20°	C4-20EA-18	18	27	8-3/8	7	23-3/16	31	11-1/16	29	6	8	1/2	3/16	80
	C4-20EA-24	24	33	8-1/2	9	28-15/16	36-3/4	11-7/8	35	6	9-1/2	1/2	5/16	91
	C4-20EA-30	30	39	8-1/2	11	34-11/16	42-9/16	12-9/16	41	6	9-1/2	1/2	5/16	100
	C4-20EA-36	36	45	8-1/2	13	40-7/16	48-5/16	13-1/4	47	6	9-1/2	1/2	5/16	109
	C4-20EA-42	42	51	9	15	46	54-3/16	14-7/16	53	7-1/2	9-1/2	5/8	5/16	123
	C4-20EA-48	48	57	9	17	51-3/4	60	15-1/8	59	7-1/2	9-1/2	5/8	5/16	133
	C4-20EA-54	54	63	9-1/16	19	57-1/2	65-3/4	15-7/8	65-1/2	9	11	5/8	3/8	145
C4-20EA-60	60	69	9-1/16	21	63-5/16	72-1/2	16-9/16	71-1/2	9	11	5/8	3/8	155	
35°	C4-35EA-18	18	27	8-3/8	7	20-1/4	30-3/8	12-3/4	29	6	8	1/2	3/16	81
	C4-35EA-24	24	33	8-1/2	9	25-9/16	35-11/16	14	35	6	9-1/2	1/2	5/16	91
	C4-35EA-30	30	39	8-1/2	11	30-13/16	40-15/16	15-1/8	41	6	9-1/2	1/2	5/16	101
	C4-35EA-36	36	45	8-1/2	13	36-1/16	46-1/4	16-5/16	47	6	9-1/2	1/2	5/16	110
	C4-35EA-42	42	51	9	15	41-1/16	51-3/16	17-15/16	53	7-1/2	9-1/2	5/8	5/16	123
	C4-35EA-48	48	57	9	17	46-5/16	56-1/2	19-1/8	59	7-1/2	9-1/2	5/8	5/16	133
	C4-35EA-54	54	63	9-1/16	19	51-5/8	61-3/4	20-5/16	65-1/2	9	11	5/8	3/8	145
C4-35EA-60	60	69	9-1/16	21	56-7/8	67	21-7/16	71-1/2	9	11	5/8	3/8	156	
45°	C4-45EA-18	18	27	8-3/8	7	19-7/16	30-11/16	13-5/8	29	6	8	1/2	3/16	82
	C4-45EA-24	24	33	8-1/2	9	24-1/4	35-1/2	15-1/8	35	6	9-1/2	1/2	5/16	93
	C4-45EA-30	30	39	8-1/2	11	29-1/16	40-5/16	16-9/16	41	6	9-1/2	1/2	5/16	102
	C4-45EA-36	36	45	8-1/2	13	33-7/8	45-3/16	18	47	6	9-1/2	1/2	5/16	111
	C4-45EA-42	42	51	9	15	38-5/16	50-5/16	20-1/4	53	7-1/2	9-1/2	5/8	5/16	137
	C4-45EA-48	48	57	9	17	43-1/8	55-1/8	21-5/16	59	7-1/2	9-1/2	5/8	5/16	135
C4-45EA-54	54	63	9-1/16	19	47-15/16	59-15/16	22-13/16	65-1/2	9	11	5/8	3/8	147	
C4-45EA-60	60	69	9-1/16	21	52-13/16	64-3/4	24-3/16	71-1/2	9	11	5/8	3/8	157	

*Also available in bi-directional shoe-activating. Designated by (BA).

** Weight of bracket included. Individual bracket weights are listed on page 74 and 75. Brackets are sold separately.

CEMA C IDLERS

SELF-ALIGNING TROUGHING IDLERS – 5" & 6" DIAMETER

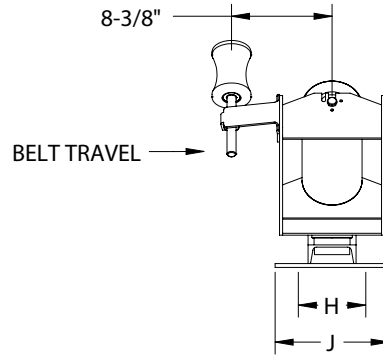
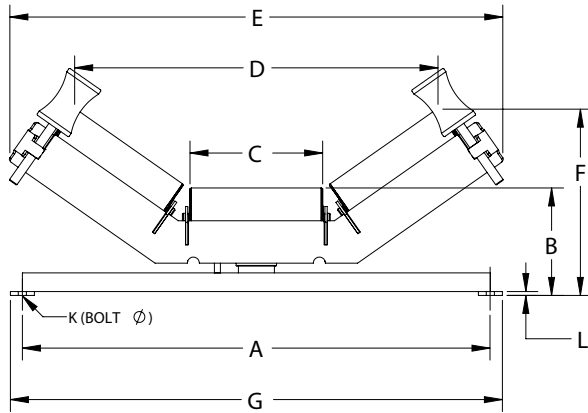

CEMA C

PART NUMBER*		BW	A	B		C		D		E	F		G	H	J	K	L	WT (#)	
5"	6"			5"	6"	5"	6"	5"	6"		5"	6"						5"	6"
C5-20EA-18	C6-20EA-18	18	27	8-7/8	9-3/8	7-1/16	7	22-7/8	22-9/16	31	11-9/16	12	29	6	8	1/2	3/16	86	94
C5-20EA-24	C6-20EA-24	24	33	9	9-1/2	9-1/16	9	28-5/8	28-5/16	36-3/4	12-3/8	12-13/16	35	6	9-1/2	1/2	5/16	98	108
C5-20EA-30	C6-20EA-30	30	39	9	9-1/2	11-1/16	11	34-3/8	34-1/16	42-9/16	13-1/16	13-1/2	41	6	9-1/2	1/2	5/16	109	121
C5-20EA-36	C6-20EA-36	36	45	9	9-1/2	13-1/16	13	40-1/8	39-13/16	48-5/16	13-3/4	14-3/16	47	6	9-1/2	1/2	5/16	120	134
C5-20EA-42	C6-20EA-42	42	51	9-1/2	10	15-1/16	15	45-3/4	45-3/8	54-3/16	14-15/16	15-3/8	53	7-1/2	9-1/2	5/8	5/16	134	150
C5-20EA-48	C6-20EA-48	48	57	9-1/2	10	17-1/16	17	51-1/2	51-1/8	60	15-5/8	16-1/16	59	7-1/2	9-1/2	5/8	5/16	146	163
C5-20EA-54	C6-20EA-54	54	63	9-9/16	10-1/16	19-1/16	19	57-1/4	56-15/16	65-3/4	16-3/8	16-13/16	65-1/2	9	11	5/8	3/8	160	179
C5-20EA-60	C6-20EA-60	60	69	9-9/16	10-1/16	21-1/16	21	63	62-11/16	71-1/2	17-1/16	17-1/2	71-1/2	9	11	5/8	3/8	171	192
C5-35EA-18	C6-35EA-18	18	27	8-7/8	9-3/8	7-1/16	7	19-3/4	19-3/16	30-3/8	13-1/8	13-9/16	29	6	8	1/2	3/16	87	94
C5-35EA-24	C6-35EA-24	24	33	9	9-1/2	9-1/16	9	25	24-1/2	35-11/16	14-7/16	14-13/16	35	6	9-1/2	1/2	5/16	98	109
C5-35EA-30	C6-35EA-30	30	39	9	9-1/2	11-1/16	11	30-5/16	29-3/4	40-15/16	15-09/16	15-15/16	41	6	9-1/2	1/2	5/16	109	122
C5-35EA-36	C6-35EA-36	36	45	9	9-1/2	13-1/16	13	35-9/16	35-1/16	46-1/4	16-11/16	17-1/8	47	6	9-1/2	1/2	5/16	120	134
C5-35EA-42	C6-35EA-42	42	51	9-1/2	10	15-1/16	15	40-1/2	40	51-3/16	18-3/8	18-3/4	53	7-1/2	9-1/2	5/8	5/16	135	151
C5-35EA-48	C6-35EA-48	48	57	9-1/2	10	17-1/16	17	45-13/16	45-1/4	56-1/2	19-1/2	19-7/8	59	7-1/2	9-1/2	5/8	5/16	146	164
C5-35EA-54	C6-35EA-54	54	63	9-9/16	10-1/16	19-1/16	19	51-1/16	50-9/16	61-3/4	20-11/16	21-1/8	65-1/2	9	11	5/8	3/8	160	180
C5-35EA-60	C6-35EA-60	60	69	9-9/16	10-1/16	21-1/16	21	56-3/8	55-13/16	67	21-7/8	22-1/4	71-1/2	9	11	5/8	3/8	171	193
C5-45EA-18	C6-45EA-18	18	27	8-7/8	9-3/8	7-1/16	7	18-3/4	18-1/8	30-11/16	14	14-5/16	29	6	8	1/2	3/16	88	95
C5-45EA-24	C6-45EA-24	24	33	9	9-1/2	9-1/16	9	23-9/16	22-15/16	35-1/2	15-1/2	15-13/16	35	6	9-1/2	1/2	5/16	100	110
C5-45EA-30	C6-45EA-30	30	39	9	9-1/2	11-1/16	11	28-7/16	27-3/4	40-5/16	16-15/16	17-1/4	41	6	9-1/2	1/2	5/16	111	123
C5-45EA-36	C6-45EA-36	36	45	9	9-1/2	13-1/16	13	33-1/4	32-9/16	45-1/4	18-3/16	18-5/8	47	6	9-1/2	1/2	5/16	122	136
C5-45EA-42	C6-45EA-42	42	51	9-1/2	10	15-1/16	15	37-5/8	37	50-5/16	20-1/4	20-9/16	53	7-1/2	9-1/2	5/8	5/16	137	152
C5-45EA-48	C6-45EA-48	48	57	9-1/2	10	17-1/16	17	42-1/2	41-13/16	55-1/8	21-11/16	22	59	7-1/2	9-1/2	5/8	5/16	148	166
C5-45EA-54	C6-45EA-54	54	63	9-9/16	10-1/16	19-1/16	19	47-5/16	46-11/16	59-15/16	23-3/16	23-7/16	65-1/2	9	11	5/8	3/8	162	181
C5-45EA-60	C6-45EA-60	60	69	9-9/16	10-1/16	21-1/16	21	52-1/8	51-1/2	64-3/4	24-9/16	24-7/8	71-1/2	9	11	5/8	3/8	171	193

20°

35°

45°

* Also available in bi-directional shoe-activated option. Designated by (BA).

CEMA C IDLERS

SELF-ALIGNING RETURN IDLER – 4", 5" & 6" DIAMETER

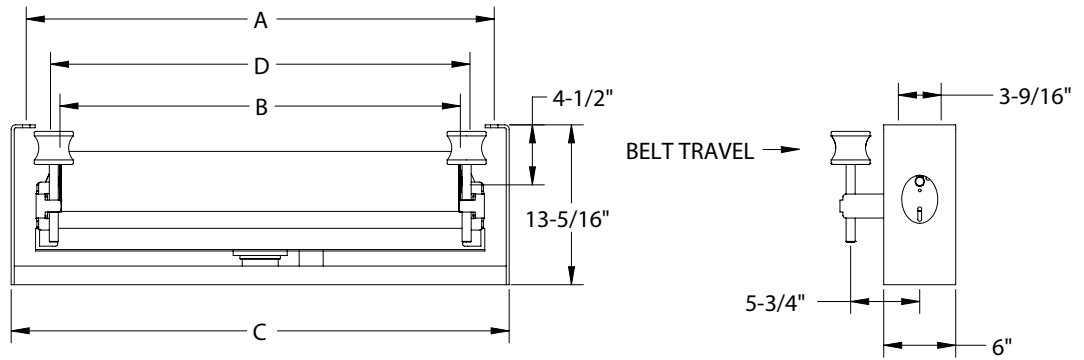

PART NUMBER			BW	A	B	C	D	WT (#)		
4"	5"	6"						4"	5"	6"
C4-RETA-18	C5-RETA-18	C6-RETA-18	18	27	21-3/8	29-1/2	25-5/8	63	69	76
C4-RETA-24	C5-RETA-24	C6-RETA-24	24	33	27-3/8	35-1/2	31-5/8	71	78	87
C4-RETA-30	C5-RETA-30	C6-RETA-30	30	39	33-3/8	41-1/2	37-11/16	82	90	101
C4-RETA-36	C5-RETA-36	C6-RETA-36	36	45	39-3/8	47-1/2	43-5/8	90	99	113
C4-RETA-42	C5-RETA-42	C6-RETA-42	42	51	45-3/8	53-1/2	49-5/8	106	117	132
C4-RETA-48	C5-RETA-48	C6-RETA-48	48	57	51-3/8	59-1/2	55-5/8	116	128	145
C4-RETA-54 ✓	C5-RETA-54 ✓	C6-RETA-54 ✓	54	63	57-3/8	65-1/2	61-5/8	129	142	162
C4-RETA-60 ✓	C5-RETA-60 ✓	C6-RETA-60 ✓	60	69	63-3/8	71-1/2	67-5/8	139	153	175

Bigfoot bolting pattern and lagged roller option available.

* Also available in bi-directional shoe-activated option. Designated by (RETBA). ✓ Meets CEMA D specifications. Self-aligning return idlers are also available in lagged roller. Designated by (RETAI).

CEMA C IDLERS

FEEDER / PICKING TROUGHING IDLERS – 4", 5", & 6" DIAMETER

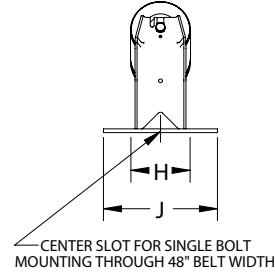
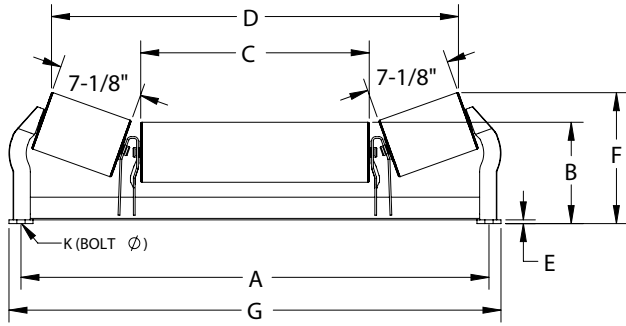

CEMA C

6" PART NUMBER	BW*	A	B	C	D	E	F	G	H**	J	K	WT (#)
C4-20P-24	24	33	7-15/16	13	28-1/8	5/16	10-3/8	35	6	9-1/2	5/8	39
C4-20P-30	30	39	7-15/16	19	34-1/8	5/16	10-7/16	41	6	9-1/2	5/8	47
C4-20P-36	36	45	7-15/16	25	40	5/16	10-7/16	47	6	9-1/2	5/8	52
C4-20P-42	42	51	8-5/16	30-3/4	46-1/16	5/16	10-7/16	53	6	9-1/2	5/8	66
C4-20P-48	48	57	8-5/16	36-3/4	52-1/4	5/16	10-7/16	51-3/4	6	9-1/2	5/8	72
C4-20P-54	54	63	8-3/4	42-7/16	57-15/16	3/8	11-3/16	65-1/2	9	11	5/8	87
C4-20P-60	60	69	8-3/4	48-7/16	63-15/16	3/8	11-3/16	71-1/2	9	11	5/8	94
C5-20P-24	24	33	8-7/16	13-1/16	27-13/16	5/16	10-7/8	35	6	9-1/2	5/8	47
C5-20P-30	30	39	8-7/16	19-1/16	33-7/8	5/16	10-7/8	41	6	9-1/2	5/8	56
C5-20P-36	36	45	8-7/16	25-1/16	39-7/8	5/16	10-7/8	47	6	9-1/2	5/8	63
C5-20P-42	42	51	8-13/16	30-13/16	46	5/16	10-15/16	53	6	9-1/2	5/8	77
C5-20P-48	48	57	8-13/16	36-13/16	52	5/16	11-3/16	59	6	9-1/2	5/8	85
C5-20P-54	54	63	9-1/4	42-1/2	57-5/8	3/8	11-11/16	65-1/2	9	11	5/8	101
C5-20P-60	60	69	9-1/4	48-1/2	63-5/8	3/8	11-11/16	71-1/2	9	11	5/8	109
C6-20P-24	24	33	8-15/16	13	27-1/2	5/16	11-3/8	35	6	9-1/2	5/8	56
C6-20P-30	30	39	8-15/16	19	33-1/2	5/16	11-3/8	41	6	9-1/2	5/8	67
C6-20P-36	36	45	8-15/16	25	39-1/2	5/16	11-3/8	47	6	9-1/2	5/8	76
C6-20P-42	42	51	9-5/16	30-13/16	45-3/4	5/16	11-7/16	53	6	9-1/2	5/8	91
C6-20P-48	48	57	9-5/16	36-13/16	51-3/4	5/16	11-3/8	59	6	9-1/2	5/8	101
C6-20P-54	54	63	9-3/4	42-9/16	57-5/16	3/8	12-1/8	65-1/2	9	11	5/8	118
C6-20P-60	60	69	9-3/4	48-9/16	63-5/16	3/8	12-1/8	71-1/2	9	11	5/8	128

4"

5"

6"

* Belt Width (Reinforcing on 36" BW - 60" BW Impact Frame only, use PI for part number).
 ** Recommended Bolt Pattern - See page 75 for minimum and maximum dimensions.
 Use PCI for part number when requiring impact rolls only in the center.

CEMA C IDLERS

TROUGHING IDLERS (UNEQUAL LENGTH ROLLS) – 4" DIAMETER

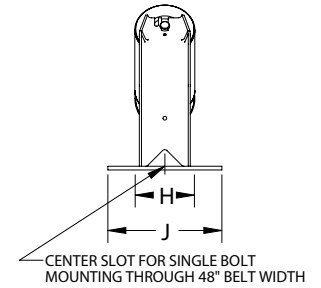
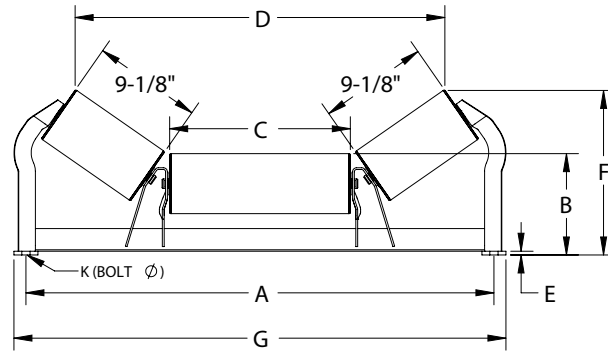

	4" PART NUMBER	BW*	A	B	C	D	E	F	G	H**	J	K	WT (#)
20°	C4-20U-30	30	39	7-15/16	15	33-7/8	5/16	11-1/8	41	6	9-1/2	5/8	47
	C4-20U-36	36	45	7-15/16	21	39-7/8	5/16	11-1/8	47	6	9-1/2	5/8	53
	C4-20U-42	42	51	8-5/16	26-1/2	46	5/16	11-1/8	53	7-1/2	9-1/2	5/8	66
	C4-20U-48	48	57	8-5/16	32-7/16	52	5/16	11-1/8	59	7-1/2	9-1/2	5/8	72
	C4-20U-54	54	63	8-3/4	38	58-1/16	3/8	11-1/4	65-1/2	9	11	5/8	81
	C4-20U-60	60	69	8-3/4	44	64-1/16	3/8	11-1/4	71-1/2	9	11	5/8	94
35°	C4-35U-30	30	39	7-15/16	15-1/16	31-1/4	5/16	13-1/4	41	6	9-1/2	5/8	49
	C4-35U-36	36	45	7-15/16	21	37-1/4	5/16	13-1/4	47	6	9-1/2	5/8	55
	C4-35U-42	42	51	8-5/16	26-1/4	41-5/8	5/16	14-11/16	53	7-1/2	9-1/2	5/8	69
	C4-35U-48	48	57	8-5/16	32-7/16	49-3/8	5/16	13-5/16	59	7-1/2	9-1/2	5/8	74
	C4-35U-54	54	63	8-3/4	38	55-3/8	3/8	13-7/16	65-1/2	9	11	5/8	89
	C4-35U-60	60	69	8-3/4	44	61-3/8	3/8	13-7/16	71-1/2	9	11	5/8	96
45°	C4-45U-30	30	39	7-15/16	15	29-9/16	5/16	14-5/8	41	6	9-1/2	5/8	51
	C4-45U-36	36	45	7-15/16	21	35-9/16	5/16	14-5/8	47	6	9-1/2	5/8	56
	C4-45U-42	42	51	8-5/16	26-1/4	41-5/8	5/16	14-11/16	53	7-1/2	9-1/2	5/8	70
	C4-45U-48	48	57	8-5/16	32-1/4	47-5/8	5/16	14-11/16	59	7-1/2	9-1/2	5/8	76
	C4-45U-54	54	63	8-3/4	37-9/16	53-5/8	3/8	14-13/16	65-1/2	9	11	5/8	90
	C4-45U-60	60	69	8-3/4	43-9/16	59-5/8	3/8	14-13/16	71-1/2	9	11	5/8	97

CEMA C

* Belt Width (Reinforcing on 36" BW - 60" BW Impact Frame only).

** Recommended Bolt Pattern - See page 73 for minimum and maximum dimensions.

Note: Also available in rubber cushioned roller. Designated by (UI).

CEMA C IDLERS

TROUGHING IDLERS (UNEQUAL LENGTH ROLLERS) – 5" & 6" DIAMETER

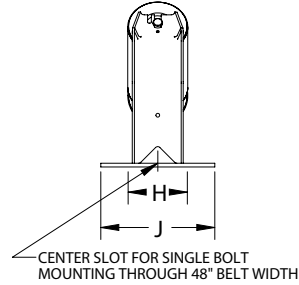
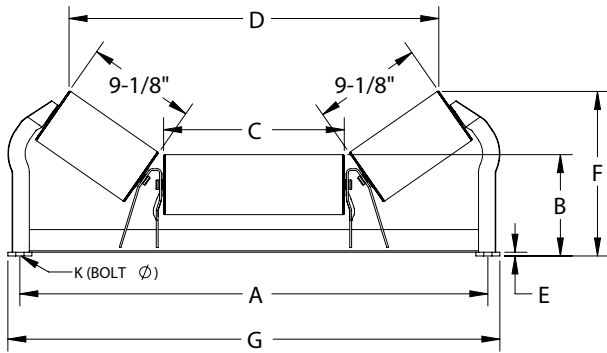

CEMA C

PART NUMBER		BW	A	B		C		D		E	F		G	H*	J	K	WT (#)	
5"	6"			5"	6"	5"	6"	5"	6"		5"	6"					5"	6"
C5-20U-30	C6-20U-30	30	39	8-7/16	8-5/16	15-1/16	15	33-5/8	33-1/4	5/16	11-9/16	12-1/16	41	6	9-1/2	5/8	57	68
C5-20U-36	C6-20U-36	36	45	8-7/16	8-15/16	21-1/16	21	39-5/8	39-1/4	5/16	11-9/16	12-1/16	47	6	9-1/2	5/8	63	77
C5-20U-42	C6-20U-42	42	51	8-13/16	9-5/16	26-9/16	26-9/16	45-3/4	45-7/16	5/16	11-5/8	12-11/16	53	7-1/2	9-1/2	5/8	78	93
C5-20U-48	C6-20U-48	48	57	8-13/16	9-5/16	32-9/16	32-9/16	51-3/4	51-7/16	5/16	11-5/8	12-1/8	59	7-1/2	9-1/2	5/8	85	102
C5-20U-54	C6-20U-54	54	63	9-1/4	9-3/4	38-1/16	38-1/16	57-7/8	57-9/16	3/8	11-3/4	12-3/16	65-1/2	9	11	5/8	101	119
C5-20U-60	C6-20U-60	60	69	9-1/4	9-3/4	44-1/16	44-1/16	63-7/8	63-9/16	3/8	11-3/4	12-3/16	71-1/2	9	11	5/8	109	129
C5-35U-30	C6-35U-30	30	39	8-7/16	8-15/16	15-1/16	15	30-3/4	30-3/16	5/16	13-11/16	14-1/16	41	6	9-1/2	5/8	58	70
C5-35U-36	C6-35U-36	36	45	8-7/16	8-15/16	21-1/16	12	36-3/4	36-3/16	5/16	13-11/16	14-1/16	47	6	9-1/2	5/8	65	79
C5-35U-42	C6-35U-42	42	51	8-13/16	9-5/16	26-9/16	26-9/16	42-7/8	42-3/8	5/16	13-3/4	14-3/16	53	7-1/2	9-1/2	5/8	80	94
C5-35U-48	C6-35U-48	48	57	8-13/16	9-5/16	32-9/16	32-9/16	48-7/8	48-3/8	5/16	13-3/4	14-3/16	59	7-1/2	9-1/2	5/8	87	104
C5-35U-54	C6-35U-54	54	63	9-1/4	9-3/4	38-1/16	38-1/16	54-15/16	54-1/2	3/8	13-15/16	14-5/16	65-1/2	9	11	5/8	103	121
C5-35U-60	C6-35U-60	60	69	9-1/4	9-3/4	44-1/16	44-1/16	60-15/16	60-1/2	3/8	13-15/16	14-5/16	71-1/2	9	11	5/8	111	131
C5-45U-30	C6-45U-30	30	39	8-7/16	8-15/16	15-1/16	15	28-7/8	28-1/4	5/16	15	15-5/16	41	6	9-1/2	5/8	60	72
C5-45U-36	C6-45U-36	36	45	8-7/16	8-15/16	21-1/16	21	34-7/8	34-1/4	5/16	15	15-5/16	47	6	9-1/2	5/8	66	80
C5-45U-42	C6-45U-42	42	51	8-13/16	9-5/16	26-5/16	26-5/16	41	40-3/8	5/16	15-1/8	15-7/16	53	7-1/2	9-1/2	5/8	81	96
C5-45U-48	C6-45U-48	48	57	8-13/16	9-5/16	32-5/16	32-5/16	47	46-3/8	5/16	15-1/8	15-7/16	59	7-1/2	9-1/2	5/8	89	105
C5-45U-54	C6-45U-54	54	63	9-1/4	9-3/4	37-5/8	37-5/8	53-1/16	52-1/2	3/8	15-1/4	15-9/16	65-1/2	9	11	5/8	104	122
C5-45U-60	C6-45U-60	60	69	9-1/4	9-3/4	43-5/8	43-5/8	59-1/16	58-1/2	3/8	15-1/4	15-9/16	71-1/2	9	11	5/8	112	132

20°

35°

45°

* Recommended Bolt Pattern - See page 75 for minimum and maximum dimensions.

CEMA C IDLERS

OFFSET CENTER ROLL IDLER – 4" DIAMETER

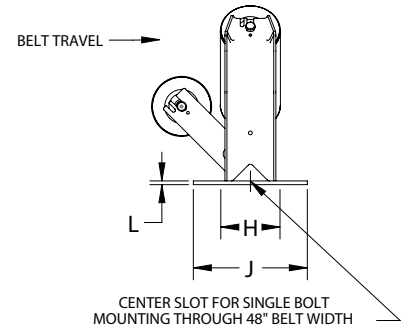
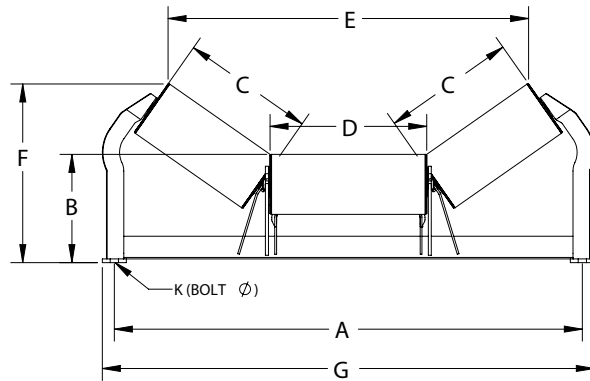

	4" PART NUMBER	BW	A	B	C	D	E	F	G	H*	J	K	L	WT (#)
20°	C4-20GO-24	24	33	7-7/8	9	11	27-15/16	11-1/8	35	6	9-1/2	5/8	5/16	43
	C4-20GO-30	30	39	7-7/8	11	13	33-11/16	11-13/16	41	6	9-1/2	5/8	5/16	52
	C4-20GO-36	36	45	7-7/8	13	15	39-7/16	12-1/2	47	6	9-1/2	5/8	5/16	57
	C4-20GO-42	42	51	8-5/16	15	17	45-3/16	13-9/16	53	7-1/2	9-1/2	5/8	5/16	72
	C4-20GO-48	48	57	8-5/16	17	19	51	14-1/4	59	7-1/2	9-1/2	5/8	5/16	78
	C4-20GO-54	54	63	8-11/16	19	21	56-3/4	15-5/16	65-1/2	9	11	5/8	3/8	94
	C4-20GO-60	60	69	8-11/16	21	23-5/16	62-1/2	16	71-1/2	9	11	5/8	3/8	101
35°	C4-35GO-24	24	33	7-15/16	9	11	25-5/16	13-5/16	35	6	9-1/2	5/8	5/16	45
	C4-35GO-30	30	39	7-15/16	11	13	30-9/16	14-7/16	41	6	9-1/2	5/8	5/16	54
	C4-35GO-36	36	45	7-15/16	13	15	35-7/8	15-5/8	47	6	9-1/2	5/8	5/16	60
	C4-35GO-42	42	51	8	15	17	41-1/8	17-1/8	53	7-1/2	9-1/2	5/8	5/16	75
	C4-35GO-48	48	57	8	17	19	46-3/8	18-5/16	59	7-1/2	9-1/2	5/8	5/16	82
	C4-35GO-54	54	63	8-7/16	19	21	51-11/16	19-7/8	65-1/2	9	11	5/8	3/8	97
	C4-35GO-60	60	69	8-7/16	21	23-5/16	56-15/16	21	71-1/2	9	11	5/8	3/8	105
45°	C4-45GO-30	30	39	8-11/16	11	13	28-7/16	16-1/16	41	6	9-1/2	5/8	5/16	56
	C4-45GO-36	36	45	9-1/16	13	15	33-1/4	17-1/2	47	6	9-1/2	5/8	5/16	62
	C4-45GO-42	42	51	9-1/16	15	17	38-1/16	19-5/16	53	7-1/2	9-1/2	5/8	5/16	77
	C4-45GO-48	48	57	9-1/16	17	19	42-15/16	20-11/16	59	7-1/2	9-1/2	5/8	5/16	84
	C4-45GO-54	54	63	9-1/2	19	21	47-3/4	22-1/2	65-1/2	9	11	5/8	3/8	100
	C4-45GO-60	60	69	9-1/2	21	23-5/16	52-9/16	23-15/16	71-1/2	9	11	5/8	3/8	108

CEMA C

* Recommended Bolt Pattern - See page 73 for minimum and maximum dimensions.

CEMA C IDLERS

OFFSET CENTER ROLL IDLER – 5" & 6" DIAMETER

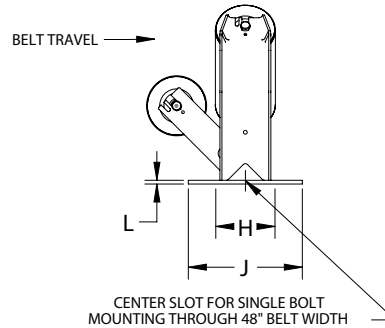
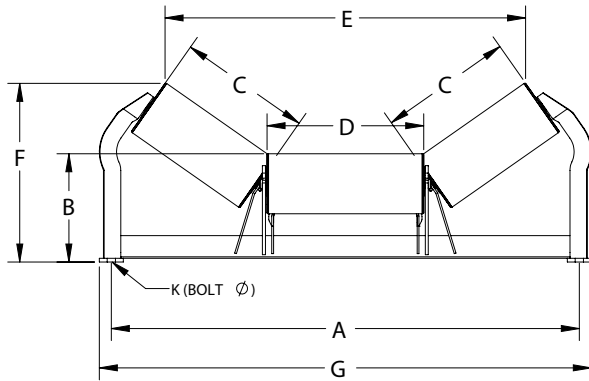

CEMA C

PART NUMBER		BW	A	B		C		D		E		F		G	H*	J	K	L	WT (#)	
5"	6"			5"	6"	5"	6"	5"	6"	5"	6"	5"	6"						5"	6"
C5-20GO-18	C6-20GO-18	18	27	8-1/4	8-3/4	7-1/16	7	9-1/16	9	21-7/8	21-9/16	10-3/4	11-1/4	29	6	8	5/8	5/16	43	52
C5-20GO-24	C6-20GO-24	24	33	8-3/8	8-7/8	9-1/16	9	11-1/16	11	27-5/16	27-5/16	11-9/16	12-1/16	35	6	9-1/2	5/8	5/16	51	62
C5-20GO-30	C6-20GO-30	30	39	8-3/8	8-7/8	11-1/16	11	13-1/16	13	33-7/16	33-1/16	12-5/16	12-3/4	41	6	9-1/2	5/8	5/16	61	73
C5-20GO-36	C6-20GO-36	36	45	8-3/8	8-7/8	13-1/16	13	15-1/16	15	39-3/16	38-7/8	12-15/16	13-7/16	47	6	9-1/2	5/8	5/16	68	83
C5-20GO-42	C6-20GO-42	42	51	8-13/16	9-5/16	15-1/16	15	17-1/16	17	44-15/16	44-5/8	14-1/16	14-1/2	53	7-1/2	9-1/2	5/8	5/16	83	100
C5-20GO-48	C6-20GO-48	48	57	8-13/16	9-5/16	17-1/16	17	19-1/16	19	50-11/16	50-3/8	14-3/4	15-3/16	59	7-1/2	9-1/2	5/8	5/16	92	110
C5-20GO-54	C6-20GO-54	54	63	9-3/16	9-11/16	19-1/16	19	21-1/16	21	56-7/16	56-1/8	15-13/16	16-5/16	65-1/2	9	11	5/8	3/8	108	129
C5-20GO-60	C6-20GO-60	60	69	9-3/16	9-11/16	21-1/16	21	23-3/8	23-3/8	62-3/16	61-7/8	16-1/2	17	71-1/2	9	11	5/8	3/8	117	139
C5-35GO-18	C6-35GO-18	18	27	8-7/8	8-13/16	7-1/16	7	9-1/16	9	19-1/2	18-15/16	12-7/16	12-13/16	29	6	8	1/2	3/16	45	53
C5-35GO-24	C6-35GO-24	24	33	9	8-15/16	9-1/16	9	11-1/16	11	24-3/4	24-1/4	13-11/16	14-1/8	35	6	9-1/2	5/8	5/16	53	64
C5-35GO-30	C6-35GO-30	30	39	9	8-15/16	11-1/16	11	13-1/16	13	30-1/16	29-1/2	14-7/8	15-1/4	41	6	9-1/2	5/8	5/16	63	76
C5-35GO-36	C6-35GO-36	36	45	9-9/16	8-15/16	13-1/16	13	15-1/16	15	35-5/16	34-13/16	16	16-7/16	47	6	9-1/2	5/8	5/16	71	85
C5-35GO-42	C6-35GO-42	42	51	9-1/16	9	15-1/16	15	17-1/16	17	40-5/8	40-1/16	17-9/16	17-15/16	53	7-1/2	9-1/2	5/8	5/16	86	103
C5-35GO-48	C6-35GO-48	48	57	9-1/16	9	17-1/16	17	19-1/16	19	45-7/8	45-3/8	18-11/16	19-1/8	59	7-1/2	9-1/2	5/8	5/16	97	113
C5-35GO-54	C6-35GO-54	54	63	9-7/16	9-7/16	19-1/16	19	21-1/16	21	51-1/8	50-5/8	20-1/4	20-11/16	65-1/2	9	11	5/8	3/8	112	132
C5-35GO-60	C6-35GO-60	60	69	9-7/16	9-7/16	21-1/16	21	23-3/8	23-3/8	56-7/16	55-7/8	21-7/16	21-13/16	71-1/2	9	11	5/8	3/8	115	143
C5-45GO-18	C6-45GO-18	18	27	9-1/16	9-9/16	7-1/16	7	9-1/16	9	18-1/16	17-7/16	13-1/2	13-3/4	29	6	9-1/2	5/8	5/16	46	54
C5-45GO-24	C6-45GO-24	24	33	9-3/16	9-11/16	9-1/16	9	11-1/16	11	22-7/8	22-1/4	15	15-5/16	35	6	9-1/2	5/8	5/16	54	65
C5-45GO-30	C6-45GO-30	30	39	9-3/16	9-11/16	11-1/16	11	13-1/16	13	27-3/4	27-1/8	16-7/16	16-3/4	41	6	9-1/2	5/8	5/16	65	77
C5-45GO-36	C6-45GO-36	36	45	9-3/16	9-11/16	13-1/16	13	15-1/16	15	32-9/16	31-15/16	17-7/8	18-3/16	47	6	9-1/2	5/8	5/16	72	87
C5-45GO-42	C6-45GO-42	42	51	9-9/16	10-1/16	15-1/16	15	17-1/16	17	37-7/16	36-3/4	19-5/8	19-15/16	53	7-1/2	9-1/2	5/8	5/16	89	105
C5-45GO-48	C6-45GO-48	48	57	9-9/16	10-1/16	17-1/16	17	19-1/16	19	42-1/4	41-5/8	21-1/16	21-3/8	59	7-1/2	9-1/2	5/8	5/16	97	116
C5-45GO-54	C6-45GO-54	54	63	10	10-1/2	19-1/16	19	21-1/16	21	47-1/16	46-7/16	22-7/8	23-3/16	65-1/2	9	11	5/8	3/8	115	135
C5-45GO-60	C6-45GO-60	60	69	10	10-1/2	21-1/16	21	23-3/8	23-3/8	51-7/8	51-1/4	24-5/16	25-5/8	71-1/2	9	11	5/8	3/8	124	146

20°

35°

45°

* Recommended Bolt Pattern - See page 75 for minimum and maximum dimensions.

CEMA C IDLERS

CHANNEL MOUNT – 4" & 5" DIAMETER

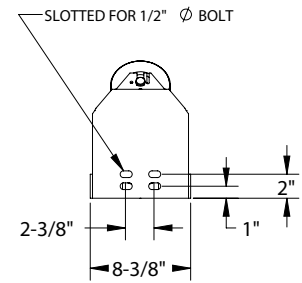
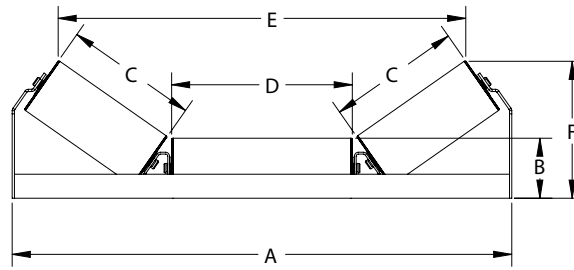

20°

35°

PART NUMBER		BW*	A	B		C		D		E		F		WT (#)	
4"	5"			4"	5"	4"	5"	4"	5"	4"	5"	4"	5"	4"	5"
C4-20CM-18	C5-20CM-18	18	23-5/8	4-1/2	5	6	6-1/16	7	7-1/16	20-3/16	19-15/16	6-11/16	7-1/8	33	38
C4-20CM-20	C5-20CM-20	20	25-5/8	4-1/2	5	7	7-1/16	7	7-1/16	23-3/16	21-7/8	7-1/16	7-1/2	35	41
C4-20CM-24	C5-20CM-24	24	29-5/8	4-1/2	5	7	7-1/16	11	11-1/16	26-1/16	25-3/4	7-1/16	7-1/2	39	46
C4-20CM-30	C5-20CM-30	30	35-5/8	4-1/2	5	9	9-1/16	13	13-1/16	31-13/16	31-9/16	7-11/16	8-3/16	46	54
C4-20CM-36	C5-20CM-36	36	41-5/8	4-1/2	5	11	11-1/16	15	15-1/16	37-9/16	37-5/16	8-3/8	8-7/8	52	62
C4-20CM-42	C5-20CM-42	42	47-5/8	4-1/2	5	13	13-1/16	17	17-1/16	43-5/16	43-1/16	9-1/16	9-9/16	59	70
C4-20CM-48	C5-20CM-48	48	53-5/8	4-1/2	5	15	15-1/16	19	19-1/16	49-1/16	48-13/16	9-3/4	10-3/16	65	78
C4-20CM-54	C5-20CM-54	54	59-5/8	4-1/2	5	17	17-1/16	21-5/16	21-3/8	55-1/8	54-13/16	10-3/8	10-7/8	80	94
C4-20CM-60	C5-20CM-60	60	65-5/8	4-1/2	5	19	19-1/16	23-5/16	23-3/8	60-7/8	60-5/8	11-1/8	11-9/16	88	103
C4-35CM-18	C5-35CM-18	18	23-5/8	4-1/2	5	6	6-1/16	7	7-1/16	18-5/16	17-3/4	8-1/8	8-9/16	37	42
C4-35CM-20	C5-35CM-20	20	25-5/8	4-1/2	5	7	7-1/16	7	7-1/16	19-15/16	19-7/16	8-11/16	9-1/8	40	46
C4-35CM-24	C5-35CM-24	24	29-5/8	4-1/2	5	7	7-1/16	11	11-1/16	23-15/16	23-7/16	8-11/16	9-1/8	44	51
C4-35CM-30	C5-35CM-30	30	35-5/8	4-1/2	5	9	9-1/16	13	13-1/16	29-3/16	28-11/16	9-7/8	10-1/4	51	59
C4-35CM-36	C5-35CM-36	36	41-5/8	4-1/2	5	11	11-1/16	15	15-1/16	34-1/2	33-15/16	11	11-7/16	57	67
C4-35CM-42	C5-35CM-42	42	47-5/8	4-1/2	5	13	13-1/16	17	17-1/16	39-3/4	39-3/16	12-1/8	12-9/16	64	75
C4-35CM-48	C5-35CM-48	48	53-5/8	4-1/2	5	15	15-1/16	19	19-1/16	45-1/16	44-1/2	13-5/16	13-3/4	71	84
C4-35CM-54	C5-35CM-54	54	59-5/8	4-1/2	5	17	17-1/16	21-5/16	21-3/8	50-5/8	50-1/8	14-7/16	14-7/8	87	101
C4-35CM-60	C5-35CM-60	60	65-5/8	4-1/2	5	19	19-1/16	23-5/16	23-3/8	55-13/16	55-5/16	15-9/16	16	95	110

CEMA C

* 6 -3/8" wide frame is available upon request.

CEMA C IDLERS

LOW PROFILE STANDARD MOUNT – 4" & 5" DIAMETER

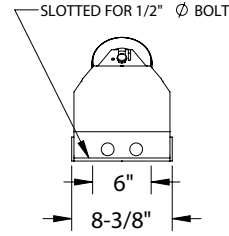
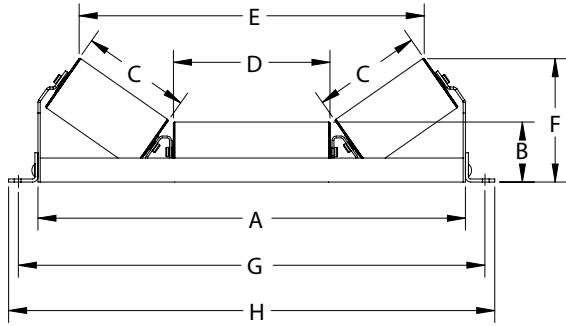

CEMA C

PART NUMBER		BW*	A	B		C		D		E		F		G	H	WT (#)	
4"	5"			4"	5"	4"	5"	4"	5"	4"	5"	4"	5"			4"	5"
C4-20SM-18	C5-20SM-18	18	23-5/8	4-1/2	5	6	6-1/16	7	7-1/16	20-1/4	19-15/16	6-11/16	7-3/16	27	28-1/2	38	43
C4-20SM-20	C5-20SM-20	20	25-5/8	4-1/2	5	7	7-1/16	7	7-1/16	22-1/4	21-15/16	7-1/16	7-1/2	29	30-1/2	40	45
C4-20SM-24	C5-20SM-24	24	29-5/8	4-1/2	5	7	7-1/16	11	11-1/16	26-1/8	25-7/8	7	7-1/2	33	34-1/2	44	50
C4-20SM-30	C5-20SM-30	30	35-5/8	4-1/2	5	9	9-1/16	13	13-1/16	37-7/8	31-5/8	7-11/16	8-3/16	39	40-1/2	51	59
C4-20SM-36	C5-20SM-36	36	41-5/8	4-1/2	5	11	11-1/16	15	15-1/16	37-5/8	37-3/8	8-3/8	8-7/8	45	46-1/2	57	67
C4-20SM-42	C5-20SM-42	42	47-5/8	4-1/2	5	13	13-1/16	17	17-1/16	43-7/16	43-1/8	9-1/16	9-9/16	51	52-1/2	64	75
C4-20SM-48	C5-20SM-48	48	53-5/8	4-1/2	5	15	15-1/16	19	19-1/16	49-3/16	48-7/8	9-3/4	10-1/4	57	58-1/2	70	83
C4-20SM-54	C5-20SM-54	54	59-5/8	4-1/2	5	17	17-1/16	21-5/16	21-3/8	55-3/16	54-15/16	10-7/16	10-7/8	63	64-1/2	85	99
C4-20SM-60	C5-20SM-60	60	65-5/8	4-1/2	5	19	19-1/16	23-5/16	21-3/8	60-15/16	60-5/8	11-1/8	11-5/8	69	70-1/2	93	108
C4-35SM-18	C5-35SM-18	18	23-5/8	4-1/2	5	6	6-1/16	7	7-1/16	18-3/8	17-13/16	8-1/8	8-9/16	27	28-1/2	42	47
C4-35SM-20	C5-35SM-20	20	25-5/8	4-1/2	5	7	7-1/16	7	7-1/16	20	19-1/2	8-3/4	9-1/8	29	30-1/2	44	51
C4-35SM-24	C5-35SM-24	24	29-5/8	4-1/2	5	7	7-1/16	11	11-1/16	24	23-1/2	8-3/4	9-1/8	33	34-1/2	49	55
C4-35SM-30	C5-35SM-30	30	35-5/8	4-1/2	5	9	9-1/16	13	13-1/16	29-1/4	28-3/4	9-7/8	10-1/4	39	40-1/2	56	64
C4-35SM-36	C5-35SM-36	36	41-5/8	4-1/2	5	11	11-1/16	15	15-1/16	34-9/16	34	11	11-7/16	45	46-1/2	63	72
C4-35SM-42	C5-35SM-42	42	47-5/8	4-1/2	5	13	13-1/16	17	17-1/16	39-13/16	39-1/4	12-3/16	12-9/16	51	52-1/2	69	80
C4-35SM-48	C5-35SM-48	48	53-5/8	4-1/2	5	15	15-1/16	19	19-1/16	45-1/16	44-9/16	13-5/16	13-3/4	57	58-1/2	76	89
C4-35SM-54	C5-35SM-54	54	59-5/8	4-1/2	5	17	17-1/16	21-5/16	21-3/8	50-11/16	50-3/16	14-7/16	14-7/8	63	64-1/2	92	106
C4-35SM-60	C5-35SM-60	60	65-5/8	4-1/2	5	19	19-1/16	23-5/16	21-3/8	55-15/16	55-3/8	15-5/8	16	69	70-1/2	100	115

20°

35°

* 6 -3/8" wide frame is available upon request.

CEMA C IDLERS

CHANNEL MOUNT IMPACT IDLERS

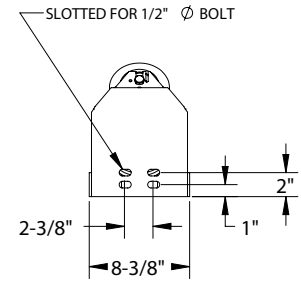
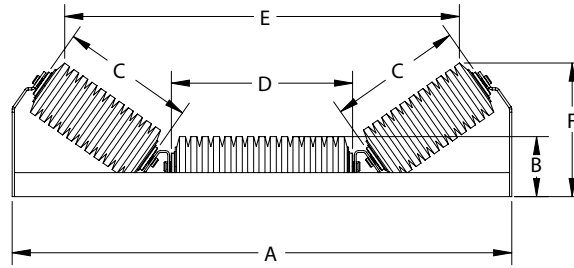

	PART NUMBER		BW	A	B		C	D	E		F		WT (#)	
	4"	5"			4"	5"			4"	5"	4"	5"	4"	5"
20°	C4-20CMI-18	C5-20CMI-18	18	23-5/8	4-1/2	5	6-1/8	7-1/8	20-15/16	15-5/8	6-1/2	7	34	39
	C4-20CMI-20	C5-20CMI-20	20	25-5/8	4-1/2	5	7-1/8	7-1/8	20-15/16	20-5/8	6-13/16	7-3/8	38	42
	C4-20CMI-24	C5-20CMI-24	24	29-5/8	4-1/2	5	7-1/8	11-1/8	24-13/16	24-9/16	6-13/16	7-5/16	43	48
	C4-20CMI-30	C5-20CMI-30	30	35-5/8	4-1/2	5	9-1/8	13-1/8	30-9/16	30-5/16	7-1/2	8	51	58
	C4-20CMI-36	C5-20CMI-36	36	41-5/8	4-1/2	5	11-1/8	15-1/8	36-3/8	36-1/16	8-3/16	8-11/16	59	67
	C4-20CMI-42	C5-20CMI-42	42	47-5/8	4-1/2	5	13-1/8	17-1/8	41-5/8	41-7/8	8-7/8	9-3/8	67	76
	C4-20CMI-48	C5-20CMI-48	48	53-5/8	4-1/2	5	15-1/8	19-1/8	47-7/8	47-5/8	9-9/16	10-1/16	76	86
	C4-20CMI-54	C5-20CMI-54	54	59-5/8	4-1/2	5	17-1/8	21-7/16	53-7/8	53-5/8	10-1/4	10-11/16	93	104
	C4-20CMI-60	C5-20CMI-60	60	65-5/8	4-1/2	5	19-1/8	23-7/16	61	59-3/8	10-15/16	11-7/16	102	115
	35°	C4-35CMI-18	C5-35CMI-18	18	23-5/8	4-1/2	5	6-1/8	7-1/8	17-3/16	16-11/16	7-13/16	8-1/4	39
C4-35CMI-20		C5-35CMI-20	20	25-5/8	4-1/2	5	7-1/8	7-1/8	18-7/8	18-5/16	8-3/8	8-13/16	42	47
C4-35CMI-24		C5-35CMI-24	24	29-5/8	4-1/2	5	7-1/8	11-1/8	25-1/8	22-5/16	8-3/8	8-13/16	47	53
C4-35CMI-30		C5-35CMI-30	30	35-5/8	4-1/2	5	9-1/8	13-1/8	28-1/8	27-5/8	9-9/16	10	56	62
C4-35CMI-36		C5-35CMI-36	36	41-5/8	4-1/2	5	11-1/8	15-1/8	33-3/8	32-7/8	10-13/16	11-1/8	65	72
C4-35CMI-42		C5-35CMI-42	42	47-5/8	4-1/2	5	13-1/8	17-1/8	38-5/8	38-1/8	11-7/8	12-5/16	73	82
C4-35CMI-48		C5-35CMI-48	48	53-5/8	4-1/2	5	15-1/8	19-1/8	43-15/16	43-7/16	13	13-7/16	82	92
C4-35CMI-54		C5-35CMI-54	54	59-5/8	4-1/2	5	17-1/8	21-7/16	49-1/2	49	14-1/8	14-9/16	99	111
C4-35CMI-60		C5-35CMI-60	60	65-5/8	4-1/2	5	19-1/8	23-7/16	54-3/4	54-1/4	15-1/4	15-11/16	109	122

CEMA D IDLERS

TROUGHING IDLERS (EQUAL LENGTH ROLLERS) – 5" & 6" DIAMETER

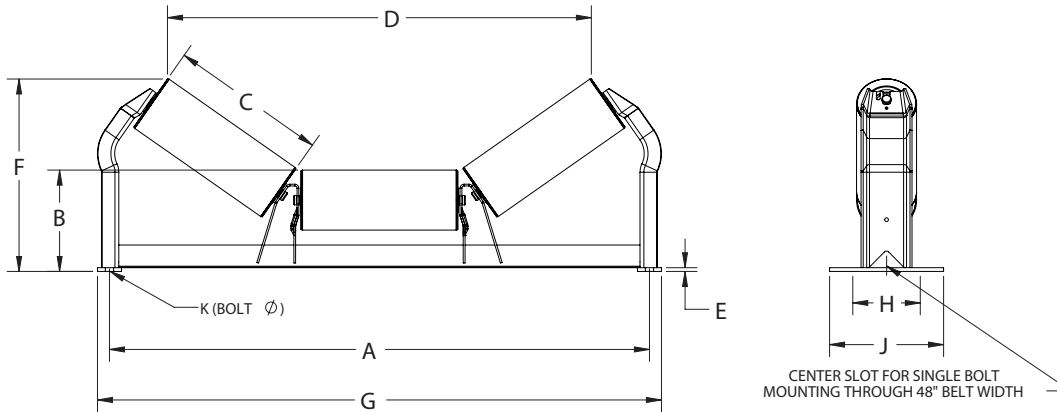

PART NUMBER*		BW	A	B		C	D		E	F		G	H**	J	K	WT (#)	
5"	6"			5"	6"		5"	6"		5"	6"					5"	6"
D5-20E-24	D6-20E-24	24	33	8-1/2	9	9-1/16	27-11/16	27-5/16	5/16	11-11/16	12-1/8	35	6	9-1/2	5/8	54	64
D5-20E-30	D6-20E-30	30	39	8-1/2	9	11-1/16	33-7/16	33-1/8	5/16	12-3/8	12-13/16	41	6	9-1/2	5/8	64	76
D5-20E-36	D6-20E-36	36	45	8-1/2	9	13-1/16	39-3/16	38-7/8	5/16	13-1/16	13-1/2	47	6	9-1/2	5/8	71	86
D5-20E-42	D6-20E-42	42	51	8-7/8	9-3/8	15-1/16	44-15/16	44-5/8	5/16	14-1/8	14-5/8	53	7-1/2	9-1/2	5/8	87	104
D5-20E-48	D6-20E-48	48	57	9-1/4	9-3/4	17-1/16	51	50-11/16	5/16	14-7/8	15-5/16	59	7-1/2	9-1/2	5/8	101	119
D5-20E-54	D6-20E-54	54	63	9-5/16	9-13/16	19-1/16	56-1/2	56-1/8	3/8	15-15/16	16-3/8	65-1/2	9	11	5/8	113	133
D5-20E-60	D6-20E-60	60	69	9-5/16	9-13/16	21-1/16	62-1/4	61-7/8	3/8	16-5/8	17-1/16	71-1/2	9	11	5/8	122	144
D5-20E-72	D6-20E-72	72	81	9-5/16	9-13/16	25-1/16	73-3/4	73-3/8	3/8	18	18-7/16	83-1/2	9	11	5/8	140	166
D5-35E-24	D6-35E-24	24	33	8-1/2	9	9-1/16	24-3/4	24-3/16	5/16	13-3/4	14-3/16	35	6	9-1/2	5/8	56	66
D5-35E-30	D6-35E-30	30	39	8-1/2	9	11-1/16	30	29-7/16	5/16	14-15/16	15-3/8	41	6	9-1/2	5/8	66	78
D5-35E-36	D6-35E-36	36	45	8-1/2	9	13-1/16	35-5/16	34-3/4	5/16	16-1/8	16-1/2	47	6	9-1/2	5/8	74	88
D5-35E-42	D6-35E-42	42	51	8-7/8	9-3/8	15-1/16	40-9/16	40	5/16	17-5/8	18-1/16	53	7-1/2	9-1/2	5/8	90	107
D5-35E-48	D6-35E-48	48	57	9-1/4	9-3/4	17-1/16	46-1/4	45-11/16	5/16	18-15/16	19-5/16	59	7-1/2	9-1/2	5/8	104	122
D5-35E-54	D6-35E-54	54	63	9-5/16	9-13/16	19-1/16	51-1/8	50-9/16	3/8	20-3/8	20-3/4	65-1/2	9	11	5/8	117	137
D5-35E-60	D6-35E-60	60	69	9-5/16	9-13/16	21-1/16	56-7/16	55-13/16	3/8	21-1/2	21-7/8	71-1/2	9	11	5/8	126	148
D5-35E-72	D6-35E-72	72	81	9-5/16	9-13/16	25-1/16	66-15/16	66-3/8	3/8	23-13/16	24-3/16	83-1/2	9	11	5/8	145	171
D5-45E-24	D6-45E-24	24	33	8-1/2	9	9-1/16	22-13/16	22-1/8	5/16	15-1/16	15-3/8	35	6	9-1/2	5/8	57	67
D5-45E-30	D6-45E-30	30	39	8-1/2	9	11-1/16	27-11/16	27	5/16	16-1/2	16-13/16	41	6	9-1/2	5/8	68	80
D5-45E-36	D6-45E-36	36	45	8-1/2	9	13-1/16	32-1/2	31-3/16	5/16	17-15/16	18-1/4	47	6	9-1/2	5/8	76	90
D5-45E-42	D6-45E-42	42	51	8-7/8	9-3/8	15-1/16	37-3/8	36-11/16	5/16	19-11/16	20-1/16	53	7-1/2	9-1/2	5/8	92	109
D5-45E-48	D6-45E-48	48	57	9-1/4	9-3/4	17-1/16	42-9/16	41-7/8	5/16	21-5/16	21-5/8	59	7-1/2	9-1/2	5/8	106	125
D5-45E-54	D6-45E-54	54	63	9-5/16	9-13/16	19-1/16	47	46-5/16	3/8	22-15/16	23-5/16	65-1/2	9	11	5/8	119	139
D5-45E-60	D6-45E-60	60	69	9-5/16	9-13/16	21-1/16	51-7/8	51-3/16	3/8	24-3/8	24-11/16	71-1/2	9	11	5/8	129	151
D5-45E-72	D6-45E-72	72	81	9-5/16	9-13/16	25-1/16	61-1/2	60-13/16	3/8	27-3/16	27-9/16	83-1/2	9	11	5/8	148	174

20°

35°

45°

*Add MOX to the end of the part number to replace steel cans with Moxie Rolls.

** Recommended Bolt Pattern - See page 75 for minimum and maximum dimensions.

CEMA D IDLERS

RETURN IDLERS – 5" & 6" DIAMETER

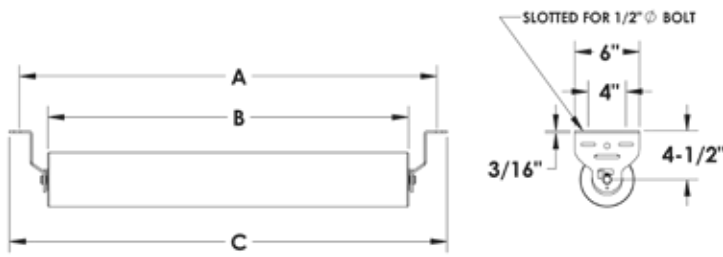

PART NUMBER*		BW	A	B	C	WT (#)**	
5"	6"					5"	6"
D5-RET-18	D6-RET-18	18	27	21-3/8	28-7/16	25	33
D5-RET-20	D6-RET-20	20	29	23-3/8	30-7/16	27	34
D5-RET-24	D6-RET-24	24	33	27-3/8	34-7/16	30	40
D5-RET-30	D6-RET-30	30	39	33-3/8	40-7/16	36	47
D5-RET-36	D6-RET-36	36	45	39-3/8	46-7/16	41	54
D5-RET-42	D6-RET-42	42	51	45-3/8	52-7/16	46	61
D5-RET-48	D6-RET-48	48	57	51-3/8	58-7/16	51	68
D5-RET-54	D6-RET-54	54	63	57-3/8	64-7/16	56	76
D5-RET-60	D6-RET-60	60	69	63-3/8	70-7/16	61	83
D5-RET-72	D6-RET-72	72	81	75-3/8	82-7/16	72	97

FLAT IDLERS – 5" & 6" DIAMETER

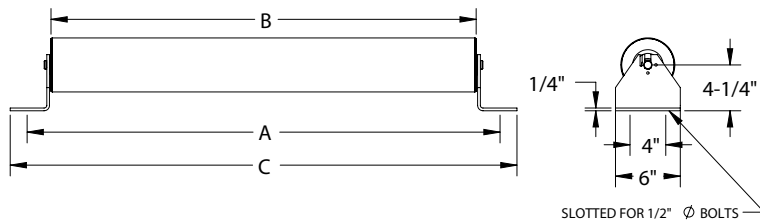

PART NUMBER		BW	A	B	C	WT (#)**	
5"	6"					5"	6"
D5-FLT-18	D6-FLT-18	18	27	21-3/8	28-15/16	28	37
D5-FLT-20	D6-FLT-20	20	29	23-3/8	30-15/16	30	37
D5-FLT-24	D6-FLT-24	24	33	27-3/8	34-15/16	33	43
D5-FLT-30	D6-FLT-30	30	39	33-3/8	40-15/16	38	50
D5-FLT-36	D6-FLT-36	36	45	39-3/8	46-15/16	43	57
D5-FLT-42	D6-FLT-42	42	51	45-3/8	52-15/16	49	64
D5-FLT-48	D6-FLT-48	48	57	51-3/8	58-15/16	54	71
D5-FLT-54	D6-FLT-54	54	63	57-3/8	64-15/16	59	78
D5-FLT-60	D6-FLT-60	60	69	63-3/8	70-15/16	64	85
D5-FLT-72	D6-FLT-72	72	81	75-3/8	82-15/16	74	99

V-RETURN IDLER – 5" & 6" DIAMETER

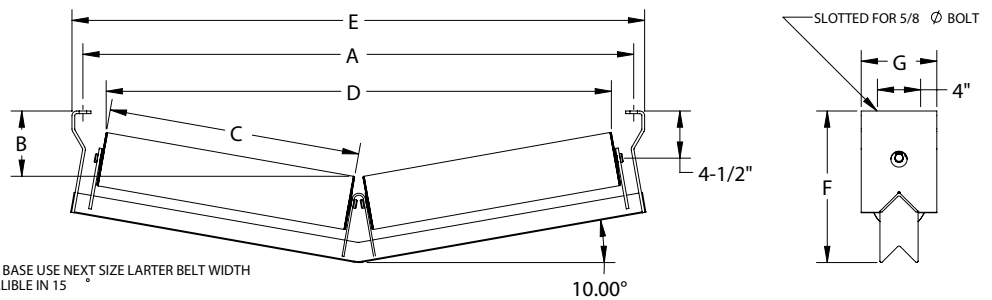

FOR WIDE BASE USE NEXT SIZE LARGER BELT WIDTH
ALSO AVAILABLE IN 15°

PART NUMBERS		BW	A	B		C	D		E	F	G	WT (#)	
5"	6"			5"	6"		5"	6"				5"	6"
D5-10RETV-24	D6-10RETV-24	24	33	4-3/8	3-7/8	14-3/8	29	28-9/16	35-1/8	12-3/8	9-1/2	58	68
D5-10RETV-30	D6-10RETV-30	30	39	4-7/8	4-3/8	17	34-5/16	33-7/8	41-1/8	12-7/8	9-1/2	64	76
D5-10RETV-36	D6-10RETV-36	36	45	5-7/16	4-15/16	20-1/2	41-1/16	40-5/8	47-1/8	13-3/8	9-1/2	71	86
D5-10RETV-42	D6-10RETV-42	42	51	5-15/16	5-7/16	23-3/8	46-11/16	46-1/4	53-1/8	14	9-1/2	78	92
D5-10RETV-48	D6-10RETV-48	48	57	6-7/16	6	26-1/2	53	52-9/16	59-1/8	14-1/2	9-1/2	85	103
D5-10RETV-54	D6-10RETV-54	54	63	7	6-1/2	29-1/4	58-5/16	57-7/8	65-1/8	15-3/8	9-1/2	107	127
D5-10RETV-60	D6-10RETV-60	60	69	7-1/2	7-1/16	32-1/2	64-13/16	64-3/8	71-1/8	15-7/8	9-1/2	116	138
D5-10RETV-66	D6-10RETV-66	66	75	8-1/16	7-9/16	35-3/4	71-1/8	70-11/16	77-1/8	16-3/8	9-1/2	125	149
D5-10RETV-72	D6-10RETV-72	72	81	8-9/16	8-1/16	38	75-5/8	75-3/16	83-1/8	17	9-1/2	132	157
D5-10RETV-78	D6-10RETV-78	78	87	9-1/8	8-5/8	41-1/4	82	81-9/16	89-1/8	17-1/2	9 1/2	140	164

*Add MOX to the end of the part number to replace steel cans with Moxie Rolls.

** All weights include brackets, individual bracket weights are listed on page 73 and 74. Brackets are sold separately.

CEMA D IDLERS

RUBBER CUSHION IMPACT TROUGHING IDLER – 5" & 6" DIAMETER

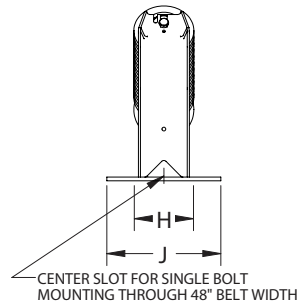
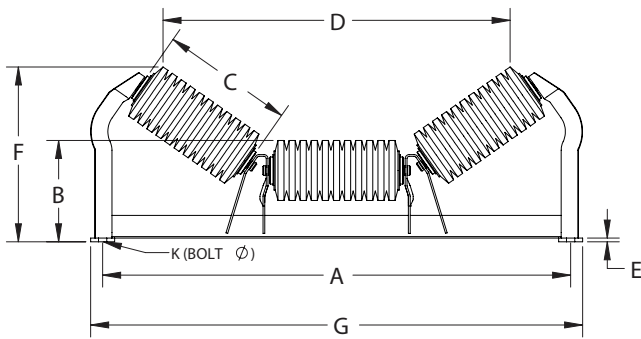

PART NUMBER		BW*	A	B		C	D		E	F		G	H**	J	K	WT (#)	
5"	6"			5"	6"		5"	6"		5"	6"					5"	6"
D5-20EI-24	D6-20EI-24	24	33	8-1/2	9	9-1/8	26-5/16	25-15/16	5/16	11-1/2	11-15/16	35	6	9-1/2	5/8	61	68
D5-20EI-30	D6-20EI-30	30	39	8-1/2	9	11-1/8	32-1/8	31-3/4	5/16	12-3/16	12-11/16	41	6	9-1/2	5/8	74	82
D5-20EI-36	D6-20EI-36	36	45	8-1/2	9	13-1/8	37-7/8	37-1/2	5/16	12-7/8	13-3/8	47	6	9-1/2	5/8	92	94
D5-20EI-42	D6-20EI-42	42	51	8-7/8	9-3/8	15-1/8	43-5/8	43-1/4	5/16	13-15/16	14-7/16	53	7-1/2	9-1/2	5/8	112	123
D5-20EI-48	D6-20EI-48	48	57	9-1/4	9-3/4	17-1/8	49-11/16	49-5/16	5/16	14-11/16	15-3/16	59	7-1/2	9-1/2	5/8	129	141
D5-20EI-54	D6-20EI-54	54	63	9-5/16	9-13/16	19-1/8	55-1/8	54-3/4	3/8	15-3/4	16-3/16	65-1/2	9	11	5/8	146	160
D5-20EI-60	D6-20EI-60	60	69	9-5/16	9-13/16	21-1/8	60-7/8	60-1/2	3/8	16-7/16	16-7/8	71-1/2	9	11	5/8	159	175
D5-20EI-72	D6-20EI-72	72	81	9-5/16	9-13/16	25-1/8	72-3/8	72	3/8	17-13/16	18-1/4	83-1/2	9	11	5/8	183	202
D5-35EI-24	D6-35EI-24	24	33	8-1/2	9	9-1/8	23-1/2	22-15/16	5/16	13-7/16	13-7/8	35	6	9-1/2	5/8	63	70
D5-35EI-30	D6-35EI-30	30	39	8-1/2	9	11-1/8	28-13/16	28-3/16	5/16	14-5/8	15-1/16	41	6	9-1/2	5/8	76	85
D5-35EI-36	D6-35EI-36	36	45	8-1/2	9	13-1/8	34-1/16	33-1/2	5/16	15-13/16	16-3/16	47	6	9-1/2	5/8	95	97
D5-35EI-42	D6-35EI-42	42	51	8-7/8	9-3/8	15-1/8	39-5/16	38-3/4	5/16	17-5/16	17-3/4	53	7-1/2	9-1/2	5/8	116	127
D5-35EI-48	D6-35EI-48	48	57	9-1/4	9-3/4	17-1/8	44-15/16	44-7/16	5/16	18-5/8	19	59	7-1/2	9-1/2	5/8	132	145
D5-35EI-54	D6-35EI-54	54	63	9-5/16	9-13/16	19-1/8	49-7/8	49-5/16	3/8	20	20-7/16	65-1/2	9	11	5/8	150	165
D5-35EI-60	D6-35EI-60	60	69	9-5/16	9-13/16	21-1/8	55-1/8	54-9/16	3/8	21-3/16	21-9/16	71-1/2	9	11	5/8	163	179
D5-35EI-72	D6-35EI-72	72	81	9-5/16	9-13/16	25-1/8	65-11/16	65-1/8	3/8	23-1/2	23-7/8	83-1/2	9	11	5/8	188	207
D5-45EI-24	D6-45EI-24	24	33	8-1/2	9	9-1/8	21-11/16	21	5/16	14-5/8	15	35	6	9-1/2	5/8	64	71
D5-45EI-30	D6-45EI-30	30	39	8-1/2	9	11-1/8	26-9/16	25-7/8	5/16	16-1/16	16-7/16	41	6	9-1/2	5/8	78	86
D5-45EI-36	D6-45EI-36	36	45	8-1/2	9	13-1/8	31-7/16	30-11/16	5/16	17-1/2	17-7/16	47	6	9-1/2	5/8	97	99
D5-45EI-42	D6-45EI-42	42	51	8-7/8	9-3/8	15-1/8	36-3/16	35-1/2	5/16	19-5/16	16-5/8	53	7-1/2	9-1/2	5/8	118	129
D5-45EI-48	D6-45EI-48	48	57	9-1/4	9-3/4	17-1/8	41-7/16	40-3/4	5/16	20-15/16	21-1/4	59	7-1/2	9-1/2	5/8	135	148
D5-45EI-54	D6-45EI-54	54	63	9-5/16	9-13/16	19-1/8	45-7/8	45-3/16	3/8	22-9/16	22-7/8	65-1/2	9	11	5/8	152	167
D5-45EI-60	D6-45EI-60	60	69	9-5/16	9-13/16	21-1/8	50-11/16	50	3/8	23-15/16	24-5/16	71-1/2	9	11	5/8	166	183
D5-45EI-72	D6-45EI-72	72	81	9-5/16	9-13/16	25-1/8	60-3/8	59-5/8	3/8	26-13/16	27-1/8	83-1/2	9	11	5/8	191	211

20°

35°

45°

* Belt Width (Reinforcing on 36" BW - 72" BW Impact Frame only).

** Recommended Bolt Pattern - See page 75 for minimum and maximum dimensions.

CEMA D IDLERS

RUBBER CUSHION RETURN IDLERS –5” & 6” DIAMETER

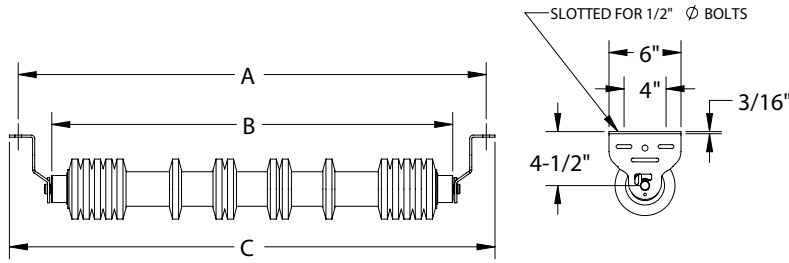

PART NUMBERS		BW	A	B	C	WT (#)*	
5"	6"					5"	6"
D5-RETI-18	D6-RETI-18	18	27	21-7/16	28-7/16	31	34
D5-RETI-20	D6-RETI-20	20	29	23-7/16	30-7/16	34	37
D5-RETI-24	D6-RETI-24	24	33	27-7/16	34-7/16	38	42
D5-RETI-30	D6-RETI-30	30	39	33-7/16	40-7/16	45	49
D5-RETI-36	D6-RETI-36	36	45	39-7/16	46-7/16	52	57
D5-RETI-42	D6-RETI-42	42	51	45-7/16	52-7/16	59	63
D5-RETI-48	D6-RETI-48	48	57	51-7/16	58-7/16	65	70
D5-RETI-54	D6-RETI-54	54	63	57-7/16	64-7/16	72	77
D5-RETI-60	D6-RETI-60	60	69	63-7/16	70-7/16	79	85
D5-RETI-72	D6-RETI-72	72	81	75-7/16	82-7/16	93	99

RUBBER CUSHION FLAT IDLERS –5” & 6” DIAMETER

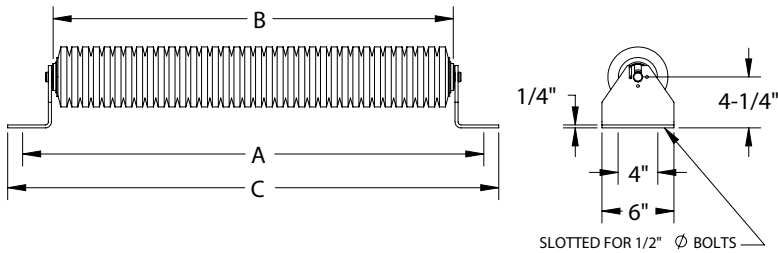

PART NUMBERS		BW	A	B	C	WT (#)*	
5"	6"					5"	6"
D5-FLTI-24	D6-FLTI-24	24	33	27-7/16	34-15/16	45	52
D5-FLTI-30	D6-FLTI-30	30	39	33-7/16	40-15/16	53	62
D5-FLTI-36	D6-FLTI-36	36	45	39-7/16	46-15/16	61	71
D5-FLTI-42	D6-FLTI-42	42	51	45-7/16	52-15/16	69	81
D5-FLTI-48	D6-FLTI-48	48	57	51-7/16	58-15/16	78	92
D5-FLTI-54	D6-FLTI-54	54	63	57-7/16	64-15/16	86	101
D5-FLTI-60	D6-FLTI-60	60	69	63-7/16	70-15/16	94	111
D5-FLTI-72	D6-FLTI-72	72	81	75-7/16	82-15/16	111	131

URATHON® RETURN ROLLS – 6” DIAMETER

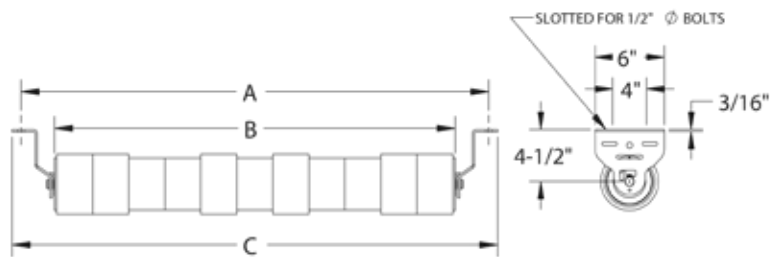

PART NUMBERS		BW	A	B	C	WT (#)*	
5"	6"					5"	6"
D5-RETU-18	D6-RETU-18	18	27	21-3/8	28-7/16	24	31
D5-RETU-24	D6-RETU-24	24	33	27-3/8	34-7/16	28	37
D5-RETU-30	D6-RETU-30	30	39	33-3/8	40-7/16	33	43
D5-RETU-36	D6-RETU-36	36	45	39-3/8	46-7/16	38	49
D5-RETU-42	D6-RETU-42	42	51	45-3/8	52-7/16	42	55
D5-RETU-48	D6-RETU-48	48	57	51-3/8	58-7/16	47	61
D5-RETU-54	D6-RETU-54	54	63	57-3/8	64-7/16	51	67
D5-RETU-60	D6-RETU-60	60	69	63-3/8	70-7/16	56	73
D5-RETU-72	D6-RETU-72	72	81	75-3/8	82-7/16	67	88

Note: Spiral Uraithon is only available in 6" diameter. To order Spiral Uraithon version add SP after RETU in the part number.

* All weights include brackets, individual bracket weights are listed on page 74 and 75. Brackets are sold separately.

CEMA D IDLERS

SELF-ALIGNING TROUGHING IDLERS – 5" & 6" DIAMETER

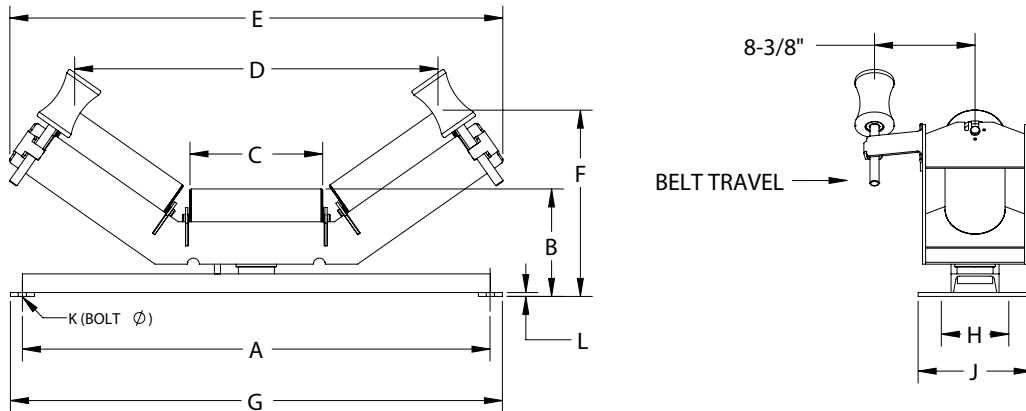

PART NUMBER		BW	A	B		C	D		E	F		G	H	J	K*	L	WT (#)	
5"	6"			5"	6"		5"	6"		5"	6"						5"	6"
D5-20EA-24	D6-20EA-24	24	33	9-1/8	9-5/8	9-1/16	28-9/16	28-1/4	36-3/4	12-7/16	12-15/16	35	6	9-1/2	5/8	5/16	104	115
D5-20EA-30	D6-20EA-30	30	39	9-1/8	9-5/8	11-1/16	34-5/16	34	42-9/16	13-1/8	13-5/8	41	6	9-1/2	5/8	5/16	127	139
D5-20EA-36	D6-20EA-36	36	45	9-1/8	9-5/8	13-1/16	40-1/16	39-3/4	48-5/16	13-13/16	14-5/16	47	6	9-1/2	5/8	5/16	140	154
D5-20EA-42	D6-20EA-42	42	51	9-5/8	10-1/8	15-1/16	45-11/16	45-5/16	54-3/16	15	15-5/16	53	6	9-1/2	5/8	5/16	157	173
D5-20EA-48	D6-20EA-48	48	57	9-5/8	10-1/8	17-1/16	51-7/16	51-1/16	60	15-11/16	16-1/8	59	6	9-1/2	5/8	5/16	170	189
D5-20EA-54	D6-20EA-54	54	63	9-11/16	10-3/16	19-1/16	57-3/16	56-13/16	65-3/4	18-7/16	16-7/8	65-1/2	6	9-1/2	5/8	3/8	186	207
D5-20EA-60	D6-20EA-60	60	69	9-11/16	10-3/16	21-1/16	62-15/16	62-5/8	71-1/2	17-1/8	17-7/16	71-1/2	9	11	5/8	3/8	200	222
D5-20EA-72	D6-20EA-72	72	81	9-11/16	10-3/16	25-1/16	74-1/2	74-7/16	83	18-1/2	18-15/16	83-1/2	9	11	5/8	3/8	227	252
D5-35EA-24	D6-35EA-24	24	33	9-1/8	9-5/8	9-1/16	24-15/16	24-3/8	35-5/8	14-1/2	14-15/16	35	6	9-1/2	5/8	5/16	105	115
D5-35EA-30	D6-35EA-30	30	39	9-1/8	9-5/8	11-1/16	30-3/16	29-5/8	40-15/16	15-11/16	16-1/16	41	6	9-1/2	5/8	5/16	127	140
D5-35EA-36	D6-35EA-36	36	45	9-1/8	9-5/8	13-1/16	35-1/2	34-15/16	46-3/16	16-13/16	17-1/16	47	6	9-1/2	5/8	5/16	140	155
D5-35EA-42	D6-35EA-42	42	51	9-5/8	10-1/8	15-1/16	40-7/16	39-7/8	51-3/4	18-7/16	18-11/16	53	6	9-1/2	5/8	5/16	157	174
D5-35EA-48	D6-35EA-48	48	57	9-5/8	10-1/8	17-1/16	45-3/4	45-1/8	57	19-7/16	20	59	6	9-1/2	5/8	5/16	171	189
D5-35EA-54	D6-35EA-54	54	63	9-11/16	10-3/16	19-1/16	51	50-7/16	62-1/4	20-13/16	21-1/16	65-1/2	6	9-1/2	5/8	3/8	187	207
D5-35EA-60	D6-35EA-60	60	69	9-11/16	10-3/16	21-1/16	56-1/4	55-11/16	67-9/16	21-15/16	22-3/16	71-1/2	9	11	5/8	3/8	201	223
D5-35EA-72	D6-35EA-72	72	81	9-11/16	10-3/16	25-1/16	66-13/16	66-1/4	78-1/8	24-1/4	24-5/8	83-1/2	9	11	5/8	3/8	228	254
D5-45EA-24	D6-45EA-24	24	33	9-1/8	9-5/8	9-1/16	23-1/2	22-13/16	35-1/2	15-1/2	15-13/16	35	6	9-1/2	5/8	5/16	106	117
D5-45EA-30	D6-45EA-30	30	39	9-1/8	9-5/8	11-1/16	28-5/16	27-5/8	40-5/16	17	17-5/16	41	6	9-1/2	5/8	5/16	128	141
D5-45EA-36	D6-45EA-36	36	45	9-1/8	9-5/8	13-1/16	33-1/8	32-7/16	45-3/16	18-7/16	18-3/4	47	6	9-1/2	5/8	5/16	142	156
D5-45EA-42	D6-45EA-42	42	51	9-5/8	10-1/8	15-1/16	37-9/16	36-7/8	50-5/16	20-5/16	20-1/2	53	6	9-1/2	5/8	5/16	159	175
D5-45EA-48	D6-45EA-48	48	57	9-5/8	10-1/8	17-1/16	42-3/8	41-11/16	55-1/8	21-3/4	21-15/16	59	6	9-1/2	5/8	5/16	172	191
D5-45EA-54	D6-45EA-54	54	63	9-11/16	10-3/16	19-1/16	47-3/16	46-1/2	59-15/16	23-3/16	23-7/16	65-1/2	6	9-1/2	5/8	3/8	189	209
D5-45EA-60	D6-45EA-60	60	69	9-11/16	10-3/16	21-1/16	52-1/16	51-3/8	64-3/4	24-1/2	24-15/16	71-1/2	9	11	5/8	3/8	202	224
D5-45EA-72	D6-45EA-72	72	81	9-11/16	10-3/16	25-1/16	61-11/16	61	74-7/16	27-7/16	27-13/16	83-1/2	9	11	5/8	3/8	229	255

20°

35°

45°

* Recommended Bolt Pattern - See page 75 for minimum and maximum dimensions.
 Note: Also available in bi-directional shoe-activated option. Designated by (BA).

CEMA D IDLERS

SELF-ALIGNING RETURN IDLERS – 5" & 6" DIAMETER**

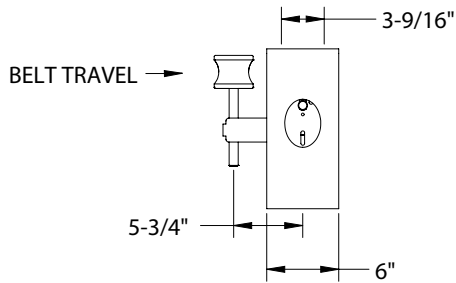
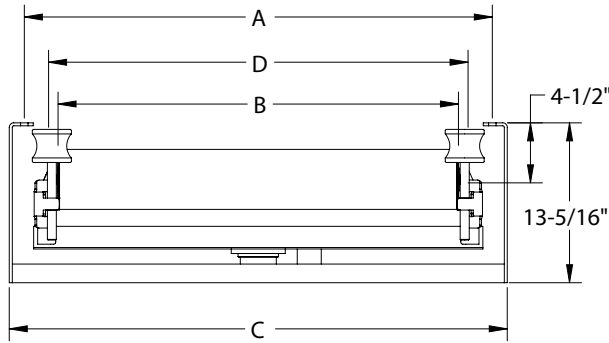

PART NUMBERS		BW	A	B	C	D	WT (#)	
5"	6"						5"	6"
D5-RETA-18	D6-RETA-18	18	27	21-3/8	29-1/2	25-5/8	72	80
D5-RETA-24	D6-RETA-24	24	33	27-3/8	35-1/2	31-5/8	81	91
D5-RETA-30	D6-RETA-30	30	39	33-3/8	41-1/2	37-5/8	94	105
D5-RETA-36	D6-RETA-36	36	45	39-3/8	47-1/2	43-5/8	104	117
D5-RETA-42	D6-RETA-42	42	51	45-3/8	53-1/2	49-5/8	122	137
D5-RETA-48	D6-RETA-48	48	57	51-3/8	59-1/2	55-5/8	133	150
D5-RETA-54	D6-RETA-54	54	63	57-3/8	65-1/2	61-5/8	144	163
D5-RETA-60	D6-RETA-60	60	69	63-3/8	71-1/2	67-5/8	155	176
D5-RETA-72	D6-RETA-72	72	81	75-3/8	83-1/2	79-5/8	177	202

Bigfoot bolting pattern and lagged roller option available.
 Note: Also available in lagged roller. Designated by (RETAI).
 Note: Also available in bi-directional shoe-activated option.
 Designated by (RETBA).

CEMA D

FEEDER / PICKING TROUGHING IDLERS – 5" & 6" DIAMETER

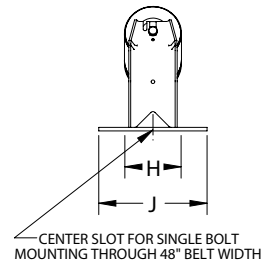
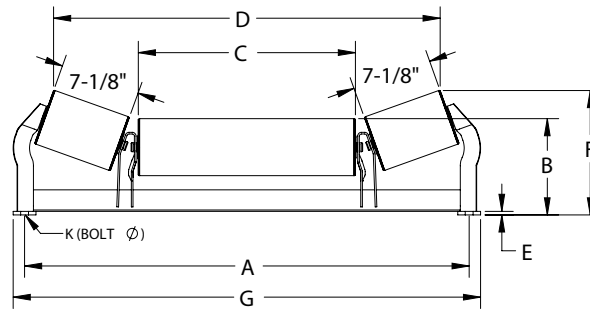

PART NUMBER		BW*	A	B		C	D		E	F		G	H**	J	K	WT (#)	
5"	6"			5"	6"		5"	6"		5"	6"					5"	6"
D5-20P-24	D6-20P-24	24	33	8-1/2	9	13	27-3/4	27-3/8	5/16	11	11-7/16	35	6	9-1/2	5/8	53	63
D5-20P-30	D6-20P-30	30	39	8-1/2	9	19	33-3/4	33-7/16	5/16	11	11-7/16	41	6	9-1/2	5/8	63	75
D5-20P-36	D6-20P-36	36	45	8-1/2	9	25	39-3/4	39-7/16	5/16	11	11-7/16	47	6	9-1/2	5/8	70	84
D5-20P-42	D6-20P-42	42	51	8-7/8	9-3/8	30-3/4	45-15/16	45-5/8	5/16	11-1/16	11-1/2	53	7-1/2	9-1/2	5/8	86	100
D5-20P-48	D6-20P-48	48	57	9-1/4	9-3/4	36-3/4	51-9/16	51-3/16	5/16	11-11/16	12-1/8	59	7-1/2	9-1/2	5/8	98	115
D5-20P-54	D6-20P-54	54	63	9-5/16	9-13/16	42-1/2	57-9/16	57-3/16	3/8	11-3/4	12-3/16	65-1/2	9	11	5/8	110	128
D5-20P-60	D6-20P-60	60	69	9-5/16	9-13/16	48-1/2	63-9/16	63-3/16	3/8	11-3/4	12-3/16	71-1/2	9	11	5/8	118	138
D5-20P-72	D6-20P-72	72	81	9-5/16	9-13/16	60-1/2	75-9/16	75-3/16	3/8	11-3/4	12-3/16	83-1/2	9	11	5/8	136	159

Note: Also available in rubber cushion rollers. Designated by PI. For impact roll only in the center use PCI.

* Belt Width (Reinforcing on 36" BW - 72" BW frame only).

** Recommended Bolt Pattern - See page 75 for minimum and maximum dimensions.

CEMA D IDLERS

TROUGHING IDLERS (UNEQUAL LENGTH ROLLERS) – 5" & 6" DIAMETER

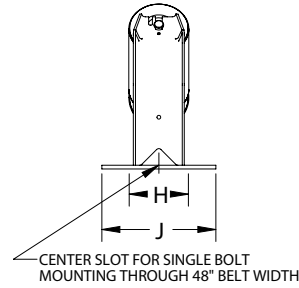
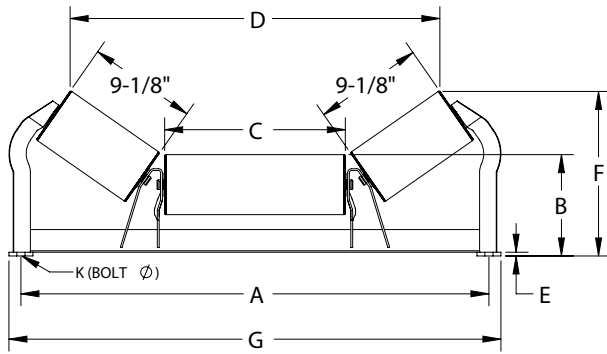

PART NUMBER		BW*	A	B		C	D		E	F		G	H**	J	K	WT	
5"	6"			5"	6"		5"	6"		5"	6"					5"	6"
D5-20U-30	D6-20U-30	30	39	8-1/2	9	15-1/16	33-1/2	33-3/16	5/16	11-11/16	12-1/8	41	6	9-1/2	5/8	63	76
D5-20U-36	D6-20U-36	36	45	8-1/2	9	21-1/16	39-1/2	39-3/16	5/16	11-11/16	12-1/8	47	6	9-1/2	5/8	70	85
D5-20U-42	D6-20U-42	42	51	8-7/8	9-3/8	26-1/2	45-3/16	44-3/4	5/16	12-5/16	12-3/4	53	7-1/2	9-1/2	5/8	86	101
D5-20U-48	D6-20U-48	48	57	9-1/4	9-3/4	32-1/2	51-5/16	50-15/16	5/16	12-3/8	12-13/16	59	7-1/2	9-1/2	5/8	99	116
D5-20U-54	D6-20U-54	54	63	9-5/16	9-13/16	38-1/16	57-5/16	56-15/16	3/8	12-7/16	12-7/8	65-1/2	9	11	5/8	110	128
D5-20U-60	D6-20U-60	60	69	9-5/16	9-13/16	44-1/16	63-5/16	62-15/16	3/8	12-7/16	12-7/8	71-1/2	9	11	5/8	119	139
D5-20U-72	D6-20U-72	72	81	9-5/16	9-13/16	56-1/16	75-5/16	74-15/16	3/8	12-7/16	12-7/8	83-1/2	9	11	5/8	136	160
D5-35U-30	D6-35U-30	30	39	8-1/2	9	15	30-5/8	30-1/16	5/16	13-3/4	14-1/8	41	6	9-1/2	5/8	65	78
D5-35U-36	D6-35U-36	36	45	8-1/2	9	21	36-5/8	36-1/16	5/16	12-3/4	14-1/8	47	6	9-1/2	5/8	72	87
D5-35U-42	D6-35U-42	42	51	8-7/8	9-3/8	26-1/2	42-5/16	41-3/4	5/16	14-3/16	14-9/16	53	7-1/2	9-1/2	5/8	87	103
D5-35U-48	D6-35U-48	48	57	9-1/4	9-3/4	32-1/2	48-1/4	47-11/16	5/16	14-1/2	14-15/16	59	7-1/2	9-1/2	5/8	100	118
D5-35U-54	D6-35U-54	54	63	9-5/16	9-13/16	38-1/16	54-1/4	53-11/16	3/8	14-9/16	15	65-1/2	9	11	5/8	111	130
D5-35U-60	D6-35U-60	60	69	9-5/16	9-13/16	44-1/16	60-1/4	59-11/16	3/8	14-9/16	15	71-1/2	9	11	5/8	120	141
D5-35U-72	D6-35U-72	72	81	9-5/16	9-13/16	56-1/16	72-1/4	71-11/16	3/8	14-9/16	15	83-1/2	9	11	5/8	138	161
D5-45U-30	D6-45U-30	30	39	8-1/2	9	15	28-3/4	28-1/16	5/16	15-1/16	16-3/8	41	6	9-1/2	5/8	67	79
D5-45U-36	D6-45U-36	36	45	8-1/2	9	21	34-3/4	34-1/16	5/16	15-1/16	15-3/8	47	6	9-1/2	5/8	74	88
D5-45U-42	D6-45U-42	42	51	8-7/8	9-3/8	26-1/2	39-1/2	33-13/16	5/16	15-9/16	15-7/8	53	7-1/2	9-1/2	5/8	89	104
D5-45U-48	D6-45U-48	48	57	9-1/4	9-3/4	32-1/2	46-3/4	46-1/16	5/16	15-7/8	13-3/16	59	7-1/2	9-1/2	5/8	102	119
D5-45U-54	D6-45U-54	54	63	9-5/16	9-13/16	38-1/16	52-3/4	52-1/16	3/8	15-15/16	16-1/4	65-1/2	9	11	5/8	113	132
D5-45U-60	D6-45U-60	60	69	9-5/16	9-13/16	44-1/16	58-3/4	58-1/16	3/8	15-15/16	16-1/4	71-1/2	9	11	5/8	122	142
D5-45U-72	D6-45U-72	72	81	9-5/16	9-13/16	56-1/16	70-3/4	70-1/16	3/8	15-15/16	16-1/4	83-1/2	9	11	5/8	140	163

20°

35°

45°

* Belt Width (Reinforcing on 36" BW - 72" BW Impact Frame only).

** Recommended Bolt Pattern - See page 75 for minimum and maximum dimensions.

NOTE: Also available in rubber cushioned roller. Designated by (UI).

CEMA E IDLERS

TROUGHING IDLER (EQUAL LENGTH ROLLERS) – 6" & 7" DIAMETER

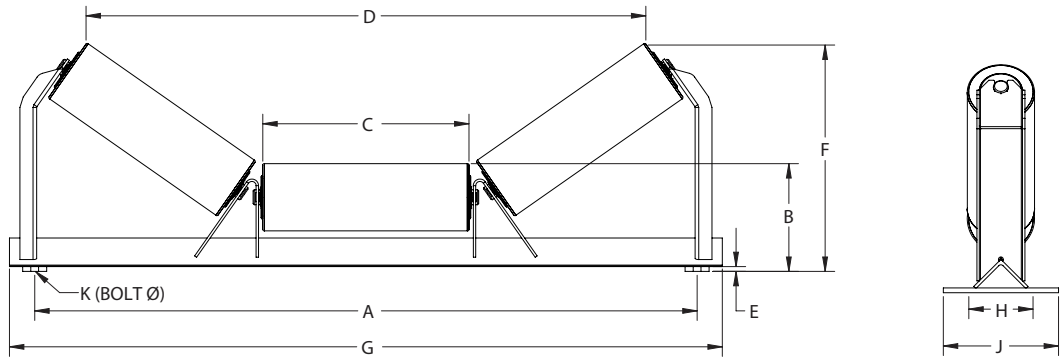

	PART NUMBER		BW	A	B		C	D		E	F		G	H	J	K	WT (#)	
	6"	7"			6"	7"		6"	7"		6"	7"					6"	7"
20°	E6-20E-36	E7-20E-36	36	45	10-3/4	11-1/4	12-3/4	39-7/8	39-1/2	1/2	15-3/8	15-13/16	49	9-1/2	12	3/4	158	169
	E6-20E-42	E7-20E-42	42	51	10-3/4	11-1/4	14-3/4	45-5/8	45-1/4	1/2	16-1/16	16-1/2	55	9-1/2	12	3/4	174	187
	E6-20E-48	E7-20E-48	48	57	10-3/4	11-1/4	17-1/2	53-9/16	53-3/16	1/2	17	17-7/16	63	9-1/2	12	3/4	197	212
	E6-20E-54	E7-20E-54	54	63	10-3/4	11-1/4	19-1/2	59-5/16	58-15/16	1/2	17-11/16	18-1/8	68-1/2	9-1/2	12	3/4	213	229
	E6-20E-60	E7-20E-60	60	69	10-3/4	11-1/4	21-1/2	65-1/16	64-11/16	1/2	18-3/8	18-13/16	74-1/4	9-1/2	12	3/4	229	247
	E6-20E-72	E7-20E-72	72	81	11-1/2	12	25-1/2	76-9/16	76-3/16	1/2	20-1/2	20-15/16	86	9-1/2	12	3/4	264	284
	E6-20E-84	E7-20E-84	84	93	11-3/4	12-1/4	29-1/2	88-1/16	87-3/4	1/2	22-1/16	22-9/16	97-1/4	12	14	3/4	299	321
	E6-20E-96	E7-20E-96	96	105	11-3/4	12-1/4	33-1/2	99-5/8	99-1/4	1/2	23-7/16	23-15/16	109	12	14	3/4	331	357
	35°	E6-35E-36	E7-35E-36	36	45	10-3/4	11-1/4	12-3/4	35-13/16	35-1/4	1/2	18-1/4	18-11/16	49	9-1/2	12	3/4	163
E6-35E-42		E7-35E-42	42	51	10-3/4	11-1/4	14-3/4	41-1/16	40-1/2	1/2	19-7/16	19-13/16	55	9-1/2	12	3/4	180	192
E6-35E-48		E7-35E-48	48	57	10-3/4	11-1/4	17-1/2	48-5/16	47-3/4	1/2	21	21-7/16	63	9-1/2	12	3/4	203	217
E6-35E-54		E7-35E-54	54	63	10-3/4	11-1/4	19-1/2	53-5/8	53-1/16	1/2	22-1/8	22-9/16	68-1/2	9-1/2	12	3/4	220	235
E6-35E-60		E7-35E-60	60	69	10-3/4	11-1/4	21-1/2	58-7/8	58-5/16	1/2	23-5/16	23-11/16	74-1/4	9-1/2	12	3/4	236	253
E6-35E-72		E7-35E-72	72	81	11-1/2	12	25-1/2	69-7/16	68-7/8	1/2	26-3/8	26-3/4	86	9-1/2	12	3/4	272	292
E6-35E-84		E7-35E-84	84	93	11-3/4	12-1/4	29-1/2	80	79-7/16	1/2	28-7/8	29-5/16	97-1/4	12	14	3/4	308	330
E6-35E-96		E7-35E-96	96	105	11-3/4	12-1/4	33-1/2	90-9/16	89-15/16	1/2	31-3/16	31-9/16	109	12	14	3/4	342	367
45°		E6-45E-36	E7-45E-36	36	45	10-3/4	11-1/4	12-3/4	32-5/16	31-5/8	1/2	19-15/16	20-5/16	49	9-1/2	12	3/4	167
	E6-45E-42	E7-45E-42	42	51	10-3/4	11-1/4	14-3/4	37-1/8	36-7/16	1/2	21-3/8	21-11/16	55	9-1/2	12	3/4	184	198
	E6-45E-48	E7-45E-48	48	57	10-3/4	11-1/4	17-1/2	43-3/4	43-1/16	1/2	23-5/16	23-5/8	63	9-1/2	12	3/4	208	224
	E6-45E-54	E7-45E-54	54	63	10-3/4	11-1/4	19-1/2	48-5/8	47-15/16	1/2	24-11/16	26-1/16	68-1/2	9-1/2	12	3/4	225	242
	E6-45E-60	E7-45E-60	60	69	10-3/4	11-1/4	21-1/2	53-7/16	52-3/4	1/2	26-1/8	26-1/2	74-1/4	9-1/2	12	3/4	242	261
	E6-45E-72	E7-45E-72	72	81	11-1/2	12	25-1/2	63-1/16	62-3/8	1/2	29-11/16	30-1/16	86	9-1/2	12	3/4	279	300
	E6-45E-84	E7-45E-84	84	93	11-3/4	12-1/4	29-1/2	72-3/4	72-1/16	1/2	32-3/4	33-1/8	97-1/4	12	14	3/4	315	339
	E6-45E-96	E7-45E-96	96	105	11-3/4	12-1/4	33-1/2	82-7/16	81-3/4	1/2	35-9/16	35-15/16	109	12	14	3/4	350	377

CEMA E IDLERS

RUBBER CUSHION IMPACT TROUGHING IDLERS – 6” & 7” DIAMETER

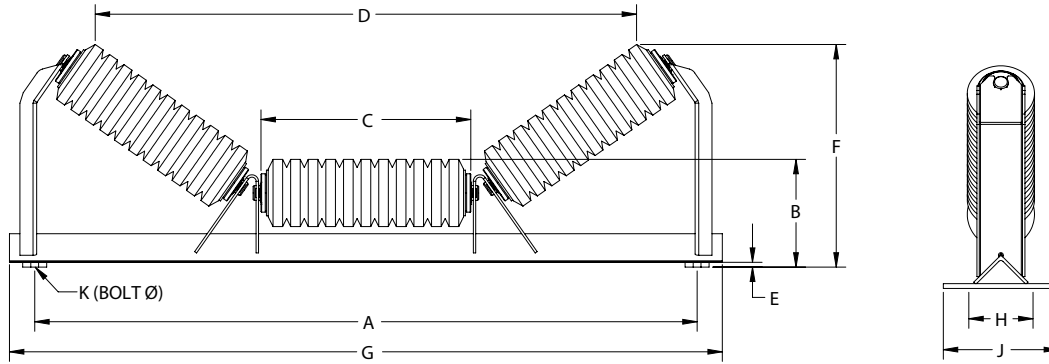

PART NUMBER		BW	A	B		C	D		E	F		G	H*	J	K	WT (#)	
6"	7"			6"	7"		6"	7"		6"	7"					6"	7"
E6-20EI-36	E7-20EI-36	36	45	10-3/4	11-1/4	13-1/8	37-3/4	37-3/8	1/2	15-1/16	15-1/2	49	9-1/2	12	3/4	147	158
E6-20EI-42	E7-20EI-42	42	51	10-3/4	11-1/4	15-1/8	43-1/2	43-1/8	1/2	15-3/4	16-3/16	55	9-1/2	12	3/4	164	177
E6-20EI-48	E7-20EI-48	48	57	10-3/4	11-1/4	17-7/8	51-7/16	51-1/16	1/2	16-11/16	17-1/8	63	9-1/2	12	3/4	188	205
E6-20EI-54	E7-20EI-54	54	63	10-3/4	11-1/4	19-7/8	57-3/16	56-7/8	1/2	17-3/16	17-13/16	68-1/2	9-1/2	12	3/4	205	223
E6-20EI-60	E7-20EI-60	60	69	10-3/4	11-1/4	21-7/8	62-15/16	62-9/16	1/2	18-1/16	18-1/2	74-1/4	9-1/2	12	3/4	221	241
E6-20EI-72	E7-20EI-72	72	81	11-1/2	12	25-7/8	74-7/16	74-1/8	1/2	20-3/16	20-5/8	86	9-1/2	12	3/4	256	280
E6-20EI-84	E7-20EI-84	84	93	11-3/4	12-1/4	29-7/8	85-15/16	85-9/16	1/2	21-13/16	22-1/4	97-1/4	12	14	3/4	290	318
E6-20EI-96	E7-20EI-96	96	105	11-3/4	12-1/4	33-7/8	97-1/2	97-1/8	1/2	23-1/8	23-5/8	109	12	14	3/4	324	355
E6-35EI-36	E7-35EI-36	36	45	10-3/4	11-1/4	13-1/8	33-7/8	33-5/16	1/2	17-3/4	18-3/16	49	9-1/2	12	3/4	153	164
E6-35EI-42	E7-35EI-42	42	51	10-3/4	11-1/4	15-1/8	39-3/16	38-9/16	1/2	18-15/16	19-5/16	55	9-1/2	12	3/4	170	183
E6-35EI-48	E7-35EI-48	48	57	10-3/4	11-1/4	17-7/8	46-7/16	45-7/8	1/2	20-1/2	20-7/8	63	9-1/2	12	3/4	195	211
E6-35EI-54	E7-35EI-54	54	63	10-3/4	11-1/4	19-7/8	54-15/16	51-1/8	1/2	21-1/2	22-1/16	68-1/2	9-1/2	12	3/4	212	230
E6-35EI-60	E7-35EI-60	60	69	10-3/4	11-1/4	21-7/8	56-15/16	56-3/8	1/2	22-13/16	23-3/16	74-1/4	9-1/2	12	3/4	228	249
E6-35EI-72	E7-35EI-72	72	81	11-1/2	12	25-7/8	67-1/2	66-15/16	1/2	25-13/16	26-1/4	86	9-1/2	12	3/4	264	288
E6-35EI-84	E7-35EI-84	84	93	11-3/4	12-1/4	29-7/8	78-1/16	77-1/2	1/2	28-3/8	28-3/4	97-1/4	12	14	3/4	300	328
E6-35EI-96	E7-35EI-96	96	105	11-3/4	12-1/4	33-7/8	88-5/8	88-1/16	1/2	30-11/16	31-1/16	109	12	14	3/4	334	365
E6-45EI-36	E7-45EI-36	36	45	10-3/4	11-1/4	13-1/8	30-5/8	29-7/8	1/2	19-1/4	19-5/8	49	9-1/2	12	3/4	157	168
E6-45EI-42	E7-45EI-42	42	51	10-3/4	11-1/4	15-1/8	35-7/16	36-11/16	1/2	20-11/16	21-1/16	55	9-1/2	12	3/4	174	187
E6-45EI-48	E7-45EI-48	48	57	10-3/4	11-1/4	17-7/8	42-1/16	41-3/8	1/2	22-5/8	23	63	9-1/2	12	3/4	200	216
E6-45EI-54	E7-45EI-54	54	63	10-3/4	11-1/4	19-7/8	45-15/16	46-3/16	1/2	24-1/16	24-7/16	68-1/2	9-1/2	12	3/4	217	235
E6-45EI-60	E7-45EI-60	60	69	10-3/4	11-1/4	21-7/8	51-11/16	51	1/2	25-7/16	25-13/16	74-1/4	9-1/2	12	3/4	234	254
E6-45EI-72	E7-45EI-72	72	81	11-1/2	12	25-7/8	61-3/8	60-11/16	1/2	29-1/16	29-3/8	86	9-1/2	12	3/4	271	295
E6-45EI-84	E7-45EI-84	84	93	11-3/4	12-1/4	29-7/8	71-1/16	70-5/16	1/2	32-1/16	32-7/16	97-1/4	12	14	3/4	308	337
E6-45EI-96	E7-45EI-96	96	105	11-3/4	12-1/4	33-7/8	80-3/4	80	1/2	34-15/16	35-5/16	109	12	14	3/4	342	374

20°

35°

45°

RUBBER CUSHION RETURN IDLERS – 6” & 7” DIAMETER

PART NUMBER		BW	A	B	C	WT (#)**	
6"	7"					6"	7"
E6-RETI-36	E7-RETI-36	36	45	39	48	87	93
E6-RETI-42	E7-RETI-42	42	51	45	54	97	104
E6-RETI-48	E7-RETI-48	48	57	51	60	108	115
E6-RETI-54	E7-RETI-54	54	63	57	66	117	124
E6-RETI-60	E7-RETI-60	60	69	63	72	127	135
E6-RETI-72	E7-RETI-72	72	81	75	84	147	155
E6-RETI-84	E7-RETI-84	84	93	87	96	169	179
E6-RETI-96	E7-RETI-96	96	105	99	108	187	197

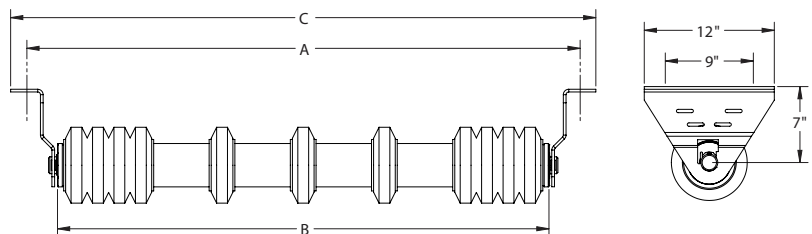

* Recommended Bolt Pattern - See page 75 for minimum and maximum dimensions.

** All weights include brackets, individual bracket weights available on pages 74 and 75. Brackets are sold separately.

CEMA E IDLERS

SELF-ALIGNING TROUGHING IDLER – 6" & 7" DIAMETER

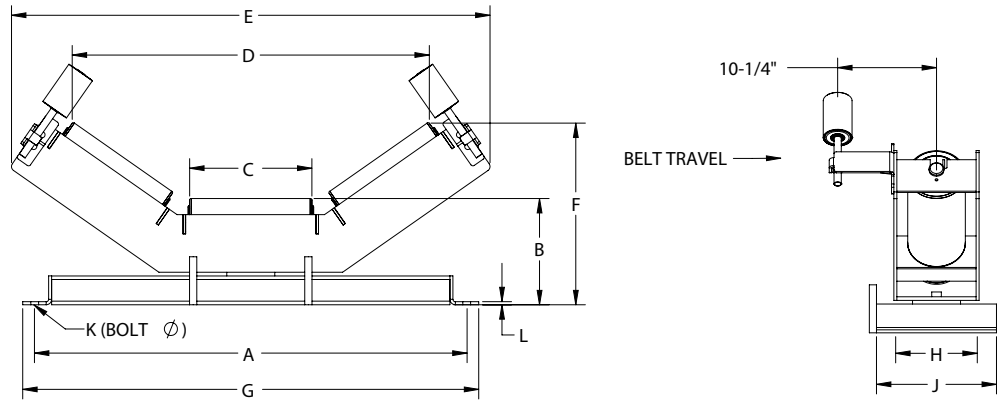

	PART NUMBER		BW	A	B		C	D		E	F		G	H	J	K	L	WT (#)	
	6"	7"			6"	7"		6"	7"		6"	7"						6"	7"
20°	E6-20EA-36	E7-20EA-36	36	45	11-1/16	11-9/16	12-3/4	42-5/8	42-1/4	52-15/16	15-13/16	16-5/16	47-1/2	9-1/2	12-1/2	3/4	5/16	259	270
	E6-20EA-42	E7-20EA-42	42	51	11-1/16	11-9/16	14-3/4	48-3/8	48	58-3/4	16-1/2	17	53-1/2	9-1/2	12-1/2	3/4	5/16	284	296
	E6-20EA-48	E7-20EA-48	48	57	11-1/16	11-9/16	17-1/2	56-5/16	55-15/16	66-5/8	17-7/16	17-15/16	59-1/2	9-1/2	12-1/2	3/4	5/16	316	330
	E6-20EA-54	E7-20EA-54	54	63	11-1/16	11-9/16	19-1/2	61-1/16	61-11/16	72-3/8	18-1/8	18-5/8	65-1/2	9-1/2	12-1/2	3/4	5/16	341	357
	E6-20EA-60	E7-20EA-60	60	69	11-1/16	11-9/16	21-1/2	67-13/16	67-7/16	78-3/16	18-13/16	19-5/16	71-1/2	9-1/2	12-1/2	3/4	5/16	366	383
	E6-20EA-72	E7-20EA-72	72	81	12-1/16	12-9/16	25-1/2	79-5/16	79	89-11/16	21-3/16	21-11/16	83-1/2	9-1/2	12-1/2	3/4	5/16	417	436
	E6-20EA-84	E7-20EA-84	84	93	12-1/16	12-9/16	29-1/2	90-13/16	90-1/2	101-3/16	22-9/16	23	95-1/2	12	15	3/4	5/16	495	517
	E6-20EA-96	E7-20EA-96	96	105	12-1/16	12-9/16	33-1/2	102-3/8	102	112-11/16	23-15/16	24-3/8	107-1/2	12	15	3/4	5/16	548	573
	E6-35EA-36	E7-35EA-36	36	45	11-1/16	11-9/16	12-3/4	36-3/4	36-3/16	49-7/8	18-15/16	19-5/8	47-1/2	9-1/2	12-1/2	3/4	5/16	261	272
E6-35EA-42	E7-35EA-42	42	51	11-1/16	11-9/16	14-3/4	42	41-7/16	55-1/8	20-1/16	20-1/2	53-1/2	9-1/2	12-1/2	3/4	5/16	286	299	
E6-35EA-48	E7-35EA-48	48	57	11-1/16	11-9/16	17-1/2	49-1/4	48-11/16	62-3/8	21-5/8	22-1/16	59-1/2	9-1/2	12-1/2	3/4	5/16	318	332	
E6-35EA-54	E7-35EA-54	54	63	11-1/16	11-9/16	19-1/2	54-9/16	54	67-5/8	22-13/16	23-3/16	65-1/2	9-1/2	12-1/2	3/4	5/16	343	359	
E6-35EA-60	E7-35EA-60	60	69	11-1/16	11-9/16	21-1/2	59-13/16	59-1/4	72-15/16	23-15/16	24-3/8	71-1/2	9-1/2	12-1/2	3/4	5/16	369	386	
E6-35EA-72	E7-35EA-72	72	81	12-1/16	12-9/16	25-1/2	70-3/8	69-13/16	83-1/2	27-1/4	27-5/8	83-1/2	9-1/2	12-1/2	3/4	5/16	419	439	
E6-35EA-84	E7-35EA-84	84	93	12-1/16	12-9/16	29-1/2	80-15/16	80-3/8	94-1/16	29-1/2	29-15/16	95-1/2	12	15	3/4	5/16	498	520	
E6-35EA-96	E7-35EA-96	96	105	12-1/16	12-9/16	33-1/2	91-1/2	90-15/16	104-9/16	31-13/16	32-1/4	107-1/2	12	15	3/4	5/16	552	577	
35°	E6-45EA-36	E7-45EA-36	36	45	11-1/16	11-9/16	12-3/4	33-5/16	32-5/8	47-1/8	20-5/8	21	47-1/2	9-1/2	12-1/2	3/4	5/16	259	270
	E6-45EA-42	E7-45EA-42	42	51	11-1/16	11-9/16	14-3/4	37-1/16	37-7/16	51-15/16	22-1/16	22-3/8	53-1/2	9-1/2	12-1/2	3/4	5/16	284	296
	E6-45EA-48	E7-45EA-48	48	57	11-1/16	11-9/16	17-1/2	44-13/16	44-1/16	58-9/16	24	24-5/16	59-1/2	9-1/2	12-1/2	3/4	5/16	315	330
	E6-45EA-54	E7-45EA-54	54	63	11-1/16	11-9/16	19-1/2	49-5/8	48-15/16	63-7/16	25-3/8	25-3/4	65-1/2	9-1/2	12-1/2	3/4	5/16	340	356
	E6-45EA-60	E7-45EA-60	60	69	11-1/16	11-9/16	21-1/2	54-7/16	53-3/4	68-1/4	26-13/16	27-3/16	71-1/2	9-1/2	12-1/2	3/4	5/16	365	382
	E6-45EA-72	E7-45EA-72	72	81	12-1/16	12-9/16	25-1/2	64-1/8	63-3/8	77-7/8	30-1/16	31	83-1/2	9-1/2	12-1/2	3/4	5/16	415	435
	E6-45EA-84	E7-45EA-84	84	93	12-1/16	12-9/16	29-1/2	73-3/4	73-1/16	87-9/16	33-1/2	33-13/16	95-1/2	12	15	3/4	5/16	493	515
	E6-45EA-96	E7-45EA-96	96	105	12-1/16	12-9/16	33-1/2	83-7/16	82-11/16	97-3/16	36-5/16	36-11/16	107-1/2	12	15	3/4	5/16	546	571
	45°	E6-45EA-36	E7-45EA-36	36	45	11-1/16	11-9/16	12-3/4	33-5/16	32-5/8	47-1/8	20-5/8	21	47-1/2	9-1/2	12-1/2	3/4	5/16	259
E6-45EA-42		E7-45EA-42	42	51	11-1/16	11-9/16	14-3/4	37-1/16	37-7/16	51-15/16	22-1/16	22-3/8	53-1/2	9-1/2	12-1/2	3/4	5/16	284	296
E6-45EA-48		E7-45EA-48	48	57	11-1/16	11-9/16	17-1/2	44-13/16	44-1/16	58-9/16	24	24-5/16	59-1/2	9-1/2	12-1/2	3/4	5/16	315	330
E6-45EA-54		E7-45EA-54	54	63	11-1/16	11-9/16	19-1/2	49-5/8	48-15/16	63-7/16	25-3/8	25-3/4	65-1/2	9-1/2	12-1/2	3/4	5/16	340	356
E6-45EA-60		E7-45EA-60	60	69	11-1/16	11-9/16	21-1/2	54-7/16	53-3/4	68-1/4	26-13/16	27-3/16	71-1/2	9-1/2	12-1/2	3/4	5/16	365	382
E6-45EA-72		E7-45EA-72	72	81	12-1/16	12-9/16	25-1/2	64-1/8	63-3/8	77-7/8	30-1/16	31	83-1/2	9-1/2	12-1/2	3/4	5/16	415	435
E6-45EA-84		E7-45EA-84	84	93	12-1/16	12-9/16	29-1/2	73-3/4	73-1/16	87-9/16	33-1/2	33-13/16	95-1/2	12	15	3/4	5/16	493	515
E6-45EA-96		E7-45EA-96	96	105	12-1/16	12-9/16	33-1/2	83-7/16	82-11/16	97-3/16	36-5/16	36-11/16	107-1/2	12	15	3/4	5/16	546	571

CEMA E IDLERS

RETURN IDLERS – 6" & 7" DIAMETER

PART NUMBER		BW	A	B	C	WT (#)*	
6"	7"					6"	7"
E6-RET-30	E7-RET-30	30	39	33	42	85	93
E6-RET-36	E7-RET-36	36	45	39	48	97	106
E6-RET-42	E7-RET-42	42	51	45	54	108	119
E6-RET-48	E7-RET-48	48	57	51	60	120	132
E6-RET-54	E7-RET-54	54	63	57	66	132	145
E6-RET-60	E7-RET-60	60	69	63	72	144	158
E6-RET-72	E7-RET-72	72	81	75	84	167	184
E6-RET-84	E7-RET-84	84	93	87	96	190	211
E6-RET-96	E7-RET-96	96	105	99	108	214	237

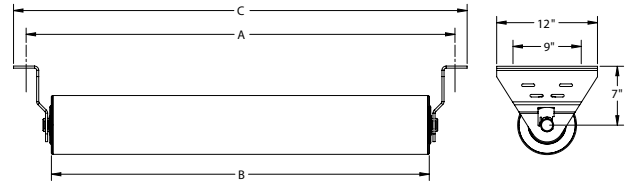

RUBBER CUSHION FLAT IDLERS – 6" & 7" DIAMETER

PART NUMBER		BW	A	B	C	WT (#)*	
6"	7"					6"	7"
E6-FLTI-36	E7-FLTI-36	36	45	39-3/8	47-1/2	96	108
E6-FLTI-42	E7-FLTI-42	42	51	45-3/8	53-1/2	107	122
E6-FLTI-48	E7-FLTI-48	48	57	51-3/8	59-1/2	119	135
E6-FLTI-54	E7-FLTI-54	54	63	57-3/8	65-1/2	132	150
E6-FLTI-60	E7-FLTI-60	60	69	63-3/8	71-1/2	144	164
E6-FLTI-72	E7-FLTI-72	72	81	75-3/8	83-1/2	167	191
E6-FLTI-84	E7-FLTI-84	84	93	87-3/8	95-1/2	191	218
E6-FLTI-96	E7-FLTI-96	96	105	99-3/8	107-1/2	214	245

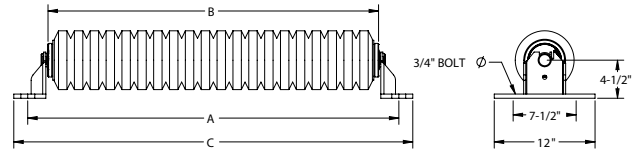

FLAT IDLERS – 6" & 7" DIAMETER

PART NUMBER		BW	A	B	C	WT (#)*	
6"	7"					6"	7"
E6-FLT-30	E7-FLT-30	30	39	33	41-1/2	86	95
E6-FLT-36	E7-FLT-36	36	45	39	47-1/2	98	108
E6-FLT-42	E7-FLT-42	42	51	45	53-1/2	110	121
E6-FLT-48	E7-FLT-48	48	57	51	59-1/2	122	134
E6-FLT-54	E7-FLT-54	54	63	57	65-1/2	133	147
E6-FLT-60	E7-FLT-60	60	69	63	71-1/2	145	160
E6-FLT-72	E7-FLT-72	72	81	75	83-1/2	168	186
E6-FLT-84	E7-FLT-84	84	93	87	95-1/2	192	212
E6-FLT-96	E7-FLT-96	96	105	99	107-1/2	215	238

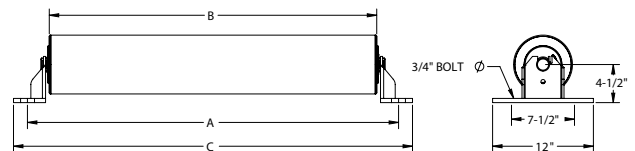

RETURN SELF-ALIGNER IDLERS – 6" & 7" DIAMETER

PART NUMBER		BW	A	B	C	D	WT (#)	
6"	7"						6"	7"
E6-RETA-36	E7-RETA-36	36	45	39	48-1/2	45-1/2	285	294
E6-RETA-42	E7-RETA-42	42	51	45	54-1/2	51-1/2	308	319
E6-RETA-48	E7-RETA-48	48	57	51	60-1/2	57-1/2	331	343
E6-RETA-54	E7-RETA-54	54	63	57	66-1/2	63 1/2	355	368
E6-RETA-60	E7-RETA-60	60	69	63	72-1/2	69-1/2	377	392
E6-RETA-72	E7-RETA-72	72	81	75	84-1/2	81-1/2	423	440
E6-RETA-84	E7-RETA-84	84	93	87	96-1/2	93-1/2	469	489
E6-RETA-96	E7-RETA-96	96	105	99	108-1/2	105-1/2	515	538

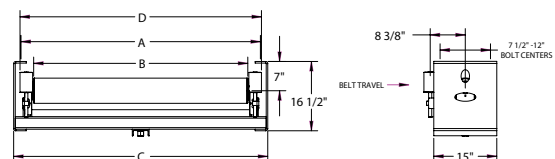

* All weights include brackets, individual bracket weights are listed on page 74 and 75. Brackets are sold separately.

CEMA E IDLERS

URATHON® RETURN ROLL – 6” & 7” DIAMETER

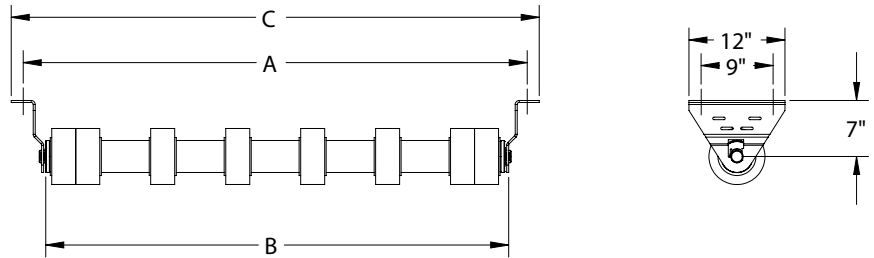

PART NUMBERS		BW	A	B	C	WT (#)*	
6"	7"					6"	7"
E6-RETU-36	E7-RETU-36	36	45	39-3/8	48	88	95
E6-RETU-42	E7-RETU-42	42	51	45-3/8	54	99	107
E6-RETU-48	E7-RETU-48	48	57	51-3/8	60	109	116
E6-RETU-54	E7-RETU-54	54	63	57-3/8	66	120	129
E6-RETU-60	E7-RETU-60	60	69	63-3/8	72	131	141
E6-RETU-72	E7-RETU-72	72	81	75-3/8	84	155	168
E6-RETU-84	E7-RETU-84	84	93	87-3/8	96	175	189
E6-RETU-96	E7-RETU-96	96	105	99-3/8	108	196	211

Note: Spiral Urathon is only available in 6” diameter. To order Spiral Urathon version add SP after RETU in the part number

V-RETURN – 6” & 7” DIAMETER

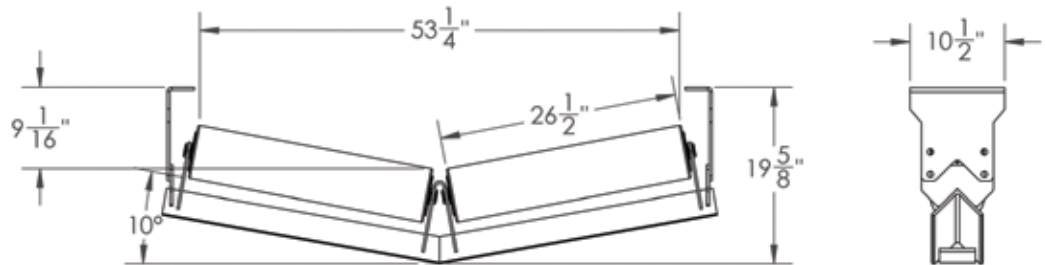

PART NUMBERS		BW	A	B		C	D		E	F	G	WT (#)	
6"	7"			6"	7"		6"	7"				6"	7"
E6-10RETV-36	E7-10RETV-36	36	45	7-3/4	7-1/4	20-1/2	42-3/4	42-9/16	48-1/2	16-5/16	10-1/2	200	211
E6-10RETV-42	E7-10RETV-42	42	51	8-1/4	7-3/4	23-1/2	48-3/4	48-9/16	54-1/2	16-13/16	10-1/2	221	233
E6-10RETV-48	E7-10RETV-48	48	57	8-13/16	8-5/16	26-1/2	54-3/4	54-9/16	60-1/2	17-3/8	10-1/2	242	255
E6-10RETV-54	E7-10RETV-54	54	63	9-5/16	8-13/16	29-1/2	60-3/4	60-9/16	66-1/2	17-7/8	10-1/2	262	277
E6-10RETV-60	E7-10RETV-60	60	69	9-15/16	9-7/16	33	66-3/4	66-9/16	72-1/2	18-7/16	10-1/2	285	301
E6-10RETV-72	E7-10RETV-72	72	81	10-15/16	10-7/16	39	78-3/4	78-9/16	84-1/2	19-1/2	10-1/2	326	345
E6-10RETV-84	E7-10RETV-84	84	93	12	11-1/2	45	90-11/16	90-9/16	96-1/2	20-9/16	10-1/2	368	389
E6-10RETV-96	E7-10RETV-96	96	105	13-1/16	12-9/16	51	102-3/4	102-9/16	108-1/2	21-9/16	10-1/2	409	433

* All weights include brackets, individual bracket weights are listed on page 74 and 75. Brackets are sold separately.

CEMA F IDLERS

TROUGHING IDLERS (EQUAL LENGTH ROLLERS) – 7" DIAMETER

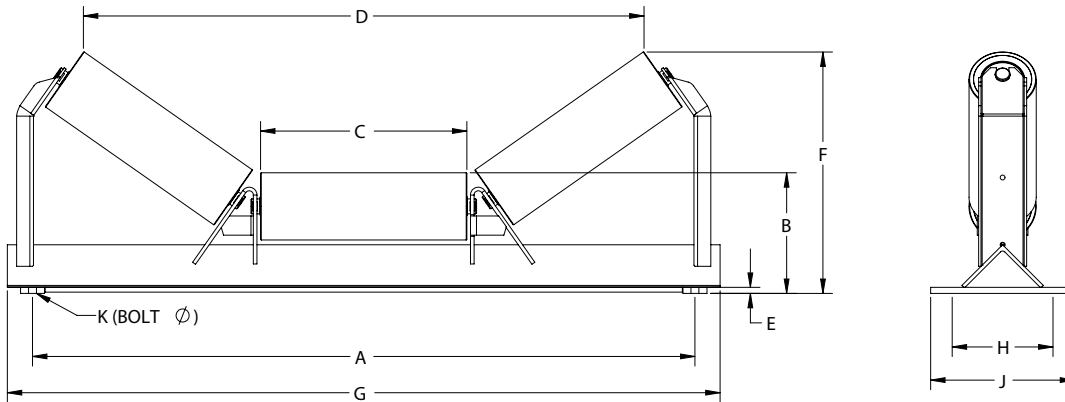

7" PART NUMBER	BW	A	B	C	D	E	F	G	H	J	K	WT (#)
F7-20E-36	36	45	12-9/16	12-3/4	39-1/4	5/8	17-1/8	49-1/2	10-1/2	15	3/4	382
F7-20E-42	42	51	12-9/16	14-3/4	45-1/8	5/8	17-13/16	55	10-1/2	15	3/4	421
F7-20E-48	48	57	12-9/16	17-1/2	53-1/16	5/8	18-3/4	63	10-1/2	15	3/4	471
F7-20E-54	54	63	12-9/16	19-1/2	58-3/4	5/8	19-3/8	68-1/2	10-1/2	15	3/4	510
F7-20E-60	60	69	12-9/16	21-1/2	64-1/2	5/8	20-1/16	74-1/4	10-1/2	15	3/4	548
F7-20E-72	72	81	12-9/16	25-1/2	76-1/8	5/8	21-1/2	86	10-1/2	15	3/4	626
F7-20E-84	84	93	12-9/16	29-1/2	87-5/8	5/8	22-7/8	97-1/2	10-1/2	15	3/4	703
F7-20E-96	96	105	12-9/16	33-1/2	99-1/16	5/8	24-3/16	109	10-1/2	15	3/4	780
F7-35E-36	36	45	12-9/16	12-3/4	35-5/16	5/8	20-1/8	49-1/2	10-1/2	15	3/4	393
F7-35E-42	42	51	12-9/16	14-3/4	40-5/8	5/8	21-1/4	55	10-1/2	15	3/4	432
F7-35E-48	48	57	12-9/16	17-1/2	47-7/8	5/8	22-13/16	63	10-1/2	15	3/4	483
F7-35E-54	54	63	12-9/16	19-1/2	53-1/8	5/8	24	68-1/2	10-1/2	15	3/4	522
F7-35E-60	60	69	12-9/16	21-1/2	58-3/8	5/8	25-1/8	74-1/4	10-1/2	15	3/4	561
F7-35E-72	72	81	12-9/16	25-1/2	68-15/16	5/8	27-7/16	86	10-1/2	15	3/4	639
F7-35E-84	84	93	12-9/16	29-1/2	79-1/2	5/8	29-3/4	97-1/2	10-1/2	15	3/4	717
F7-35E-96	96	105	12-9/16	33-1/2	90-1/16	5/8	32	109	10-1/2	15	3/4	796

20°

35°

Also available in Aligners, Impacts, and Returns.

COMPONENT PARTS AND REPLACEMENT ROLLS

REPLACEMENT ROLLS

CEMA B REPLACEMENT IDLER ROLLS						
BW	ASSEMBLED ROLL APPROX. LENGTH	4" DIA. ROLL PART NUMBER	WT (#)	5" DIA. ROLL PART NUMBER	WT (#)	
Equal Length Idler Rolls	14 & 16	6-1/16	B4-14	4	B5-14	6
	18	7-1/16	B4-18	5	B5-18	7
	20	7-11/16	B4-20	5	B5-20	7
	24	9-1/16	B4-24	6	B5-24	8
	30	11-1/16	B4-30	7	B5-30	10
	36	13-1/16	B4-36	8	B5-36	11
	42	15-1/16	B4-42	9	B5-42	13
	48	17-1/16	B4-48	10	B5-48	14
Rubber Impact Idler Rolls	18	7-1/16	B4-EI-18	6	B5-EI-18	7
	20	7-11/16	B4-EI-20	7	B5-EI-20	8
	24	9-1/16	B4-EI-24	8	B5-EI-24	9
	30	11-1/16	B4-EI-30	9	B5-EI-30	11
	36	13-1/16	B4-EI-36	11	B5-EI-36	13
	42	15-1/16	B4-EI-42	12	B5-EI-42	15
	48	17-1/16	B4-EI-48	14	B5-EI-48	17

CEMA C REPLACEMENT IDLER ROLLS								
BW	ASSEMBLED ROLL APPROX. LENGTH	4" DIA. ROLL PART NUMBER	WT (#)	5" DIA. ROLL PART NUMBER	WT (#)	6" DIA. ROLL PART NUMBER	WT (#)	
Equal Length Idler Rolls	18	7-1/16	C4-18	6	C5-18	8	C6-18	10
	24	9-1/16	C4-24	7	C5-24	9	C6-24	13
	30	11-1/16	C4-30	8	C5-30	11	C6-30	15
	36	13-1/16	C4-36	9	C5-36	12	C6-36	17
	42	15-1/16	C4-42	10	C5-42	14	C6-42	19
	48	17-1/16	C4-48	11	C5-48	15	C6-48	21
	54	19-1/16	C4-54	12	C5-54	17	C6-54	24
	60	21-1/16	C4-60	13	C5-60	19	C6-60	26
Rubber Impact Idler Rolls	18	7-1/16	C4-EI-18	7	C5-EI-18	8	C6-EI-18	10
	24	9-1/16	C4-EI-24	8	C5-EI-24	10	C6-EI-24	13
	30	11-1/16	C4-EI-30	10	C5-EI-30	12	C6-EI-30	15
	36	13-1/16	C4-EI-36	12	C5-EI-36	14	C6-EI-36	18
	42	15-1/16	C4-EI-42	13	C5-EI-42	16	C6-EI-42	21
	48	17-1/16	C4-EI-48	15	C5-EI-48	18	C6-EI-48	23
	54	19-1/16	C4-EI-54	17	C5-EI-54	20	C6-EI-54	26
	60	21-1/16	C4-EI-60	18	C5-EI-60	23	C6-EI-60	29

COMPONENT PARTS AND REPLACEMENT ROLLS

REPLACEMENT ROLLS

CEMA D REPLACEMENT IDLER ROLLS					
BW	ROLL LENGTH*	5" DIA. ROLL PART NUMBER	WT (#)	6" DIA. ROLL PART NUMBER	WT (#)
18	7-1/16	D5-18	10	D6-18	12
24	9-1/16	D5-24	11	D6-24	15
30	11-1/16	D5-30	13	D6-30	17
36	13-1/16	D5-36	15	D6-36	20
42	15-1/16	D5-42	16	D6-42	22
48	17-1/16	D5-48	18	D6-48	24
54	19-1/16	D5-54	20	D6-54	27
60	21-1/16	D5-60	22	D6-60	29
72	25-1/16	D5-72	25	D6-72	34
18	7-1/16	D5-EI-18	11	D6-EI-18	13
24	9-1/16	D5-EI-24	14	D6-EI-24	16
30	11-1/16	D5-EI-30	16	D6-EI-30	19
36	13-1/16	D5-EI-36	19	D6-EI-36	22
42	15-1/16	D5-EI-42	22	D6-EI-42	26
48	17-1/16	D5-EI-48	26	D6-EI-48	29
54	19-1/16	D5-EI-54	27	D6-EI-54	32
60	21-1/16	D5-EI-60	30	D6-EI-60	36
72	25-1/16	D5-EI-72	36	D6-EI-72	42

Equal Length Idler Rolls

Rubber Impact Idler Rolls

CEMA E REPLACEMENT IDLER ROLLS					
BW	ROLL LENGTH*	6" DIA. ROLL PART NUMBER	WT (#)	7" DIA. ROLL PART NUMBER	WT (#)
36	12-3/4	E6-36	32	E7-36	36
42	14-3/4	E6-42	36	E7-42	40
48	17-1/2	E6-48	41	E7-48	46
54	19-1/2	E6-54	45	E7-54	51
60	21-1/2	E6-60	49	E7-60	55
72	25-1/2	E6-72	57	E7-72	64
84	29-1/2	E6-84	65	E7-84	72
96	33-1/2	E6-96	73	E7-96	81
36	12-3/4	E6-EI-36	29	E7-EI-36	29
42	14-3/4	E6-EI-42	33	E7-EI-42	33
48	17-1/2	E6-EI-48	39	E7-EI-48	39
54	19-1/2	E6-EI-54	43	E7-EI-54	43
60	21-1/2	E6-EI-60	47	E7-EI-60	47
72	25-1/2	E6-EI-72	54	E7-EI-72	54
84	29-1/2	E6-EI-84	62	E7-EI-84	62
96	33-1/2	E6-EI-96	70	E7-EI-96	70

Equal Length Idler Rolls

Rubber Impact Idler Rolls

*Assembled Roll Approx. Length

*Assembled Roll Approx. Length

OTHER PARTS



Hex Nut Adaptor

PART NUMBER	DESCRIPTION	PART NUMBER	DESCRIPTION
13-01412	Hex Nut Adapter - Superior	13-10071	CEMA C 35° Center Stand Clip
09-104200	CEMA B Rubber Disc 4" Dia. x 2" I.D.	13-10072	CEMA C 45° Center Stand Clip
09-105200	CEMA B Rubber Disc 5" Dia. x 2" I.D.	13-10073	CEMA D 20° Center Stand Clip
09-104225	CEMA C Rubber Disc 4" Dia. x 2 1/4" I.D.	13-10074	CEMA D 35° Center Stand Clip
09-105225	CEMA C Rubber Disc 5" Dia. x 2 1/4" I.D.	13-10075	CEMA D 45° Center Stand Clip
09-106225	CEMA C Rubber Disc 6" Dia. x 2 1/4" I.D.	13-10068	CEMA B & C End Stand Clip
09-105300	CEMA D Rubber Disc 5" Dia. x 3" I.D.	13-10069	CEMA D End Stand Clip
09-106300	CEMA D Rubber Disc 6" Dia. x 3" I.D.	03-02501	CEMA B Bearing and Seal Kit
09-106400	CEMA E Rubber Disc 6" Dia. x 4" I.D.	03-02502	CEMA C Bearing and Seal Kit
09-107400	CEMA E Rubber Disc 7" Dia. x 4" I.D.	03-02503	CEMA D Bearing and Seal Kit
13-10070	CEMA C 20° Center Stand Clip	03-02499	CEMA E Bearing and Seal Kit

81 SERIES CEMA C REGREASEABLE IDLERS

TROUGHING IDLERS (EQUAL LENGTH ROLLERS) – 4" & 5" DIAMETER

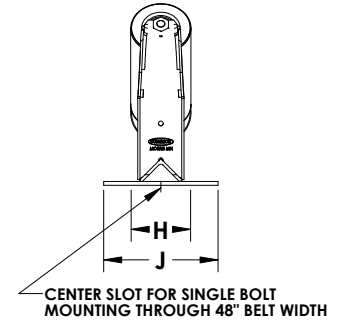
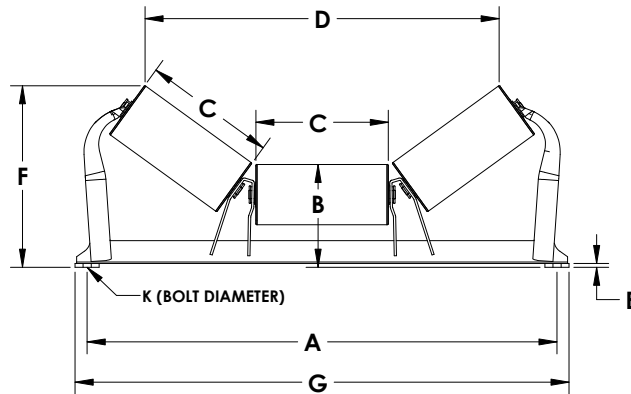

	PART NUMBER		BW	A	B		C	D		E	F		G	H*	J	K	WT (#)	
	4"	5"			4"	5"		4"	5"		4"	5"					4"	5"
20°	814-20E-18	815-20E-18	18	27	8	8-1/2	7-1/16	21-7/8	21-9/16	1/4	10-1/2	11	29	6	8	1/2	39	40
	814-20E-24	815-20E-24	24	33	8	8-1/2	9-1/16	27-5/8	27-5/16	5/16	11-3/16	11-11/16	35	6	9-1/2	5/8	40	44
	814-20E-30	815-20E-30	30	39	8	8-1/2	11-1/16	33-7/16	33-13/16	5/16	11-13/16	12-3/8	41	6	9-1/2	5/8	46	54
	814-20E-36	815-20E-36	36	45	8	8-1/2	13-1/16	39-3/16	38-13/16	5/16	12-5/8	13-1/16	47	6	9-1/2	5/8	53	62
	814-20E-42	815-20E-42	42	51	8-1/2	9	15-1/16	44-15/16	44-9/16	5/16	13-13/16	14-3/16	53	7-1/2	9-1/2	5/8	68	78
	814-20E-48	815-20E-48	48	57	8-1/2	9	17-1/16	50-11/16	50-3/8	5/16	14-3/8	14-7/8	59	7-1/2	9-1/2	5/8	76	87
35°	814-20E-54	815-20E-54	54	63	8-1/2	9	19-1/16	56-7/16	56-1/8	3/8	15-1/8	15-3/8	65-1/2	9	11	5/8	82	96
	814-20E-60	815-20E-60	60	69	8-1/2	9	21-1/16	62-3/16	61-7/8	3/8	15-3/4	16-3/16	71-1/2	9	11	5/8	88	104
	814-35E-18	815-35E-18	18	27	8	8-1/2	7-1/16	20	19-7/16	1/4	12-1/4	12-3/8	29	6	8	1/2	40	42
	814-35E-24	815-35E-24	24	33	8	8-1/2	9-1/16	25-5/16	24-11/16	5/16	13-3/8	13-13/16	35	6	9-1/2	5/8	42	47
	814-35E-30	815-35E-30	30	39	8	8-1/2	11-1/16	30-9/16	30	5/16	14-9/16	14-13/16	41	6	9-1/2	5/8	50	57
	814-35E-36	815-35E-36	36	45	8	8-1/2	13-1/16	35-13/16	35-1/4	5/16	15-11/16	16-1/8	47	6	9-1/2	5/8	56	64
45°	814-35E-42	815-35E-42	42	51	8-1/2	9	15-1/16	41-1/8	40-9/16	5/16	17-5/16	17-11/16	53	7-1/2	9-1/2	5/8	70	82
	814-35E-48	815-35E-48	48	57	8-1/2	9	17-1/16	46-3/8	45-13/16	5/16	18-7/16	18-7/8	59	7-1/2	9-1/2	5/8	78	90
	814-35E-54	815-35E-54	54	63	8-1/2	9	19-1/16	51-11/16	51-1/8	3/8	19-5/8	20	65-1/2	9	11	5/8	86	100
	814-35E-60	815-35E-60	60	69	8-1/2	9	21-1/16	56-15/16	56-3/8	3/8	20-3/4	21-3/16	71-1/2	9	11	5/8	D	107
	814-45E-18	815-45E-18	18	27	8	8-1/2	7-1/16	18-5/8	17-15/16	1/4	13-5/16	13-3/8	29	6	8	1/2	42	43
	814-45E-24	815-45E-24	24	33	8	8-1/2	9-1/16	23-1/2	22-3/4	5/16	14-11/16	15-1/16	35	6	9-1/2	5/8	44	49
45°	814-45E-30	815-45E-30	30	39	8	8-1/2	11-1/16	28-5/16	27-5/8	5/16	16-1/8	16-1/8	41	6	9-1/2	5/8	50	58
	814-45E-36	815-45E-36	36	45	8	8-1/2	13-1/16	33-1/8	32-7/16	5/16	17-9/16	17-13/16	47	6	9-1/2	5/8	57	65
	814-45E-42	815-45E-42	42	51	8-1/2	9	15-1/16	37-15/16	37-1/4	5/16	19-7/16	19-1/4	53	7-1/2	9-1/2	5/8	75	85
	814-45E-48	815-45E-48	48	57	8-1/2	9	17-1/16	42-13/16	42-1/16	5/16	20-13/16	21-3/16	59	7-1/2	9-1/2	5/8	81	92
	814-45E-54	815-45E-54	54	63	8-1/2	9	19-1/16	47-5/8	46-15/16	3/8	22-1/4	22-3/8	65-1/2	9	11	5/8	87	103
	814-45E-60	815-45E-60	60	69	8-1/2	9	21-1/16	52-7/16	51-3/4	3/8	23-11/16	24-1/16	71-1/2	9	11	5/8	95	111

* Recommended Bolt Pattern - See page 75 for minimum and maximum dimensions.

81 SERIES CEMA C REGREASEABLE IDLERS

TROUGHING IDLERS (EQUAL LENGTH ROLLERS) – 6" DIAMETER

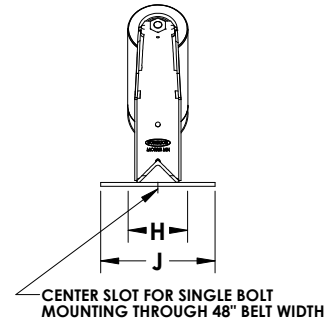
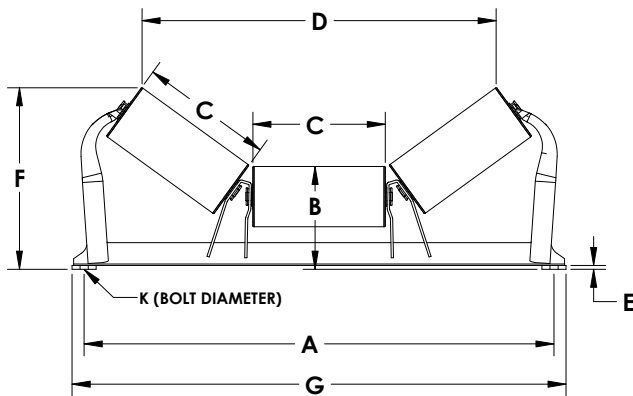

6" PART NUMBER	BW	A	B	C	D	E	F	G	H*	J	K	WT (#)
816-20E-18	18	27	9	7-1/16	21-3/16	1/4	11-7/16	29	6	8	1/2	42
816-20E-24	24	33	9	9-1/16	26-15/16	5/16	12-1/8	35	6	9-1/2	5/8	49
816-20E-30	30	39	9	11-1/16	32-3/4	5/16	12-7/8	41	6	9-1/2	5/8	59
816-20E-36	36	45	9	13-1/16	38-1/2	5/16	13-9/16	47	6	9-1/2	5/8	66
816-20E-42	42	51	9-1/2	15-1/16	44-1/4	5/16	14-11/16	53	7-1/2	9-1/2	5/8	84
816-20E-48	48	57	9-1/2	17-1/16	50	5/16	15-3/8	59	7-1/2	9-1/2	5/8	96
816-20E-54	54	63	9-1/2	19-1/16	55-3/4	3/8	16-1/8	65-1/2	9	11	5/8	114
816-20E-60	60	69	9-1/2	21-1/16	61-1/2	3/8	16-3/4	71-1/2	9	11	5/8	119
816-35E-18	18	27	9	7-1/16	18-7/8	1/4	13-1/16	29	6	8	1/2	44
816-35E-24	24	33	9	9-1/16	24-1/8	5/16	14-3/16	35	6	9-1/2	5/8	51
816-35E-30	30	39	9	11-1/16	29-7/16	5/16	15-3/8	41	6	9-1/2	5/8	61
816-35E-36	36	45	9	13-1/16	34-11/16	5/16	16-1/2	47	6	9-1/2	5/8	68
816-35E-42	42	51	9-1/2	15-1/16	40	5/16	18-1/8	53	7-1/2	9-1/2	5/8	86
816-35E-48	48	57	9-1/2	17-1/16	45-1/4	5/16	19-1/4	59	7-1/2	9-1/2	5/8	98
816-35E-54	54	63	9-1/2	19-1/16	50-1/2	3/8	20-7/16	65-1/2	9	11	5/8	118
816-35E-60	60	69	9-1/2	21-1/16	55-13/16	3/8	21-9/16	71-1/2	9	11	5/8	123
816-45E-18	18	27	9	7-1/16	17-1/4	1/4	14	29	6	8	1/2	45
816-45E-24	24	33	9	9-1/16	22-1/16	5/16	15-7/16	35	6	9-1/2	5/8	53
816-45E-30	30	39	9	11-1/16	26-7/8	5/16	16-7/8	41	6	9-1/2	5/8	63
816-45E-36	36	45	9	13-1/16	31-3/4	5/16	18-1/4	47	6	9-1/2	5/8	70
816-45E-42	42	51	9-1/2	15-1/16	36-9/16	5/16	20-1/8	53	7-1/2	9-1/2	5/8	91
816-45E-48	48	57	9-1/2	17-1/16	41-3/8	5/16	21-9/16	59	7-1/2	9-1/2	5/8	100
816-45E-54	54	63	9-1/2	19-1/16	46-3/16	3/8	23	65-1/2	9	11	5/8	122
816-45E-60	60	69	9-1/2	21-1/16	51	3/8	24-3/8	71-1/2	9	11	5/8	126

20°

35°

45°

* Recommended Bolt Pattern - See page 75 for minimum and maximum dimensions.

81 SERIES CEMA C REGREASEABLE IDLERS

RETURN IDLERS – 4", 5", & 6" DIAMETER

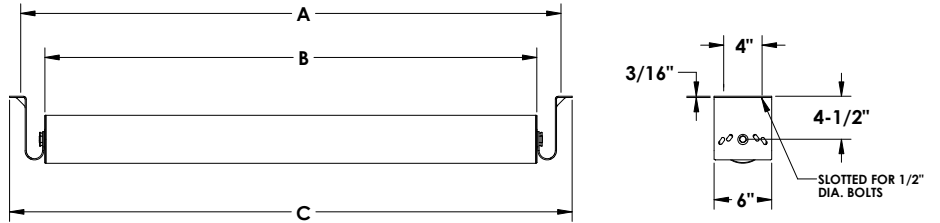

PART NUMBER			BW	A	B	C	WT (#)*		
4"	5"	6"					4"	5"	6"
814-RET-18	815-RET-18	816-RET-18	18	27	21-5/16	28-3/4	19	24	26
814-RET-24	815-RET-24	816-RET-24	24	33	27-5/16	34-3/4	22	29	33
814-RET-30	815-RET-30	816-RET-30	30	39	33-5/16	40-3/4	25	33	37
814-RET-36	815-RET-36	816-RET-36	36	45	39-5/16	46-3/4	31	37	43
814-RET-42	815-RET-42	816-RET-42	42	51	45-5/16	52-3/4	33	40	46
814-RET-48	815-RET-48	816-RET-48	48	57	51-5/16	58-3/4	35	46	52
814-RET-54 ✓	815-RET-54 ✓	816-RET-54 ✓	54	63	57-5/16	64-3/4	40	51	56
814-RET-60 ✓	815-RET-60 ✓	816-RET-60 ✓	60	69	63-5/16	70-3/4	42	55	60

FLAT IDLERS – 4", 5", & 6" DIAMETER

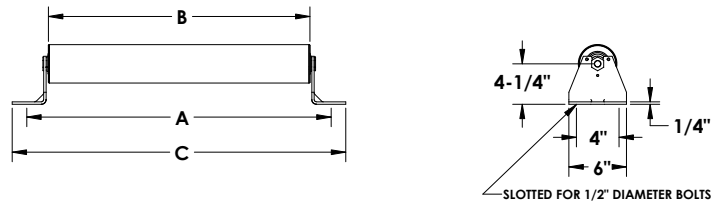

PART NUMBER			BW	A	B	C	WT (#)*		
4"	5"	6"					4"	5"	6"
814-FLT-18	815-FLT-18	816-FLT-18	18	27	21-5/16	28-3/4	19	24	26
814-FLT-24	815-FLT-24	816-FLT-24	24	33	27-5/16	34-3/4	22	29	33
814-FLT-30	815-FLT-30	816-FLT-30	30	39	33-5/16	40-3/4	25	33	37
814-FLT-36	815-FLT-36	816-FLT-36	36	45	39-5/16	46-3/4	31	37	43
814-FLT-42	815-FLT-42	816-FLT-42	42	51	45-5/16	52-3/4	33	40	46
814-FLT-48	815-FLT-48	816-FLT-48	48	57	51-5/16	58-3/4	35	46	52
814-FLT-54 ✓	815-FLT-54 ✓	816-FLT-54 ✓	54	63	57-5/16	64-3/4	40	51	56
814-FLT-60 ✓	815-FLT-60 ✓	816-FLT-60 ✓	60	69	63-5/16	70-3/4	42	55	60

Note: Return and Flat idlers are supplied with hold down kit for positive locking.

*All weights include brackets, individual bracket weights are listed on page 74 and 75. Brackets not included. ✓ Meets CEMA D specifications.

81 SERIES CEMA C REGREASEABLE IDLERS

RUBBER CUSHION IMPACT TROUGHING IDLERS – 4" & 5" DIAMETER

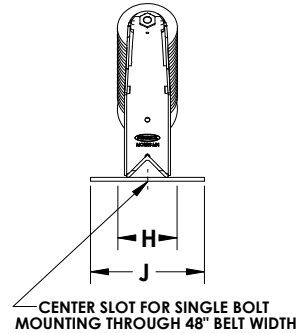
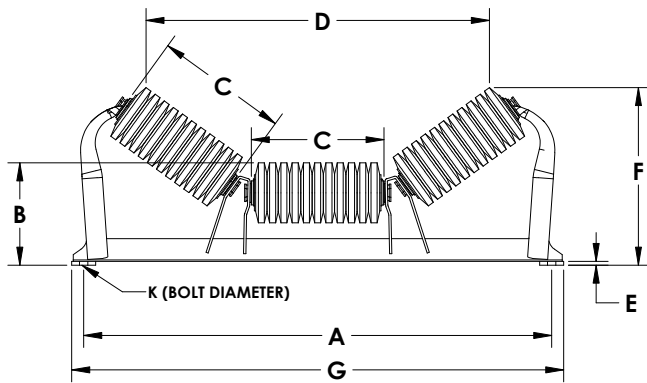

PART NUMBER		BW*	A	B		C	D		E	F		G	H**	J	K	WT (#)	
4"	5"			4"	5"		4"	5"		4"	5"					4"	5"
814-20EI-18	815-20EI-18	18	27	8	8-1/2	7-1/16	21-3/8	21-1/16	1/4	10-3/8	10-7/8	29	6	8	1/2	40	46
814-20EI-24	815-20EI-24	24	33	8	8-1/2	9-1/16	27-1/8	26-13/16	5/16	11-1/16	11-9/16	35	6	9-1/2	5/8	47	51
814-20EI-30	815-20EI-30	30	39	8	8-1/2	11-1/16	32-15/16	32-9/16	5/16	11-11/16	12-1/4	41	6	9-1/2	5/8	57	68
814-20EI-36	815-20EI-36	36	45	8	8-1/2	13-1/16	38-11/16	38-5/16	5/16	12-1/2	12-15/16	47	6	9-1/2	5/8	71	81
814-20EI-42	815-20EI-42	42	51	8-1/2	9	15-1/16	44-7/16	44-1/16	5/16	13-11/16	14-1/16	53	7-1/2	9-1/2	5/8	93	102
814-20EI-48	815-20EI-48	48	57	8-1/2	9	17-1/16	50-3/16	49-7/8	5/16	14-1/4	14-3/4	59	7-1/2	9-1/2	5/8	107	116
814-20EI-54	815-20EI-54	54	63	8-1/2	9	19-1/16	55-15/16	55-5/8	3/8	15	15 1/2	65-1/2	9	11	5/8	116	125
814-20EI-60	815-20EI-60	60	69	8-1/2	9	21-1/16	61-11/16	61-3/8	3/8	15-5/8	16-3/16	71-1/2	9	11	5/8	130	139
814-35EI-18	815-35EI-18	18	27	8	8-1/2	7-1/16	19-5/8	19-1/16	1/4	12-1/8	12-1/4	29	6	8	1/2	42	48
814-35EI-24	815-35EI-24	24	33	8	8-1/2	9-1/16	24-15/16	24-5/16	5/16	13-1/4	13-11/16	35	6	9-1/2	5/8	50	58
814-35EI-30	815-35EI-30	30	39	8	8-1/2	11-1/16	30-3/16	29-5/8	5/16	14-7/16	14-11/16	41	6	9-1/2	5/8	62	69
814-35EI-36	815-35EI-36	36	45	8	8-1/2	13-1/16	35-7/16	34-7/8	5/16	15-9/16	16	47	6	9-1/2	5/8	73	82
814-35EI-42	815-35EI-42	42	51	8-1/2	9	15-1/16	40-3/4	40-3/16	5/16	17-3/16	17-9/16	53	7-1/2	9-1/2	5/8	95	104
814-35EI-48	815-35EI-48	48	57	8-1/2	9	17-1/16	46	45-7/16	5/16	18-5/16	18-3/4	59	7-1/2	9-1/2	5/8	109	118
814-35EI-54	815-35EI-54	54	63	8-1/2	9	19-1/16	51-5/16	50-3/4	3/8	19-1/2	19-7/8	65-1/2	9	11	5/8	118	127
814-35EI-60	815-35EI-60	60	69	8-1/2	9	21-1/16	56-9/16	56	3/8	20-5/8	21-1/16	71-1/2	9	11	5/8	133	142
814-45EI-18	815-45EI-18	18	27	8	8-1/2	7-1/16	18-1/4	17-9/16	1/4	13-1/8	13-7/16	29	6	8	1/2	44	50
814-45EI-24	815-45EI-24	24	33	8	8-1/2	9-1/16	23-1/8	22-3/8	5/16	14-1/2	14-7/8	35	6	9-1/2	5/8	52	61
814-45EI-30	815-45EI-30	30	39	8	8-1/2	11-1/16	27-15/16	27-1/4	5/16	15-15/16	16-5/16	41	6	9-1/2	5/8	62	72
814-45EI-36	815-45EI-36	36	45	8	8-1/2	13-1/16	32-3/4	32-3/4	5/16	17-3/8	17-3/4	47	6	9-1/2	5/8	75	84
814-45EI-42	815-45EI-42	42	51	8-1/2	9	15-1/16	37-9/16	36-7/8	5/16	19-1/4	19-9/16	53	7-1/2	9-1/2	5/8	97	106
814-45EI-48	815-45EI-48	48	57	8-1/2	9	17-1/16	42-7/16	41-11/16	5/16	20-5/8	21	59	7-1/2	9-1/2	5/8	111	120
814-45EI-54	815-45EI-54	54	63	8-1/2	9	19-1/16	47-1/4	46-9/16	3/8	22-1/16	22-7/16	65-1/2	9	11	5/8	121	130
814-45EI-60	815-45EI-60	60	69	8-1/2	9	21-1/16	52-1/16	51-3/8	3/8	23-1/2	23-7/8	71-1/2	9	11	5/8	136	145

20°

35°

45°

* Belt Width (Reinforcing on 36" BW - 60" BW Impact Frame).

** Recommended Bolt Pattern - See page 75 for minimum and maximum dimensions.

81 SERIES CEMA C REGREASEABLE IDLERS

RUBBER CUSHION IMPACT TROUGHING IDLERS – 6" DIAMETER

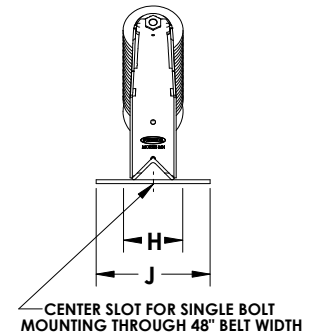
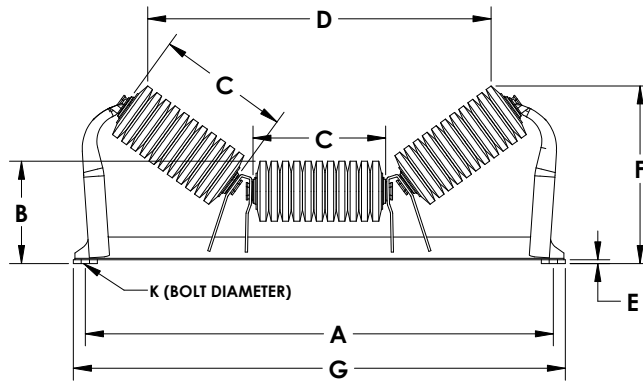

	6" PART NUMBER	BW*	A	B	C	D	E	F	G	H**	J	K	WT (#)
20°	816-20EI-18	18	27	9	7-1/16	20-11/16	1/4	11-5/16	29	6	8	1/2	49
	816-20EI-24	24	33	9	9-1/16	26-7/16	5/16	12	35	6	9-1/2	5/8	62
	816-20EI-30	30	39	9	11-1/16	32-1/4	5/16	12-3/4	41	6	9-1/2	5/8	74
	816-20EI-36	36	45	9	13-1/16	38	5/16	13-7/16	47	6	9-1/2	5/8	90
	816-20EI-42	42	51	9-1/2	15-1/16	43-3/4	5/16	14-9/16	53	7-1/2	9-1/2	5/8	111
	816-20EI-48	48	57	9-1/2	17-1/16	49-1/2	5/16	15-1/4	59	7-1/2	9-1/2	5/8	126
	816-20EI-54	54	63	9-1/2	19-1/16	55-1/4	3/8	15-15/16	65-1/2	9	11	5/8	136
	816-20EI-60	60	69	9-1/2	21-1/16	61	3/8	16-5/8	71-1/2	9	11	5/8	146
35°	816-35EI-18	18	27	9	7-1/16	18-1/2	1/4	12-15/16	29	6	8	1/2	51
	816-35EI-24	24	33	9	9-1/16	23-3/4	5/16	14-1/16	35	6	9-1/2	5/8	65
	816-35EI-30	30	39	9	11-1/16	29-1/16	5/16	15-1/4	41	6	9-1/2	5/8	77
	816-35EI-36	36	45	9	13-1/16	34-5/16	5/16	16-3/8	47	6	9-1/2	5/8	92
	816-35EI-42	42	51	9-1/2	15-1/16	39-5/8	5/16	18	53	7-1/2	9-1/2	5/8	113
	816-35EI-48	48	57	9-1/2	17-1/16	44-7/8	5/16	19-1/8	59	7-1/2	9-1/2	5/8	128
	816-35EI-54	54	63	9-1/2	19-1/16	50-1/8	3/8	20-5/16	65-1/2	9	11	5/8	139
	816-35EI-60	60	69	9-1/2	21-1/16	55-7/16	3/8	21-7/16	71-1/2	9	11	5/8	150
45°	816-45EI-18	18	27	9	7-1/16	16-7/8	1/4	13-13/16	29	6	8	1/2	53
	816-45EI-24	24	33	9	9-1/16	21-11/16	5/16	15-1/4	35	6	9-1/2	5/8	67
	816-45EI-30	30	39	9	11-1/16	26-1/2	5/16	16-11/16	41	6	9-1/2	5/8	78
	816-45EI-36	36	45	9	13-1/16	32-1/16	5/16	18-1/16	47	6	9-1/2	5/8	94
	816-45EI-42	42	51	9-1/2	15-1/16	36-3/16	5/16	19-15/16	53	7-1/2	9-1/2	5/8	115
	816-45EI-48	48	57	9-1/2	17-1/16	41	5/16	21-3/8	59	7-1/2	9-1/2	5/8	131
	816-45EI-54	54	63	9-1/2	19-1/16	45-13/16	3/8	22-13/16	65-1/2	9	11	5/8	142
	816-45EI-60	60	69	9-1/2	21-1/16	50-9/16	3/8	24-3/16	71-1/2	9	11	5/8	153

* Belt Width (Reinforcing on 36" BW - 60" BW Impact Frame).

** Recommended Bolt Pattern - See page 75 for minimum and maximum dimensions.

81 SERIES CEMA C REGREASEABLE IDLERS

RUBBER CUSHION RETURN IDLERS – 4", 5", & 6" DIAMETER

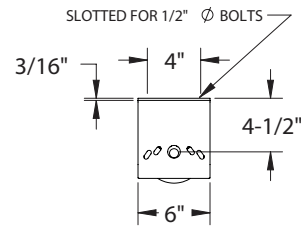
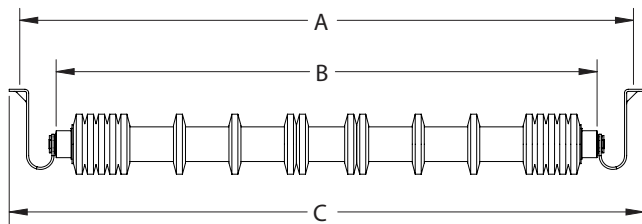

PART NUMBER			BW*	A	B	C	WT (#)**		
4"	5"	6"					4"	5"	6"
814-RETI-18	815-RETI-18	816-RETI-18	18	27	21-5/16	28-3/4	19	24	26
814-RETI-24	815-RETI-24	816-RETI-24	24	33	27-5/16	34-3/4	22	29	33
814-RETI-30	815-RETI-30	816-RETI-30	30	39	33-5/16	40-3/4	25	33	37
814-RETI-36	815-RETI-36	816-RETI-36	36	45	39-5/16	46-3/4	31	37	43
814-RETI-42	815-RETI-42	816-RETI-42	42	51	45-5/16	52-3/4	33	40	46
814-RETI-48	815-RETI-48	816-RETI-48	48	57	51-5/16	58-3/4	35	46	52
814-RETI-54 ✓	815-RETI-54 ✓	816-RETI-54 ✓	54	63	57-5/16	64-3/4	40	51	56
814-RETI-60 ✓	815-RETI-60 ✓	816-RETI-60 ✓	60	69	63-5/16	70-3/4	42	55	60

RUBBER CUSHION FLAT IDLERS – 4", 5", & 6" DIAMETER

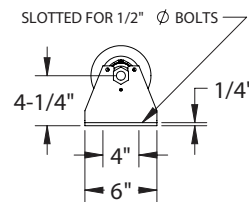
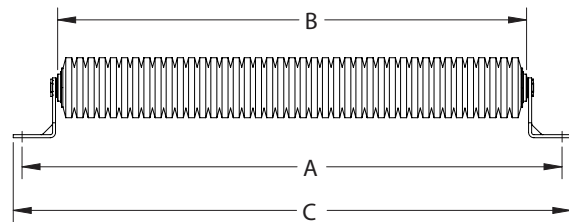

PART NUMBER			BW	A	B	C	WT (#)**		
4"	5"	6"					4"	5"	6"
814-FLTI-18	815-FLTI-18	816-FLTI-18	18	27	21-5/16	28-3/4	36	38	39
814-FLTI-24	815-FLTI-24	816-FLTI-24	24	33	27-5/16	34-3/4	41	43	46
814-FLTI-30	815-FLTI-30	816-FLTI-30	30	39	33-5/16	40-3/4	47	49	52
814-FLTI-36	815-FLTI-36	816-FLTI-36	36	45	39-5/16	46-3/4	52	55	61
814-FLTI-42	815-FLTI-42	816-FLTI-42	42	51	45-5/16	52-3/4	60	63	69
814-FLTI-48	815-FLTI-48	816-FLTI-48	48	57	51-5/16	58-3/4	66	70	76
814-FLTI-54 ✓	815-FLTI-54 ✓	816-FLTI-54 ✓	54	63	57-5/16	64-3/4	72	76	84
814-FLTI-60 ✓	815-FLTI-60 ✓	816-FLTI-60 ✓	60	69	63-5/16	70-3/4	78	82	93

* Belt Width (Reinforcing on 36" BW - 60" BW Impact Frame).

**All weights include brackets, individual bracket weights are listed on page 74 and 75. Brackets not included. ✓ Meets CEMA D specifications.

Note: Return and Flat idlers are supplied with hold down kit for positive locking.

81 SERIES CEMA C REGREASEABLE IDLERS

SELF-ALIGNING TROUGHING IDLER – 4" & 5" DIAMETER

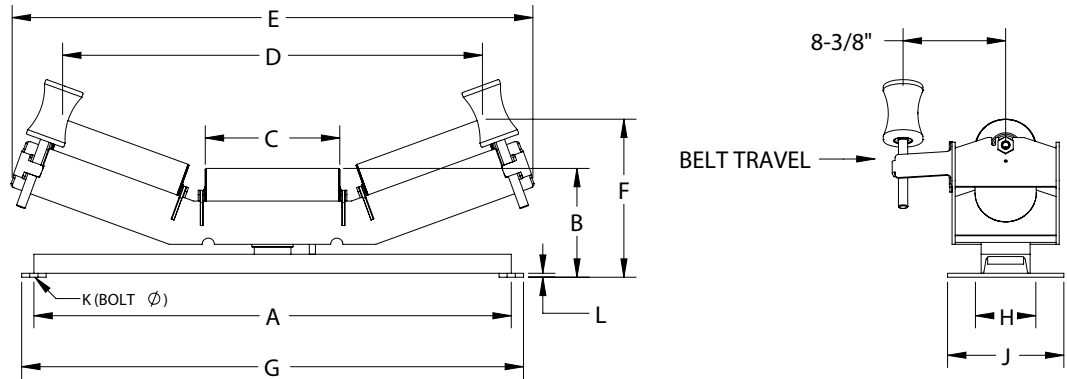

	PART NUMBER		BW	B		C	D		E	F		G	H*	J	K	L	WT (#)		
	4"	5"		4"	5"		4"	5"		4"	5"						4"	5"	4"
20°	814-20EA-18	815-20EA-18	18	27	8-1/4	8-3/4	7-1/16	23-1/4	22-15/16	30-15/16	10-15/16	11-7/16	29	6	8	1/2	3/16	70	76
	814-20EA-24	815-20EA-24	24	33	8-1/4	8-7/8	9-1/16	29	28-11/16	36-5/89	11-3/4	12-1/4	35	6	9-1/2	1/2	5/16	79	88
	814-20EA-30	815-20EA-30	30	39	8-3/8	8-7/8	11-1/16	34-3/4	34-7/16	42-7/16	12-7/16	12-15/16	41	6	9-1/2	1/2	5/16	90	99
	814-20EA-36	815-20EA-36	36	45	8-7/8	8-7/8	13-1/16	40-1/2	40-3/16	48-3/16	13-1/8	13-5/8	47	6	9-1/2	1/2	5/16	99	109
	814-20EA-42	815-20EA-42	42	51	8-7/8	9-3/8	15-1/16	46-1/8	45-13/16	53-13/16	14-5/16	14-13/16	53	7-1/2	9-1/2	5/8	5/16	113	124
	814-20EA-48	815-20EA-48	48	57	8-7/8	9-3/8	17-1/16	51-7/8	51-9/16	59-9/16	15	15-1/2	59	7-1/2	9-1/2	5/8	5/16	122	135
35°	814-20EA-54	815-20EA-54	54	63	8-7/8	9-3/8	19-1/16	57-5/8	57-5/16	65-5/16	15-11/16	16-3/16	65	9	11	5/8	5/16	132	146
	814-20EA-60	815-20EA-60	60	69	8-15/16	9-7/16	21-1/16	63-3/8	63-1/16	71-1/16	16-7/16	16-15/16	71-1/2	9	11	5/8	3/8	145	160
	814-35EA-18	815-35EA-18	18	27	8-1/4	8-11/16	7-1/16	23-1/4	19-7/8	30-7/16	10-15/16	12-15/16	29	6	8	1/2	3/16	70	77
	814-35EA-24	815-35EA-24	24	33	8-3/8	8-13/16	9-1/16	29	25-1/8	35-11/16	11-3/4	14-3/16	35	6	9-1/2	1/2	5/16	81	89
	814-35EA-30	815-35EA-30	30	39	8-3/8	8-13/16	11-1/16	34-3/4	30-3/8	41	12-7/16	15-3/8	41	6	9-1/2	1/2	5/16	90	99
	814-35EA-36	815-35EA-36	36	45	8-3/8	8-13/16	13-1/16	40-1/2	35-11/16	46-1/4	13-1/8	16-1/2	47	6	9-1/2	1/2	5/16	99	110
45°	814-35EA-42	815-35EA-42	42	51	8-7/8	9-5/16	15-1/16	46-1/8	40-5/8	51-3/16	14-5/16	18-1/8	53	7-1/2	9-1/2	5/8	5/16	113	125
	814-35EA-48	815-35EA-48	48	57	8-7/8	9-5/16	17-1/16	51-7/8	45-15/16	56-1/2	15	19-5/16	59	7-1/2	9-1/2	5/8	5/16	122	136
	814-35EA-54	815-35EA-54	54	63	8-7/8	9-5/16	19-1/16	57-5/8	51-3/16	61-3/4	15-11/16	20-7/16	65	9	11	5/8	5/16	132	147
	814-35EA-60	815-35EA-60	60	69	8-15/16	9-3/8	21-1/16	63-3/8	56-7/16	67-1/16	16-7/16	21-11/16	71-1/2	9	11	5/8	3/8	145	161
	814-45EA-18	815-45EA-18	18	27	8-3/16	8-11/16	7-1/16	19-9/16	18-7/8	30-13/16	13-3/8	13-3/4	29	6	8	1/2	3/16	72	78
	814-45EA-24	815-45EA-24	24	33	8-5/16	8-13/16	9-1/16	24-3/8	23-11/16	35-5/8	14-15/16	15-5/16	35	6	9-1/2	1/2	5/16	82	90
45°	814-45EA-30	815-45EA-30	30	39	8-5/16	8-13/16	11-1/16	29-3/16	28-9/16	40-7/16	16-3/8	16-11/16	41	6	9-1/2	1/2	5/16	92	101
	814-45EA-36	815-45EA-36	36	45	8-5/16	8-13/16	13-1/16	34	33-3/8	45-1/4	17-3/4	18-1/8	47	6	9-1/2	1/2	5/16	101	111
	814-45EA-42	815-45EA-42	42	51	8-13/16	9-5/16	15-1/16	38-7/16	37-13/16	49-11/16	19-11/16	20	53	7-1/2	9-1/2	5/8	5/16	115	126
	814-45EA-48	815-45EA-48	48	57	8-13/16	9-5/16	17-1/16	43-1/4	42-5/8	54-1/2	21-1/16	21-7/16	59	7-1/2	9-1/2	5/8	5/16	125	137
	814-45EA-54	815-45EA-54	54	63	8-13/16	9-5/16	19-1/16	48-1/8	47-7/16	59-3/8	22-1/2	22-7/8	65	9	11	5/8	5/16	134	149
	814-45EA-60	815-45EA-60	60	69	8-7/8	9-3/8	21-1/16	52-15/16	52-1/4	64-3/16	24	24-5/16	71-1/2	9	11	5/8	3/8	147	162

Note: Also available in bi-directional, designated by (BA).

* Recommended Bolt Pattern - See page 75 for minimum and maximum dimensions.

81 SERIES CEMA C REGREASEABLE IDLERS

SELF-ALIGNING TROUGHING IDLER – 6" DIAMETER

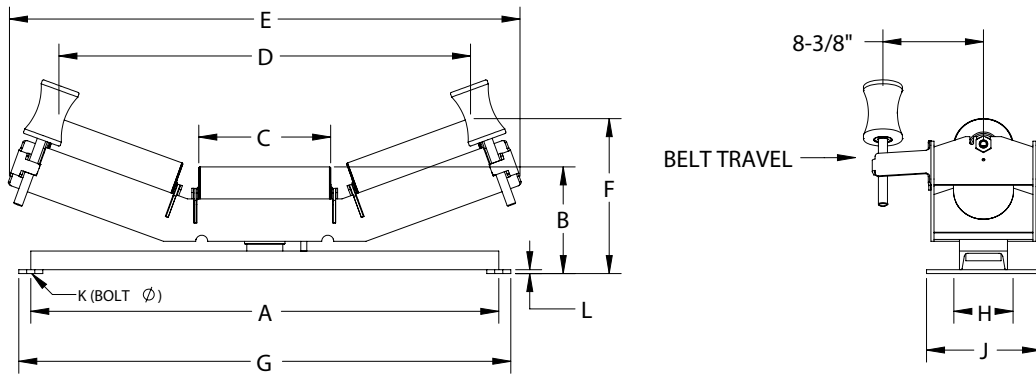

6" PART NUMBER	BW	A	B	C	D	E	F	G	H	J	K	L	WT (#)
816-20EA-18	18	27	9 1/4	7-1/16	22-9/16	30-15/16	11-7/8	29	6	8	1/2	3/16	83
816-20EA-24	24	33	9-3/8	9-1/16	28-5/16	36-11/16	12-11/16	35	6	9-1/2	1/2	5/16	98
816-20EA-30	30	39	9-3/8	11-1/16	34-1/8	42-7/16	13-3/8	41	6	9-1/2	1/2	5/16	111
816-20EA-36	36	45	9-3/8	13-1/16	39-7/8	48-3/16	14 1/16	47	6	9-1/2	1/2	5/16	123
816-20EA-42	42	51	9-7/8	15-1/16	45-7/16	53-13/16	15-1/4	53	7-1/2	9-1/2	5/8	5/16	140
816-20EA-48	48	57	9-7/8	17-1/16	51-3/16	59-9/16	15-15/16	59	7-1/2	9-1/2	5/8	5/16	153
816-20EA-54	54	63	9-7/8	19-1/16	56-15/16	65-5/16	16-5/8	65	9	11	5/8	5/16	166
816-20EA-60	60	69	9-15/16	21-1/16	62-11/16	71-1/16	17-3/8	71-1/2	9	11	5/8	3/8	182
816-35EA-18	18	27	9-3/16	7-1/16	19-1/4	30-7/16	13-5/16	29	6	8	1/2	3/16	84
816-35EA-24	24	33	9-5/16	9-1/16	24-9/16	35-11/16	14-5/8	35	6	9-1/2	1/2	5/16	99
816-35EA-30	30	39	9-5/16	11-1/16	29-13/16	41	15-3/4	41	6	9-1/2	1/2	5/16	111
816-35EA-36	36	45	9-5/16	13-1/16	35-1/8	46-1/4	16-15/16	47	6	9-1/2	1/2	5/16	124
816-35EA-42	42	51	9-13/16	15-1/16	40-1/16	51-3/16	18-9/16	53	7-1/2	9-1/2	5/8	5/16	141
816-35EA-48	48	57	9-13/16	17-1/16	45-3/8	56-1/2	19-11/16	59	7-1/2	9-1/2	5/8	5/16	154
816-35EA-54	54	63	9-13/16	19-1/16	50-5/8	61-3/4	20-7/8	65	9	11	5/8	5/16	167
816-35EA-60	60	69	9-7/8	21-1/16	55-7/8	67-1/16	22-1/16	71-1/2	9	11	5/8	3/8	183
816-45EA-18	18	27	9-3/16	7-1/16	18-3/16	30-13/16	14-1/16	29	6	8	1/2	3/16	85
816-45EA-24	24	33	9-5/16	9-1/16	23	35-5/8	15-5/8	35	6	9-1/2	1/2	5/16	100
816-45EA-30	30	39	9-5/16	11-1/16	27-7/8	40-7/16	17-1/16	41	6	9-1/2	1/2	5/16	113
816-45EA-36	36	45	9-5/16	13-1/16	32-11/16	45-1/4	18-7/16	47	6	9-1/2	1/2	5/16	125
816-45EA-42	42	51	9-13/16	15-1/16	37-1/16	49-11/16	20-3/8	53	7-1/2	9-1/2	5/8	5/16	142
816-45EA-48	48	57	9-13/16	17-1/16	41-15/16	54-1/2	21-13/16	59	7-1/2	9-1/2	5/8	5/16	156
816-45EA-54	54	63	9-13/16	19-1/16	46-3/4	59-3/8	23-3/16	65	9	11	5/8	5/16	168
816-45EA-60	60	69	9-7/8	21-1/16	51-9/16	64-3/16	24-11/16	71-1/2	9	11	5/8	3/8	184

20°
35°
45°

SELF-ALIGNING RETURN IDLERS – 4", 5", & 6" DIAMETER

PART NUMBER			BW	A	B	C	D	WT (#)		
4"	5"	6"						4"	5"	6"
814-RETA-18	815-RETA-18	816-RETA-18	18	27	21-5/16	29-3/4	23-5/8	75	76	79
814-RETA-24	815-RETA-24	816-RETA-24	24	33	27-5/16	35-3/4	29-5/8	82	84	88
814-RETA-30	815-RETA-30	816-RETA-30	30	39	33-5/16	41-3/4	35-5/8	102	111	114
814-RETA-36	815-RETA-36	816-RETA-36	36	45	39-5/16	47-3/4	41-5/8	112	117	135
814-RETA-42	815-RETA-42	816-RETA-42	42	51	45-5/16	53-3/4	47-5/8	144	148	150
814-RETA-48	815-RETA-48	816-RETA-48	48	57	51-5/16	59-3/4	53-5/8	152	157	159
814-RETA-54 ✓	815-RETA-54 ✓	816-RETA-54 ✓	54	63	57-5/16	65-3/4	59-5/8	167	170	173
814-RETA-60 ✓	815-RETA-60 ✓	816-RETA-60 ✓	60	69	63-5/16	71-3/4	65-5/8	182	185	187

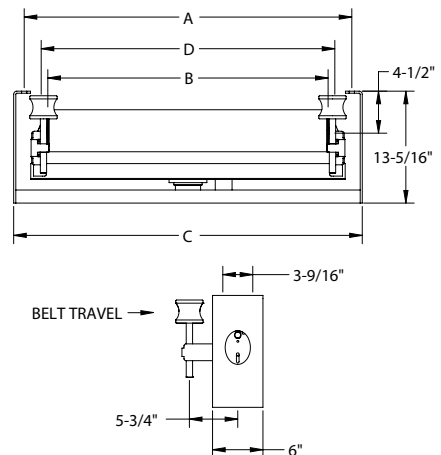

Note: Also available in bi-directional. Designated by (BA). Brackets not included. ✓ Meets CEMA D specifications.

81 SERIES CEMA C REGREASEABLE IDLERS

TROUGHING IDLERS (UNEQUAL LENGTH ROLLS) – 4", 5", & 6" DIAMETER

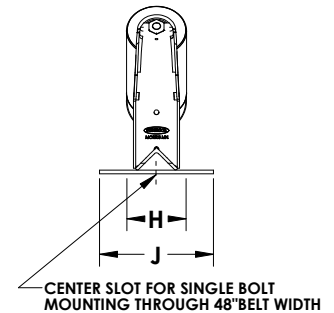
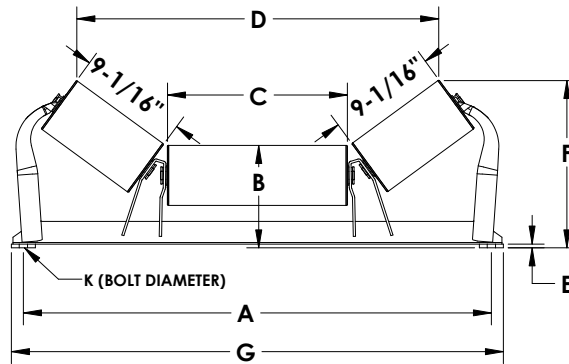

	4" PART NUMBER	BW*	A		C	D	E	F	G	H***	J	K	WT (#)
			35°	45°									
35°	814-35U-30	30	39	8	15-1/16	31-5/16	5/16	13-3/8	41	6	9-1/2	5/8	50
	814-35U-36	36	45	8	21-5/16	37-5/8	5/16	13-3/8	47	6	9-1/2	5/8	57
	814-35U-42	42	51	8-1/2	27-5/16	43-5/8	5/16	13-7/8	53	7-1/2	9-1/2	5/8	71
	814-35U-48	48	57	8-1/2	33-5/16	49-5/8	5/16	13-7/8	59	7-1/2	9-1/2	5/8	74
	814-35U-54	54	63	8-1/2	39-5/16	55-5/8	3/8	13-7/8	65-1/2	9	11	5/8	78
	814-35U-60	60	69	8	45-5/16	61-5/8	3/8	13-7/8	71-1/2	9	11	5/8	81
45°	814-45U-30	30	39	8	15-1/16	29-1/2	5/16	14-3/4	41	6	9-1/2	5/8	52
	814-45U-36	36	45	8-1/2	21-5/16	35-13/16	5/16	14-3/4	47	6	9-1/2	5/8	59
	814-45U-42	42	51	8-1/2	27-5/16	41-13/16	5/16	15-3/16	53	7-1/2	9-1/2	5/8	77
	814-45U-48	48	57	8-1/2	33-5/16	47-13/16	5/16	15-3/16	59	7-1/2	9-1/2	5/8	81
	814-45U-54	54	63	8-1/2	39-5/16	53-13/16	3/8	15-3/16	65-1/2	9	11	5/8	83
	814-45U-60	60	69	9	45-5/16	59-13/16	3/8	15-3/16	71-1/2	9	11	5/8	86

	PART NUMBER		BW*	A	B		C	D	E	F		G	H***	J	K	WT (#)	
	5"	6"			5"	6"				5"	6"					5"	6"
35°	815-35U-30	816-35U-30	30	39	8	9	15-1/16	31-5/16	5/16	13-3/8	14-1/4	41	6	9-1/2	5/8	50	61
	815-35U-36	816-35U-36	36	45	8	9	21-5/16	37-5/8	5/16	13-3/8	14-1/4	47	6	9-1/2	5/8	57	72
	815-35U-42	816-35U-42	42	51	8-1/2	9-1/2	27-5/16	43-5/8	5/16	13-7/8	14-11/16	53	7-1/2	9-1/2	5/8	71	86
	815-35U-48	816-35U-48	48	57	8-1/2	9-1/2	33-5/16	49-5/8	5/16	13-7/8	14-11/16	59	7-1/2	9-1/2	5/8	74	96
	815-35U-54	816-35U-54	54	63	8-1/2	9-1/2	39-5/16	55-5/8	3/8	13-7/8	14-11/16	65-1/2	9	11	5/8	78	102
	815-35U-60	816-35U-60	60	69	8	9-1/2	45-5/16	61-5/8	3/8	13-7/8	14-11/16	71-1/2	9	11	5/8	81	107
45°	815-45U-30	816-45U-30	30	39	8	9	15-1/16	29-1/2	5/16	14-3/4	15-7/16	41	6	9-1/2	5/8	52	63
	815-45U-36	816-45U-36	36	45	8-1/2	9	21-5/16	35-13/16	5/16	14-3/4	15-7/16	47	6	9-1/2	5/8	59	75
	815-45U-42	816-45U-42	42	51	8-1/2	9-1/2	27-5/16	41-13/16	5/16	15-3/16	15-7/8	53	7-1/2	9-1/2	5/8	77	92
	815-45U-48	816-45U-48	48	57	8-1/2	9-1/2	33-5/16	47-13/16	5/16	15-3/16	15-7/8	59	7-1/2	9-1/2	5/8	81	98
	815-45U-54	816-45U-54	54	63	8-1/2	9-1/2	39-5/16	53-13/16	3/8	15-3/16	15-15/16	65-1/2	9	11	5/8	83	104
	815-45U-60	816-45U-60	60	69	9	9-1/2	45-5/16	59-13/16	3/8	15-3/16	15-15/16	71-1/2	9	11	5/8	86	109

* Belt Width (Reinforcing on 36" BW - 60" BW Impact Frame only).

** Also available in rubber cushioned roller. Designated by (UI).

*** Recommended Bolt Pattern - See page 75 for minimum and maximum dimensions.

81 SERIES CEMA C REGREASEABLE IDLERS

FEEDER / PICKING TROUGHING IDLERS – 4", 5", & 6" DIAMETER

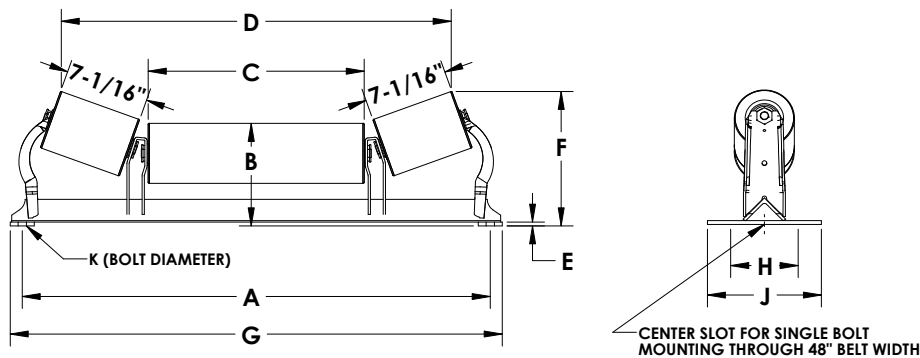

4" PART NUMBER	BW*	A	B	C	D	E	F	G	H**	J	K	WT (#)
814-20P-24	24	33	8	12-1/16	26-25/32	5/16	10-9/16	35	6	9-1/2	5/8	38
814-20P-30	30	39	8	18-1/16	32-7/8	5/16	10-9/16	41	6	9-1/2	5/8	45
814-20P-36	36	45	8	24-1/16	38-7/8	5/16	10-9/16	47	6	9-1/2	5/8	52
814-20P-42	42	51	8-1/2	30-1/16	44-7/8	5/16	11	53	7-1/2	9-1/2	5/8	70
814-20P-48	48	57	8-1/2	36-1/16	50-7/8	5/16	11	59	7-1/2	9-1/2	5/8	79
814-20P-54	54	63	8-1/2	42-1/16	56-7/8	3/8	11	65-1/2	9	11	5/8	87
814-20P-60	60	69	8-1/2	48-1/16	62-7/8	3/8	11	71-1/2	9	11	5/8	94

5" PART NUMBER	BW*	A	B	C	D	E	F	G	H**	J	K	WT (#)
815-20P-24	24	33	8-1/2	12-1/16	26-7/16	5/16	11	35	6	9-1/2	5/8	46
815-20P-30	30	39	8-1/2	18-1/16	32-9/16	5/16	11	41	6	9-1/2	5/8	53
815-20P-36	36	45	8-1/2	24-1/16	38-9/16	5/16	11	47	6	9-1/2	5/8	57
815-20P-42	42	51	9	30-1/16	44-9/16	5/16	11-1/2	53	7-1/2	9-1/2	5/8	75
815-20P-48	48	57	9	36-1/16	50-9/16	5/16	11-1/2	59	7-1/2	9-1/2	5/8	83
815-20P-54	54	63	9	42-1/16	56-9/16	3/8	11-1/2	65-1/2	9	11	5/8	95
815-20P-60	60	69	9	48-1/16	62-9/16	3/8	11-1/2	71-1/2	9	11	5/8	102

6" PART NUMBER	BW*	A	B	C	D	E	F	G	H**	J	K	WT (#)
816-20P-24	24	33	9	12-1/16	26-3/32	5/16	11-1/2	35	6	9-1/2	5/8	52
816-20P-30	30	39	9	18-1/16	32-3/16	5/16	11-1/2	41	6	9-1/2	5/8	59
816-20P-36	36	45	9	24-1/16	38-3/16	5/16	11-1/2	47	6	9-1/2	5/8	68
816-20P-42	42	51	9-1/2	30-1/16	44-3/16	5/16	11-15/16	53	7-1/2	9-1/2	5/8	85
816-20P-48	48	57	9-1/2	36-1/16	50-3/16	5/16	11-15/16	59	7-1/2	9-1/2	5/8	90
816-20P-54	54	63	9-1/2	42-1/16	56-3/16	3/8	11-15/16	65-1/2	9	11	5/8	106
816-20P-60	60	69	9-1/2	48-1/16	62-3/16	3/8	11-15/16	71-1/2	9	11	5/8	115

* Belt Width (Reinforcing on 36" BW - 60" BW Impact Frame only).

** Recommended Bolting Pattern - See page 68 for minimum and maximum dimensions.

Note: Also available in rubber cushioned roller. Designated by PI. Use PCI if you require impact rolls only in the center.

81 SERIES CEMA C REGREASEABLE IDLERS

OFFSET CENTER ROLL IDLER – 5" & 6" DIAMETER

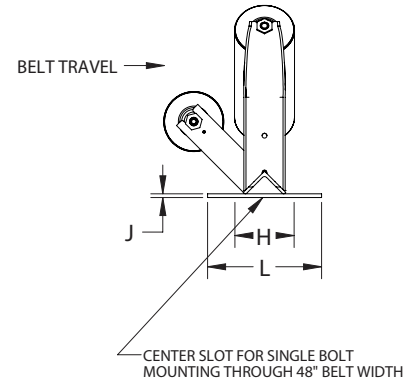
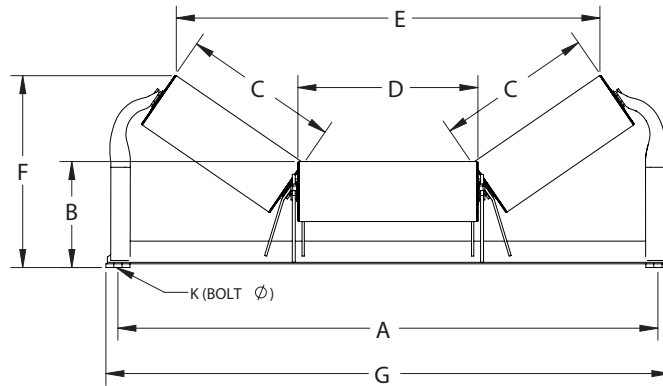

	PART NUMBER		BW	A	B		C	D	E		F		G	H	J	K*	L	WT (#)	
	5"	6"			5"	6"			5"	6"	5"	6"						5"	6"
	5"	6"			5"	6"			5"	6"	5"	6"						5"	6"
20°	815-20GO-18	816-20GO-18	18	27	8-1/2	9	7-1/16	9-1/6	20-1/16	19-3/4	11	11-7/16	29	1/2	1/4	6	8	43	50
	815-20GO-24	816-20GO-24	24	33	8-1/2	9	9-1/16	11-1/16	25-13/16	25-1/2	11-11/16	12-1/8	35	5/8	5/16	6	9-1/2	50	58
	815-20GO-30	816-20GO-30	30	39	8-1/2	9	11-1/16	13-1/6	31-5/8	31-1/4	12-3/8	12-7/8	41	5/8	5/16	6	9-1/2	60	66
	815-20GO-36	816-20GO-36	36	45	8-1/2	9	13-1/16	15-1/6	37-3/8	37	13-1/16	13-9/16	47	5/8	5/16	6	9-1/2	64	75
	815-20GO-42	816-20GO-42	42	51	9	9-1/2	15-1/16	17-1/16	43-1/8	42-3/4	14-3/16	14-11/16	53	5/8	5/16	7-1/2	9-1/2	82	92
	815-20GO-48	816-20GO-48	48	57	9	9-1/2	17-1/16	19-1/16	48-7/8	48-9/16	14-7/8	15-3/8	59	5/8	5/16	7-1/2	9-1/2	91	98
	815-20GO-54	816-20GO-54	54	63	9	9-1/2	19-1/16	21-1/16	54-5/8	54-5/16	15-5/8	16-1/16	65-1/2	5/8	3/8	9	11	101	131
815-20GO-60	816-20GO-60	60	69	9	9-1/2	21-1/16	23-5/16	60-3/8	60-1/16	16-5/16	16-3/4	71-1/2	5/8	3/8	9	11	125	139	
35°	815-35GO-18	816-35GO-18	18	27	8-1/2	9	7-1/16	9-1/6	17-3/4	17-1/8	12-5/8	13-1/16	29	1/2	1/4	6	8	44	51
	815-35GO-24	816-35GO-24	24	33	8-1/2	9	9-1/16	11-1/16	23	22-7/16	13-13/16	14-3/16	35	5/8	5/16	6	9-1/2	56	60
	815-35GO-30	816-35GO-30	30	39	8-1/2	9	11-1/16	13-1/6	28-5/16	27-11/16	14-15/16	15-5/8	41	5/8	5/16	6	9-1/2	63	69
	815-35GO-36	816-35GO-36	36	45	8-1/2	9	13-1/16	15-1/6	33-9/16	33	16-1/8	16-1/2	47	5/8	5/16	6	9-1/2	69	81
	815-35GO-42	816-35GO-42	42	51	9	9-1/2	15-1/16	17-1/16	38-13/16	38-1/4	17-11/16	18-1/8	53	5/8	5/16	7-1/2	9-1/2	85	94
	815-35GO-48	816-35GO-48	48	57	9	9-1/2	17-1/16	19-1/16	44-1/8	43-9/16	18-7/8	19-1/4	59	5/8	5/16	7-1/2	9-1/2	97	105
	815-35GO-54	816-35GO-54	54	63	9	9-1/2	19-1/16	21-1/16	49-3/8	48-13/16	20	20-7/16	65-1/2	5/8	3/8	9	11	107	136
815-35GO-60	816-35GO-60	60	69	9	9-1/2	21-1/16	23-5/16	54-11/16	54-1/8	21-3/16	21-9/16	71-1/2	5/8	3/8	9	11	131	145	
45°	815-45GO-18	816-45GO-18	18	27	8-1/2	9	7-1/16	9-1/6	16-1/2	15-3/4	13-5/8	14	29	1/2	1/4	6	8	45	52
	815-45GO-24	816-45GO-24	24	33	8-1/2	9	9-1/16	11-1/16	21-5/16	20-5/8	15-1/16	15-7/16	35	5/8	5/16	6	9-1/2	58	61
	815-45GO-30	816-45GO-30	30	39	8-1/2	9	11-1/16	13-1/6	26-1/8	25-7/16	16-1/2	16-7/8	41	5/8	5/16	6	9-1/2	65	71
	815-45GO-36	816-45GO-36	36	45	8-1/2	9	13-1/16	15-1/6	30-15/16	30-1/4	17-15/16	18-1/4	47	5/8	5/16	6	9-1/2	73	81
	815-45GO-42	816-45GO-42	42	51	9	9-1/2	15-1/16	17-1/16	35-13/16	35-1/16	19-3/4	20-1/8	53	5/8	5/16	7-1/2	9-1/2	90	96
	815-45GO-48	816-45GO-48	48	57	9	9-1/2	17-1/16	19-1/16	40-5/8	39-15/16	21-3/16	21-9/16	59	5/8	5/16	7-1/2	9-1/2	100	107
	815-45GO-54	816-45GO-54	54	63	9	9-1/2	19-1/16	21-1/16	45-7/16	44-3/4	22-5/8	23	65-1/2	5/8	3/8	9	11	125	138
815-45GO-60	816-45GO-60	60	69	9	9-1/2	21-1/16	23-5/16	50-1/4	49-9/16	24-1/16	24-3/8	71-1/2	5/8	3/8	9	11	133	147	

81 SERIES

* Recommended Bolt Pattern - See page 75 for minimum and maximum dimensions.

81 SERIES CEMA C REGREASEABLE IDLERS

LOW PROFILE CHANNEL MOUNT – 4" & 5" DIAMETER

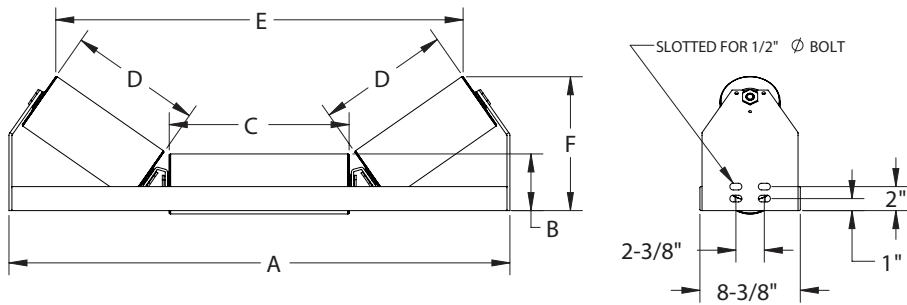

PART NUMBER		BW	A	B		C	D	E		F		WT (#)	
4"	5"			4"	5"			4"	5"	4"	5"	4"	5"
814-20CM-18	815-20CM-18	18	23 5/8	4-1/2	5	7-1/16	6-1/16	19-7/8	19-1/2	6-11/16	7-3/16	36	39
814-20CM-24	815-20CM-24	24	29-5/8	4-1/2	5	11-1/16	7-1/16	25-25/32	25-7/16	7-1/16	7-9/16	43	49
814-20CM-30	815-20CM-30	30	35-5/8	4-1/2	5	13-1/16	9-1/16	31-1/2	31-3/16	7-3/4	8-1/4	52	57
814-20CM-36	815-20CM-36	36	41-5/8	4-1/2	5	15-1/16	11-1/16	37-11/32	37	8-7/16	8-15/16	60	64
814-20CM-42	815-20CM-42	42	47-5/8	4-1/2	5	17-1/16	13-1/16	43-3/32	42-3/4	9-3/32	9-5/8	73	79
814-20CM-48	815-20CM-48	48	53-5/8	4-1/2	5	19-1/16	15-1/16	48-13/16	48-15/32	9-13/16	10-5/16	85	90
814-20CM-54	815-20CM-54	54	59-5/8	4-1/2	5	21-5/16	17-1/16	54-13/16	54-1/2	10-1/2	11	100	106
814-20CM-60	815-20CM-60	60	65-5/8	4-1/2	5	23-5/16	19-1/16	60-1/2	60-3/8	11-3/16	11-11/16	115	120
814-35CM-18	815-35CM-18	18	23 5/8	4-1/2	5	7-1/16	6-1/16	18-9/32	17-11/16	8-3/16	8-9/16	36	39
814-35CM-24	815-35CM-24	24	29-5/8	4-1/2	5	11-1/16	7-1/16	25-15/16	23-3/8	8-3/4	9-5/32	43	49
814-35CM-30	815-35CM-30	30	35-5/8	4-1/2	5	13-1/16	9-1/16	29-1/4	28-21/32	9-29/32	10-5/16	52	57
814-35CM-36	815-35CM-36	36	41-5/8	4-1/2	5	15-1/16	11-1/16	34-1/2	33-15/16	11-1/32	11-7/16	60	64
814-35CM-42	815-35CM-42	42	47-5/8	4-1/2	5	17-1/16	13-1/16	39-3/4	39-1/4	12-3/16	12-5/8	73	79
814-35CM-48	815-35CM-48	48	53-5/8	4-1/2	5	19-1/16	15-1/16	45-1/16	44-1/2	13-11/32	13-3/4	85	90
814-35CM-54	815-35CM-54	54	59-5/8	4-1/2	5	21-5/16	17-1/16	50-9/16	50	14-1/2	14-7/8	102	108
814-35CM-60	815-35CM-60	60	65-5/8	4-1/2	5	23-5/16	19-1/16	55-7/8	55-1/4	15-5/8	16-1/16	117	122

20°

35°

Note: Also available with the rubber cushion rollers (Designated by CMI).

81 SERIES CEMA C REGREASEABLE IDLERS

LOW PROFILE STANDARD MOUNT – 4" & 5" DIAMETER

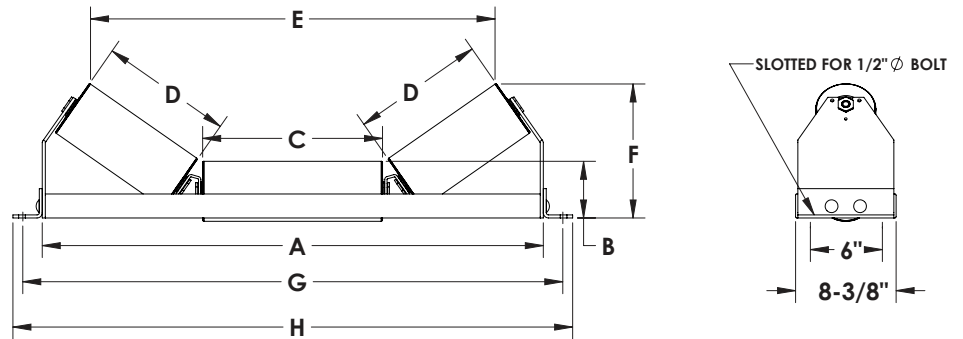

20°

35°

PART NUMBER		BW	A	B		C	D	G	H	E		F		WT (#)	
4"	5"			4"	5"					4"	5"	4"	5"	4"	5"
814-20SM-18	815-20SM-18	18	23-5/8	4-1/2	5	7-1/16	6-1/16	27	28-1/2	19-7/8	19-1/2	6-11/16	7-1/8	36	39
814-20SM-24	815-20SM-24	24	29-5/8	4-1/2	5	11-1/16	7-1/16	33	34-1/2	25-25/32	25-7/16	7	7-1/2	43	49
814-20SM-30	815-20SM-30	30	35-5/8	4-1/2	5	13-1/16	9-1/16	39	40-1/2	31-1/2	31-3/16	7-11/16	8-3/16	52	57
814-20SM-36	815-20SM-36	36	41-5/8	4-1/2	5	15-1/16	11-1/16	45	46-1/2	37-11/32	37	8-3/8	8-7/8	60	64
814-20SM-42	815-20SM-42	42	47-5/8	4-1/2	5	17-1/16	13-1/16	51	52-1/2	43-3/32	42-3/4	9-1/16	9-9/16	73	79
814-20SM-48	815-20SM-48	48	53-5/8	4-1/2	5	19-1/16	15-1/16	57	58-1/2	48-13/16	48-15/32	9-3/4	10-3/16	85	90
814-20SM-54	815-20SM-54	54	59-5/8	4-1/2	5	21-3/8	17-1/16	63	64-1/2	54-13/16	54-1/2	10-7/16	10-7/8	102	108
814-20SM-60	815-20SM-60	60	65-5/8	4-1/2	5	23-3/8	19-1/16	69	70-1/2	60-1/2	60-3/8	11-1/8	11-9/16	117	122
814-35SM-18	815-35SM-18	18	23-5/8	4-1/2	5	7-1/16	6-1/16	27	28-1/2	18-9/32	17-11/16	8-1/8	8-9/16	36	39
814-35SM-24	815-35SM-24	24	29-5/8	4-1/2	5	11-1/16	7-1/16	33	34-1/2	25-15/16	23-3/8	8-3/4	9-1/8	43	49
814-35SM-30	815-35SM-30	30	35-5/8	4-1/2	5	13-1/16	9-1/16	39	40-1/2	29-1/4	28-21/32	9-7/8	10-1/4	52	57
814-35SM-36	815-35SM-36	36	41-5/8	4-1/2	5	15-1/16	11-1/16	45	46-1/2	34-1/2	33-15/16	11	11-7/16	60	64
814-35SM-42	815-35SM-42	42	47-5/8	4-1/2	5	17-1/16	13-1/16	51	52 1/2	39-3/4	39-1/4	12-3/16	12-9/16	73	79
814-35SM-48	815-35SM-48	48	53-5/8	4-1/2	5	19-1/16	15-1/16	57	58-1/2	45-1/16	44-1/2	13-5/16	13-11/16	85	90
814-35SM-54	815-35SM-54	54	59-5/8	4-1/2	5	21-3/8	17-1/16	63	64-1/2	50-9/16	50	14-7/16	14-7/8	104	110
814-35SM-60	815-35SM-60	60	65-5/8	4-1/2	5	23-3/8	19-1/16	69	70-1/2	55-7/8	55-1/4	15-5/8	16	119	124

Note: Also available with the rubber cushion rollers (Designated by SMI).

91 SERIES CEMA D REGREASEABLE IDLERS

TROUGHING IDLERS (EQUAL LENGTH ROLLERS) – 5" & 6" DIAMETER

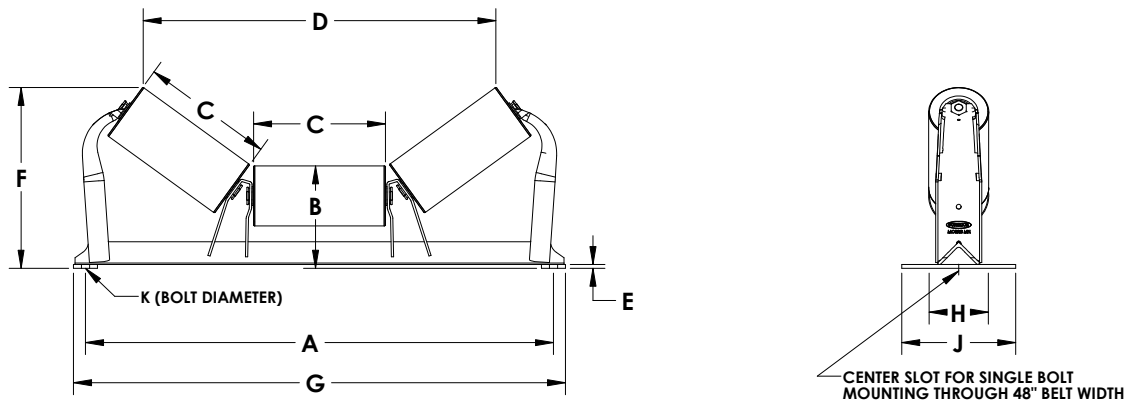

PART NUMBER		BW	A	B		C	D		E	F		G	H*	J	K	WT (#)	
5"	6"			5"	6"		5"	6"		5"	6"					5"	6"
915-20E-24	916-20E-24	24	33	8-1/2	9	9-1/16	27-5/8	26-15/16	5/16	11-11/16	12-1/8	35	6	9-1/2	5/8	45	51
915-20E-30	916-20E-30	30	39	8-1/2	9	11-1/16	33-1/16	32-3/4	5/16	12-3/8	12-7/8	41	6	9-1/2	5/8	56	61
915-20E-36	916-20E-36	36	45	9	9-1/2	13-1/16	38-13/16	38-1/2	5/16	13-1/16	14-1/32	47	6	9-1/2	5/8	65	69
915-20E-42	916-20E-42	42	51	9	9-1/2	15-1/16	44-9/16	44-1/4	5/16	14-3/16	14-3/4	53	7-1/2	9-1/2	5/8	81	88
915-20E-48	916-20E-48	48	57	9-3/8	9-7/8	17-1/16	50-3/8	50	5/16	14-7/8	15-3/4	59	7-1/2	9-1/2	5/8	91	100
915-20E-54	916-20E-54	54	63	9-7/16	9-15/16	19-1/16	56-1/8	55-3/4	3/8	15-5/8	16-1/2	65-1/2	9	11	5/8	100	118
915-20E-60	916-20E-60	60	69	9-7/16	9-15/16	21-1/16	61-7/8	61-1/2	3/8	16-5/16	17-3/16	71-1/2	9	11	5/8	108	124
915-20E-72	916-20E-72	72	81	9-7/16	9-15/16	25-1/16	73-3/8	73	3/8	18-1/8	18-9/16	83-1/2	9	11	5/8	127	143
915-35E-24	916-35E-24	24	33	8-1/2	9	9-1/16	24-11/16	24-1/8	5/16	13-13/16	14-3/16	35	6	9-1/2	5/8	49	53
915-35E-30	916-35E-30	30	39	8-1/2	9	11-1/16	30	29-7/16	5/16	14-15/16	15-3/8	41	6	9-1/2	5/8	59	64
915-35E-36	916-35E-36	36	45	9	9-1/2	13-1/16	35-1/4	34-11/16	5/16	16-1/8	17	47	6	9-1/2	5/8	67	71
915-35E-42	916-35E-42	42	51	9	9-1/2	15-1/16	40-9/16	40	5/16	17-11/16	18-3/16	53	7-1/2	9-1/2	5/8	85	90
915-35E-48	916-35E-48	48	57	9-3/8	9-7/8	17-1/16	45-13/16	45-1/4	5/16	18-7/8	19-11/16	59	7-1/2	9-1/2	5/8	94	102
915-35E-54	916-35E-54	54	63	9-7/16	9-15/16	19-1/16	51-1/8	50-1/2	3/8	20	20-7/8	65-1/2	9	11	5/8	104	123
915-35E-60	916-35E-60	60	69	9-7/16	9-15/16	21-1/16	56-5/16	55-13/16	3/8	21-3/16	22	71-1/2	9	11	5/8	111	128
915-35E-72	916-35E-72	72	81	9-7/16	9-15/16	25-1/16	66-7/8	66-5/16	3/8	23-15/16	24-5/16	83-1/2	9	11	5/8	123	147
915-45E-24	916-45E-24	24	33	8-1/2	9	9-1/16	22-3/4	22-1/6	5/16	15-1/16	15-7/16	35	6	9-1/2	5/8	51	55
915-45E-30	916-45E-30	30	39	8-1/2	9	11-1/16	27-5/8	26-7/8	5/16	16-1/2	16-7/8	41	6	9-1/2	5/8	60	66
915-45E-36	916-45E-36	36	45	9	9-1/2	13-1/16	32-7/16	31-3/4	5/16	17-15/16	18-3/4	47	6	9-1/2	5/8	67	73
915-45E-42	916-45E-42	42	51	9	9-1/2	15-1/16	37-1/4	36-9/16	5/16	19-3/4	20-3/16	53	7-1/2	9-1/2	5/8	89	95
915-45E-48	916-45E-48	48	57	9-3/8	9-7/8	17-1/16	42-1/16	41-3/8	5/16	21-3/16	21-15/16	59	7-1/2	9-1/2	5/8	96	104
915-45E-54	916-45E-54	54	63	9-7/16	9-15/16	19-1/16	46-15/16	46-3/16	3/8	22-5/8	23-7/16	65-1/2	9	11	5/8	107	127
915-45E-60	916-45E-60	60	69	9-7/16	9-15/16	21-1/16	51-3/4	51	3/8	24-1/16	24-7/8	71-1/2	9	11	5/8	116	131
915-45E-72	916-45E-72	72	81	9-7/16	9-15/16	25-1/16	61-3/8	60-11/16	3/8	27-5/16	27-11/16	83-1/2	9	11	5/8	133	150

20°

35°

45°

* Recommended Bolt Pattern - See page 75 for minimum and maximum dimensions.

91 SERIES CEMA D REGREASEABLE IDLERS

RETURN IDLERS – 4" & 5" DIAMETER

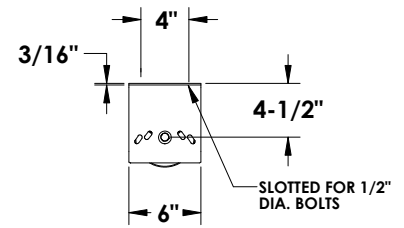
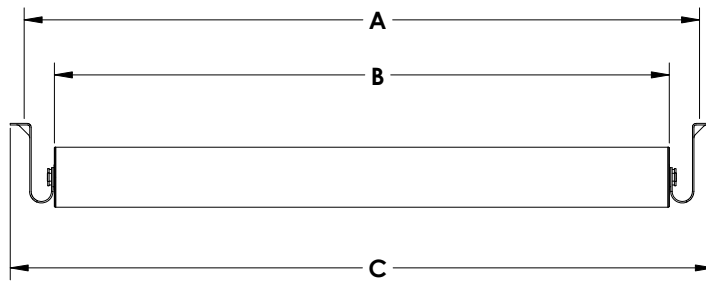

PART NUMBER		BW	A	B	C	WT (#)*	
5"	6"					5"	6"
915-RET-24	916-RET-24	24	33	27-5/16	34-3/4	31	36
915-RET-30	916-RET-30	30	39	33-5/16	40-3/4	36	40
915-RET-36	916-RET-36	36	45	39-5/16	46-3/4	40	47
915-RET-42	916-RET-42	42	51	45-5/16	52-3/4	42	50
915-RET-48	916-RET-48	48	57	51-5/16	58-3/4	50	57
915-RET-54	916-RET-54	54	63	57-5/16	64-3/4	55	61
915-RET-60	916-RET-60	60	69	63-5/16	70-3/4	60	65
915-RET-72	916-RET-72	72	81	75-5/16	82-3/4	64	70

FLAT IDLERS – 4" & 5" DIAMETER

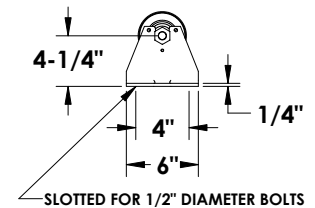
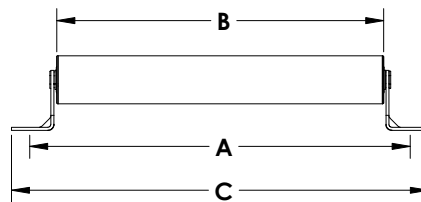

PART NUMBER		BW	A	B	C	WT (#)*	
5"	6"					5"	6"
915-FLT-24	916-FLT-24	24	33	27-5/16	34-3/4	32	36
915-FLT-30	916-FLT-30	30	39	33-5/16	40-3/4	36	40
915-FLT-36	916-FLT-36	36	45	39-5/16	46-3/4	40	47
915-FLT-42	916-FLT-42	42	51	45-5/16	52-3/4	43	50
915-FLT-48	916-FLT-48	48	57	51-5/16	58-3/4	50	57
915-FLT-54	916-FLT-54	54	63	57-5/16	64-3/4	55	61
915-FLT-60	916-FLT-60	60	69	63-5/16	70-3/4	60	65
915-FLT-72	916-FLT-72	72	81	75-5/16	82-3/4	64	70

* All weights include brackets, individual bracket weights are listed on page 74 and 75. Brackets not included.
Note: Return and Flat idlers are supplied with hold down kit for positive locking.

91 SERIES CEMA D REGREASEABLE IDLERS

RUBBER CUSHION IMPACT TROUGHING IDLER – 5" & 6" DIAMETER

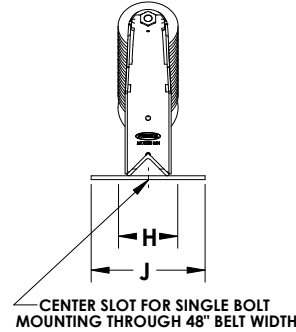
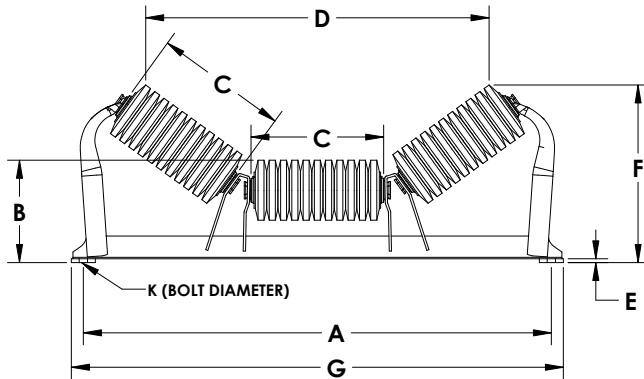

PART NUMBER		BW*	A	B		C	D		E	F		G	H**	J	K	WT (#)	
5"	6"			5"	6"		5"	6"		5"	6"					5"	6"
915-20EI-24	916-20EI-24	24	33	8-1/2	9	9-1/16	26-13/16	26-7/16	5/16	11-11/16	12-1/8	35	6	9-1/2	5/8	53	65
915-20EI-30	916-20EI-30	30	39	8-1/2	9	11-1/16	32-9/16	32-1/4	5/16	12-3/8	12-7/8	41	6	9-1/2	5/8	71	78
915-20EI-36	916-20EI-36	36	45	9	9-1/2	13-1/16	38-5/16	38	5/16	13-9/16	14 1/32	47	6	9-1/2	5/8	83	94
915-20EI-42	916-20EI-42	42	51	9	9-1/2	15-1/16	44-1/16	43-3/4	5/16	14-1/4	14-3/4	53	7-1/2	9-1/2	5/8	106	116
915-20EI-48	916-20EI-48	48	57	9-3/8	9-7/8	17-1/16	49-7/8	49-1/2	5/16	15-5/16	15-3/4	59	7-1/2	9-1/2	5/8	120	131
915-20EI-54	916-20EI-54	54	63	9-7/16	9-15/16	19-1/16	55-5/8	55-1/4	3/8	16-1/32	16-1/2	65-1/2	9	11	5/8	130	142
915-20EI-60	916-20EI-60	60	69	9-7/16	9-15/16	21-1/16	61-3/8	61	3/8	16-3/4	17-3/16	71-1/2	9	11	5/8	145	152
915-20EI-72	916-20EI-72	72	81	9-7/16	9-15/16	25-1/16	73	72-11/16	3/8	17-9/16	18-1/16	83-1/2	9	11	5/8	160	164
915-35EI-24	916-35EI-24	24	33	8-1/2	9	9-1/16	24-5/16	23-3/4	5/16	11-11/16	14-3/16	35	6	9-1/2	5/8	60	68
915-35EI-30	916-35EI-30	30	39	8-1/2	9	11-1/16	29-5/8	29-1/16	5/16	12-3/8	15-3/8	41	6	9-1/2	5/8	72	81
915-35EI-36	916-35EI-36	36	45	9	9-1/2	13-1/16	34-7/8	34-5/16	5/16	16-5/8	16	47	6	9-1/2	5/8	85	96
915-35EI-42	916-35EI-42	42	51	9	9-1/2	15-1/16	40-3/16	39-5/8	5/16	17-3/4	18-3/16	53	7-1/2	9-1/2	5/8	108	118
915-35EI-48	916-35EI-48	48	57	9-3/8	9-7/8	17-1/16	45-7/16	44-7/8	5/16	19-1/4	19-11/16	59	7-1/2	9-1/2	5/8	123	133
915-35EI-54	916-35EI-54	54	63	9-7/16	9-15/16	19-1/16	50-3/4	50-1/8	3/8	20-1/2	20-7/8	65-1/2	9	11	5/8	132	145
915-35EI-60	916-35EI-60	60	69	9-7/16	9-15/16	21-1/16	56	55-7/16	3/8	21-5/8	22	71-1/2	9	11	5/8	148	157
915-35EI-72	916-35EI-72	72	81	9-7/16	9-15/16	25-1/16	65-1/2	64-15/16	3/8	24-3/16	24-11/16	83-1/2	9	11	5/8	164	172
915-45EI-24	916-45EI-24	24	33	8-1/2	9	9-1/16	22-3/4	21-11/16	5/16	15-1/16	15-7/16	35	6	9-1/2	5/8	51	70
915-45EI-30	916-45EI-30	30	39	8-1/2	9	11-1/16	27-5/8	26-1/2	5/16	16-1/8	16-7/8	41	6	9-1/2	5/8	60	81
915-45EI-36	916-45EI-36	36	45	9	9-1/2	13-1/16	32-7/16	32-1/16	5/16	18-7/16	18-3/4	47	6	9-1/2	5/8	67	98
915-45EI-42	916-45EI-42	42	51	9	9-1/2	15-1/16	37-1/4	36-3/16	5/16	19-13/16	20-3/16	53	7-1/2	9-1/2	5/8	89	120
915-45EI-48	916-45EI-48	48	57	9-3/8	9-7/8	17-1/16	42-1/16	41	5/16	21-5/8	21-15/16	59	7-1/2	9-1/2	5/8	96	136
915-45EI-54	916-45EI-54	54	63	9-7/16	9-15/16	19-1/16	46-15/16	45-13/16	3/8	23-1/16	23-7/16	65-1/2	9	11	5/8	107	148
915-45EI-60	916-45EI-60	60	69	9-7/16	9-15/16	21-1/16	51-3/4	50-9/16	3/8	24-1/2	24-7/8	71-1/2	9	11	5/8	116	159
915-45EI-72	916-45EI-72	72	81	9-7/16	9-15/16	25-1/16	61-3/8	60-7/16	3/8	27-5/16	26-15/16	83-1/2	9	11	5/8	133	174

20°

35°

45°

* Belt Width (Reinforcing on 36" BW - 72" BW Impact Frame only).

** Recommended Bolt Pattern - See page 75 for minimum and maximum dimensions.

91 SERIES CEMA D REGREASEABLE IDLERS

RUBBER CUSHION RETURN IDLERS – 5" & 6" DIAMETER

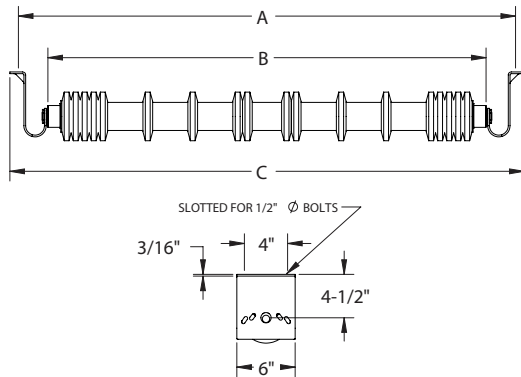

PART NUMBER		BW	A	B	C	WT (#)*	
5"	6"					5"	6"
915-RETI-24	916-RETI-24	24	33	27-5/16	34-3/4	30	36
915-RETI-30	916-RETI-30	30	39	33-5/16	40-3/4	36	40
915-RETI-36	916-RETI-36	36	45	39-5/16	46-3/4	40	47
915-RETI-42	916-RETI-42	42	51	45-5/16	52-3/4	43	50
915-RETI-48	916-RETI-48	48	57	51-5/16	58-3/4	50	57
915-RETI-54	916-RETI-54	54	63	57-5/16	64-3/4	55	61
915-RETI-60	916-RETI-60	60	69	63-5/16	70-3/4	60	65
915-RETI-72	916-RETI-72	72	81	75-5/16	82-3/4	76	70

RUBBER CUSHION FLAT IDLERS – 5" & 6" DIAMETER

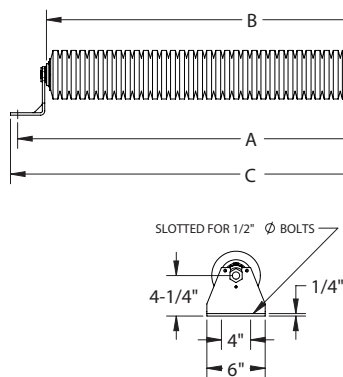

PART NUMBER		BW	A	B	C	WT (#)*	
5"	6"					5"	6"
915-FLTI-24	916-FLTI-24	24	33	27-5/16	34-3/4	47	50
915-FLTI-30	916-FLTI-30	30	39	33-5/16	40-3/4	53	57
915-FLTI-36	916-FLTI-36	36	45	39-5/16	46-3/4	60	66
915-FLTI-42	916-FLTI-42	42	51	45-5/16	52-3/4	68	75
915-FLTI-48	916-FLTI-48	48	57	51-5/16	58-3/4	76	83
915-FLTI-54	916-FLTI-54	54	63	57-5/16	64-3/4	82	91
915-FLTI-60	916-FLTI-60	60	69	63-5/16	70-3/4	89	101
915-FLTI-72	916-FLTI-72	72	81	75-5/16	82-3/4	96	112

SELF-ALIGNING RETURN IDLERS – 5" & 6" DIAMETER

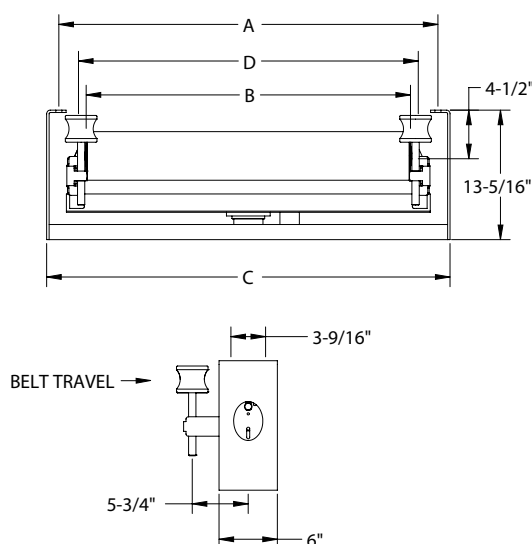

PART NUMBER**		BW	A	B	C	D	WT (#)
5"	6"						
915-RETA-24	916-RETA-24	24	33	27-5/16	35-3/4	29-5/8	88
915-RETA-30	916-RETA-30	30	39	33-5/16	41-3/4	35-5/8	116
915-RETA-36	916-RETA-36	36	45	39-5/16	47-3/4	41-5/8	122
915-RETA-42	916-RETA-42	42	51	45-5/16	53-3/4	47-5/7	154
915-RETA-48	916-RETA-48	48	57	51-5/16	59-3/4	53-5/8	164
915-RETA-54	916-RETA-54	54	63	57-5/16	65-3/4	59-5/8	177
915-RETA-60	916-RETA-60	60	69	63-5/16	71-3/4	65-5/8	193
915-RETA-72	916-RETA-72	72	81	75-5/16	83-3/4	77-5/8	222

* All weights include brackets

** Also available in bi-directional. Designated by (RETBA). Individual bracket weights are listed on page 74 and 75. Brackets not included.

91 SERIES CEMA D REGREASEABLE IDLERS

SELF-ALIGNING TROUGHING IDLERS – 5" & 6" DIAMETER

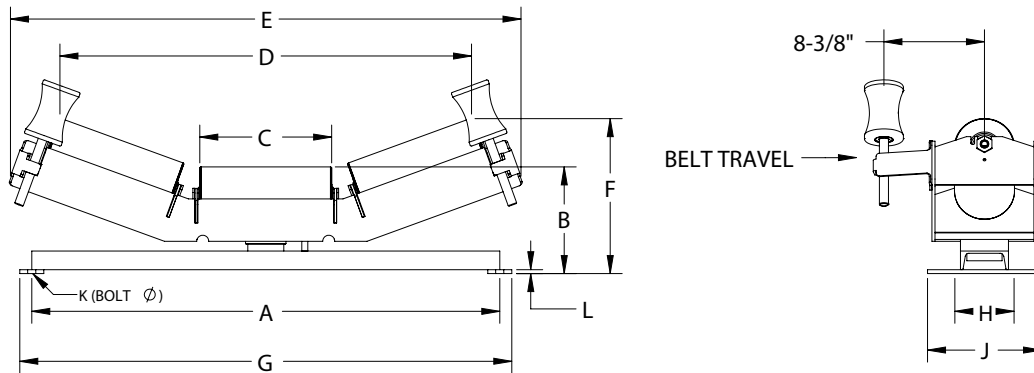

PART NUMBER		BW	A	B		C	D		E	F		G	H	J	K	WT (#)	
5"	6"			5"	6"		5"	6"		5"	6"					5"	6"
915-20EA-24	916-20EA-24	24	33	9-9/16	10-1/16	9-1/16	27-5/16	26-15/16	36-3/4	12-3/4	13-3/16	35	6	11	1/2	96	100
915-20EA-30	916-20EA-30	30	39	9-5/8	10-1/8	11-1/16	33-1/16	32-3/4	42-1/2	13-7/16	14	41	6	11	1/2	105	110
915-20EA-36	916-20EA-36	36	45	9-5/8	10-1/8	13-1/16	38-13/16	38-1/2	48-1/8	14-1/8	14-5/8	47	6	11	1/2	116	120
915-20EA-42	916-20EA-42	42	51	9-15/16	10-7/16	15-1/16	44-9/16	44-1/4	54-3/8	15-1/4	15-3/4	53	7-1/2	11	5/8	139	145
915-20EA-48	916-20EA-48	48	57	9-15/16	10-7/16	17-1/16	50-3/8	50	60-5/8	16	16-7/16	59	7-1/2	11	5/8	149	156
915-20EA-54	916-20EA-54	54	63	9-15/16	10-7/16	19-1/16	56-1/8	55-3/4	65	16-7/16	17-3/16	65-1/2	9	11	5/8	165	168
915-20EA-60	916-20EA-60	60	69	9-15/16	10-7/16	21-1/16	61-7/8	61-1/2	70-1/2	17-1/4	17-13/16	71-1/2	9	11	5/8	175	182
915-20EA-72	916-20EA-72	72	81	9-15/16	10-7/16	25-1/16	73-3/4	67-1/4	82-7/8	18-1/16	18-1/2	83-1/2	9	11	5/8	187	196
915-35EA-24	916-35EA-24	24	33	9-9/16	10-1/16	9-1/16	24-11/16	24-1/8	37-1/2	14-7/8	15-1/4	35	6	11	1/2	98	100
915-35EA-30	916-35EA-30	30	39	9-5/8	10-1/8	11-1/16	30	29-7/16	42-1/2	15-7/8	16-7/16	41	6	11	1/2	107	112
915-35EA-36	916-35EA-36	36	45	9-5/8	10-1/8	13-1/16	35-1/4	34-11/16	47-5/8	17-3/16	17-9/16	47	6	11	1/2	118	122
915-35EA-42	916-35EA-42	42	51	9-15/16	10-7/16	15-1/16	40-9/16	40	54-1/8	18-3/4	19-3/16	53	7-1/2	11	5/8	141	145
915-35EA-48	916-35EA-48	48	57	9-15/16	10-7/16	17-1/16	45-13/16	45-1/4	59-3/4	20	20-5/16	59	7-1/2	11	5/8	151	157
915-35EA-54	916-35EA-54	54	63	9-15/16	10-7/16	19-1/16	51-1/8	50-1/2	64	21-1/16	21-1/2	65-1/2	9	11	5/8	165	171
915-35EA-60	916-35EA-60	60	69	9-15/16	10-7/16	21-1/16	56-5/16	55-13/16	69	22-1/4	22-5/8	71-1/2	9	11	5/8	177	183
915-35EA-72	916-35EA-72	72	81	9-15/16	10-7/16	25-1/16	66-7/8	61-1/8	81-3/16	22-7/16	24-3/8	83-1/2	9	11	5/8	189	195
915-45EA-24	916-45EA-24	24	33	9-9/16	10-1/16	9-1/16	22-3/4	22-1/16	36-1/8	16-1/8	16-1/2	35	6	11	1/2	99	101
915-45EA-30	916-45EA-30	30	39	9-5/8	10-1/8	11-1/16	27-5/8	26-7/8	41-5/8	17-5/8	18	41	6	11	1/2	108	116
915-45EA-36	916-45EA-36	36	45	9-5/8	10-1/8	13-1/16	32-7/16	31-3/4	46-3/8	19-1/16	19-3/8	47	6	11	1/2	119	123
915-45EA-42	916-45EA-42	42	51	9-15/16	10-7/16	15-1/16	37-1/4	36-9/16	53-1/8	20-3/4	21-1/8	53	7-1/2	11	5/8	142	147
915-45EA-48	916-45EA-48	48	57	9-15/16	10-7/16	17-1/16	42-1/16	41-3/8	58-1/4	22-3/16	21-7/8	59	7-1/2	11	5/8	153	159
915-45EA-54	916-45EA-54	54	63	9-15/16	10-7/16	19-1/16	46-15/16	46-3/16	62-1/2	23-5/8	24	65-1/2	9	11	5/8	170	172
915-45EA-60	916-45EA-60	60	69	9-15/16	10-7/16	21-1/16	51-3/4	51	66-3/4	25	25-3/8	71-1/2	9	11	5/8	179	184
915-45EA-72	916-45EA-72	72	81	9-15/16	10-7/16	25-1/16	61-3/8	72-7/8	79-3/16	26-5/8	26-7/8	83-1/2	9	11	5/8	191	196

20°

35°

45°

Note: Also available in bi-directional shoe-activated option. Designated by (BA).

91 SERIES CEMA D REGREASEABLE IDLERS

FEEDER / PICKING TROUGHING IDLERS – 5" & 6" DIAMETER

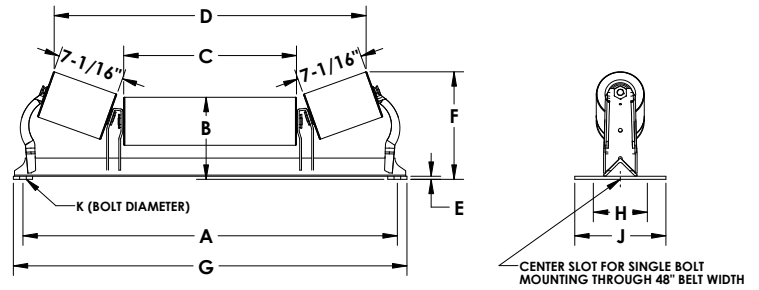

PART NUMBER**		BW*	A	B		C	D		E	F		G	H***	J		K	WT (#)	
5"	6"			5"	6"		5"	6"		5"	6"			5"	6"		5"	6"
915-20P-24	916-20P-24	24	33	8-1/2	9	12-1/16	26-7/16	26-3/32	5/16	11	11-1/2	35	6	9-1/2	11	5/8	48	54
915-20P-30	916-20P-30	30	39	8-1/2	9	18-1/16	32-9/16	32-3/16	5/16	11	11-1/2	41	6	9-1/2	11	5/8	55	61
915-20P-36	916-20P-36	36	45	9	9-1/2	24-1/16	38-9/16	38-3/16	5/16	11	11-1/2	47	6	9-1/2	11	5/8	59	71
915-20P-42	916-20P-42	42	51	9	9-1/2	30-1/16	44-9/16	44-3/16	5/16	11-1/2	11-15/16	53	7-1/2	9-1/2	11	5/8	78	89
915-20P-48	916-20P-48	48	57	9-3/8	9-7/8	36-1/16	50-9/16	50-3/16	5/16	11-1/2	11-15/16	59	7-1/2	9-1/2	11	5/8	86	94
915-20P-54	916-20P-54	54	63	9-7/16	9-15/16	42-1/16	56-9/16	56-3/16	3/8	11-1/2	11-15/16	65-1/2	9	11	11	5/8	99	110
915-20P-60	916-20P-60	60	69	9-7/16	9-15/16	48-1/16	62-9/16	62-3/16	3/8	11-1/2	11-15/16	71-1/2	9	11	11	5/8	106	120
915-20P-72	916-20P-72	72	81	9-7/16	9-15/16	60-1/16	74-9/16	74-7/16	3/8	11-1/2	11-15/16	83-1/2	9	11	11	5/8	128	154

TROUGHING IDLERS (UNEQUAL LENGTH ROLLERS) 5" & 6" DIAMETER

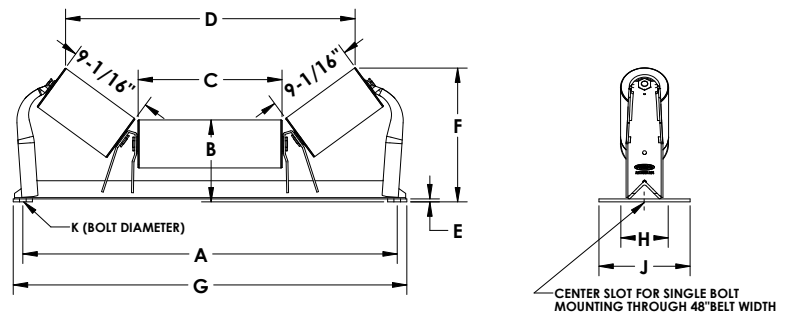

	PART NUMBER**		BW*	A	B		C	D		E	F		G	H	J	K	WT (#)	
	5"	6"			5"	6"		5"	6"		5"	6"					5"	6"
35°	915-35U-30	916-35U-30	30	39	8-1/2	9	15-1/16	30-3/4	30-1/8	5/16	13-3/16	13-3/16	41	6	9-1/2	5/8	57	64
	915-35U-36	916-35U-36	36	45	9	9-1/2	21-5/16	37-1/16	36-1/2	5/16	13-3/16	13-3/16	47	6	9-1/2	5/8	65	75
	915-35U-42	916-35U-42	42	51	9	9-1/2	27-5/16	43-1/16	42-1/2	5/16	14-1/4	14-1/4	53	7-1/2	9-1/2	5/8	81	90
	915-35U-48	916-35U-48	48	57	9-3/8	9-7/8	33-5/16	49-1/16	48-1/2	5/16	14-1/4	14-1/4	59	7-1/2	9-1/2	5/8	92	100
	915-35U-54	916-35U-54	54	63	9-7/16	9-15/16	39-5/16	55-1/16	54-1/2	3/8	14-5/16	14-5/16	65-1/2	9	11	5/8	97	106
	915-35U-60	916-35U-60	60	69	9-7/16	9-15/16	45-5/16	61-1/16	60-1/2	3/8	14-5/16	14-5/16	71-1/2	9	11	5/8	106	111
45°	915-45U-30	916-45U-30	30	39	8-1/2	9	15-1/16	28-3/4	28-1/16	5/16	15-1/16	15-7/16	41	6	9-1/2	5/8	60	66
	915-45U-36	916-45U-36	36	45	9	9-1/2	21-5/16	35-1/8	34-3/8	5/16	15-1/16	15-7/16	47	6	9-1/2	5/8	68	78
	915-45U-42	916-45U-42	42	51	9	9-1/2	27-5/16	41-1/8	40-3/8	5/16	15-9/16	15-7/8	53	7-1/2	9-1/2	5/8	85	96
	915-45U-48	916-45U-48	48	57	9-3/8	9-7/8	33-5/16	47-1/8	46-3/8	5/16	15-9/16	15-7/8	59	7-1/2	9-1/2	5/8	95	102
	915-45U-54	916-45U-54	54	63	9-7/16	9-15/16	39-5/16	53-1/8	52-3/8	3/8	15-9/16	15-15/16	65-1/2	9	11	5/8	99	108
	915-45U-60	916-45U-60	60	69	9-7/16	9-15/16	45-5/16	59-1/8	58-3/8	3/8	15-9/16	15-15/16	71-1/2	9	11	5/8	109	113

* Belt Width (Reinforcing on 36" BW - 72" BW frame only).

** Also available in rubber cushion rollers. Designated by (PI=picking impact) (UI=unequal impact).

*** Recommended Bolt Pattern - See page 75 for minimum and maximum dimensions.

REGREASEABLE IDLERS PARTS

ROLLER & IDLER COMPONENTS PARTS 4", 5", & 6" DIAMETER

81 SERIES REPLACEMENT ROLLS							
BW	ROLL LENGTH*	4" DIA. ROLL PART NUMBER	WT (#)	5" DIA. ROLL PART NUMBER	WT (#)	6" DIA. ROLL PART NUMBER	WT (#)
18	7-1/16	814-18	6	815-18	8	816-18	9
24	9-1/16	814-24	7	815-24	9	816-24	11
30	11-1/16	814-30	8	815-30	11	816-30	12
36	13-1/16	814-36	9	815-36	12	816-36	13
42	15-1/16	814-42	10	815-42	13	816-42	15
48	17-1/16	814-48	11	815-48	15	816-48	17
54	19-1/16	814-54	12	815-54	16	816-54	19
60	21-1/16	814-60	13	815-60	18	816-60	21
18	7-1/16	814-EI-18	8	815-EI-18	10	816-EI-18	12
24	9-1/16	814-EI-24	10	815-EI-24	12	816-EI-24	15
30	11-1/16	814-EI-30	12	815-EI-30	14	816-EI-30	17
36	13-1/16	814-EI-36	14	815-EI-36	16	816-EI-36	19
42	15-1/16	814-EI-42	17	815-EI-42	19	816-EI-42	22
48	17-1/16	814-EI-48	19	815-EI-48	21	816-EI-48	26
54	19-1/16	814-EI-54	21	815-EI-54	24	816-EI-54	27
60	21-1/16	814-EI-60	24	815-EI-60	26	816-EI-60	28

Equal Length Idler Rolls

Rubber Impact Idler Rolls

81 & 91 SERIES ROLL AND IDLER PARTS	
PART NUMBER	DESCRIPTION
38-460083	Grease Tube
13-10041	Grease Zerk 1/8"
13-10043	Grease Zerk 1/4"
13-10044	Grease Relief Fitting 1/8"
08-10007	Hex Bushing 1/4"
13-10201	Center Clip 20°
13-10351	Center Clip 35°
13-10451	Center Clip 45°
13-10011	Screw-Rolock 1/4" x 3/8"
13-10039	Retainer Clip (Flat)
13-10040	Retainer Clip (Curved)
13-10052	Kit-Holder Down Clip (Ret & Fit)
09-104200	Rubber Disc 4" Dia. x 2" I.D.
09-105200	Rubber Disc 5" Dia. x 2" I.D.
09-104225	Rubber Disc 4" Dia. x 2 1/4" I.D.
09-105225	Rubber Disc 5" Dia. x 2 1/4" I.D.
09-106225	Rubber Disc 6" Dia. x 2 1/4" I.D.
03-01015	Kit-Bearing & Seal 81/91 Series

*Assembled Roll Approximate Length

91 SERIES REPLACEMENT ROLLS					
BW	ROLL LENGTH*	5" DIA. ROLL PART NUMBER	WT (#)	6" DIA. ROLL PART NUMBER	WT (#)
18	7-1/16	915-18	8	916-18	9
24	9-1/16	915-24	9	916-24	11
30	11-1/16	915-30	11	916-30	12
36	13-1/16	915-36	12	916-36	13
42	15-1/16	915-42	13	916-42	15
48	17-1/16	915-48	15	916-48	17
54	19-1/16	915-54	16	916-54	19
60	21-1/16	915-60	18	916-60	21
72	25-1/16	915-72	23	916-72	27
18	7-1/16	915-EI-18	10	916-EI-18	12
24	9-1/16	915-EI-24	12	916-EI-24	15
30	11-1/16	915-EI-30	14	916-EI-30	17
36	13-1/16	915-EI-36	16	916-EI-36	19
42	15-1/16	915-EI-42	19	916-EI-42	22
48	17-1/16	915-EI-48	21	916-EI-48	26
54	19-1/16	915-EI-54	24	916-EI-54	27
60	21-1/16	915-EI-60	26	916-EI-60	28
72	25-1/16	915-EI-72	31	916-EI-72	34

Equal Length Idler Rolls

Rubber Impact Idler Rolls

*Assembled Roll Approximate Length

40 SERIES IDLERS

40 SERIES IDLER

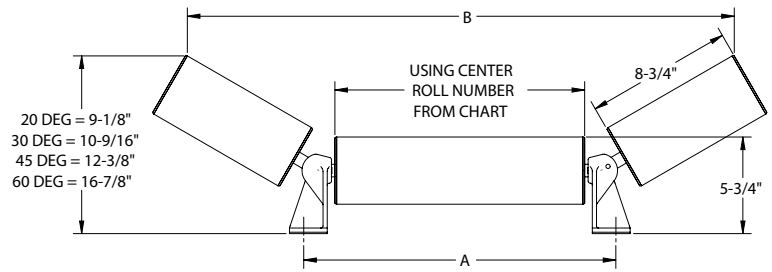

CENTER ROLL PART NUMBERS	POWERSCREEN #	RECOMMENDED BW	A	B				CENTER ROLL LENGTH	SHAFT LENGTH
				20°	30°	45°	60°T		
43-000010	07020238	24	11-7/8	27-15/16	25-13/16	21-3/4	13-9/16	8.14	9.20
43-000011	02021138	30	15-3/4	31-13/16	29-11/16	25-5/8	17-7/16	12.00	13.06
43-000012	08010101	30	18-5/8	34-11/16	32-9/16	28-1/2	20-5/16	14.87	15.93
43-000013	06530102	36	22-5/8	38-11/16	36-9/16	32-1/2	24-5/16	18.87	19.93
43-000014	05120115	36	24-9/16	40-5/8	38-1/2	34-7/16	26-1/4	20.87	21.87
43-000015	04220133	42	28-7/8	44-15/16	42-13/16	38-3/4	30-9/16	25.15	26.21
43-000016	09130180	42	30-1/2	46-9/16	44-7/16	40-3/8	32-3/16	26.75	27.81
43-000017	09120129	48	38-13/16	54-7/8	52-3/4	48-11/16	40-1/2	35.07	36.13
43-000018	03220103	54	39-9/16	55-5/8	53-1/2	49-7/16	41-1/4	33.87	36.87

CENTER BRACKETS

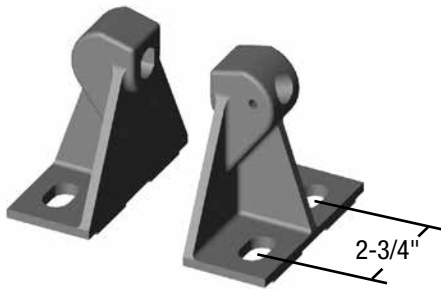

PART NUMBERS	POWERSCREEN #	DESCRIPTION	DEGREE
43-000021	LH2020608 RH2020609	Center bracket only	20
43-000022	LH2020606 RH2020607	Center bracket only	30
43-000023	LH2020604 RH2020605	Center bracket only	45
43-000024	LH2020610 RH2020611	Center bracket only	60

OUTSIDE ROLLS

PART NUMBER	POWERSCREEN #	DESCRIPTION	DEGREE	ROLL LENGTH
43-000019	8 - 3/4	Outside roller only	Fits all degrees	8-3/4"

RETURN ROLL U-BOLTS

PART NUMBERS	SHAFT DIAMETER
13-03004	1"
13-03005	.75"

RETURN ROLLS

PART NUMBERS	POWERSCREEN #	ROLL LENGTH	SHAFT LENGTH	METRIC SIZE	RECOMMENDED BELT WIDTH
43-000025	02021145	28.00"	33.00"	L840	24
43-000026	06530103	33.50"	38.50"	L978	30
43-000027	05420143	33.62"	38.62"	L980	30
43-000028	08010102	35.50"	40.50"	L1025	30
43-000029	05120116	40.00"	45.00"	L1145	36
43-000030	03220104	53.50"	58.50"	L1485	48
43-000031	07230107	62.00"	67.00"	L1700	60

CB 504 SERIES IDLERS

TROUGHING IDLER – 4-1/2" DIAMETER

4-1/2" PART NUMBER	BW	A	B	C	D	E	F	G	H	J	K	WT (#)
CB45-20E-18	18	27	7 1/2	6-1/2	20-3/8	1/4	9-7/16	29	6	8	5/8	22
CB45-20E-24	24	33	7-1/2	8-1/2	26-1/8	1/4	10-1/8	35	6	8	5/8	25
CB45-20E-30	30	39	7-1/2	10-1/2	31-7/8	1/4	10-13/16	41	6	8	5/8	30
CB45-20E-36	36	45	7-1/2	12-1/2	37-5/8	1/4	11-1/2	47	6	8	5/8	32
CB45-20E-42	42	51	7-1/2	14-1/2	43-1/4	5/16	12-9/16	53	7-1/2	8	5/8	35
CB45-20E-48	48	57	7-1/2	16-1/2	49	5/16	13-1/4	59	7-1/2	8	5/8	38
CB45-35E-18	18	27	7-1/2	6 1/2	17-23/64	1/4	11-9/32	29	6	8	1/2	41
CB45-35E-24	24	33	7-1/2	8-1/2	22-5/8	1/4	12-13/32	35	6	8	1/2	48
CB45-35E-30	30	39	7-1/2	10-1/2	27-29/32	1/4	13-9/16	41	6	8	1/2	57
CB45-35E-36	36	45	7-1/2	12 1/2	33-3/16	1/4	14-23/32	47	6	8	1/2	65
CB45-35E-42	42	51	7-1/2	14-1/2	38-15/32	5/16	15-27/32	53	6	8	1/2	78
CB45-35E-48	48	57	7-1/2	16-1/2	43-3/4	5/16	17	59	6	8	1/2	90

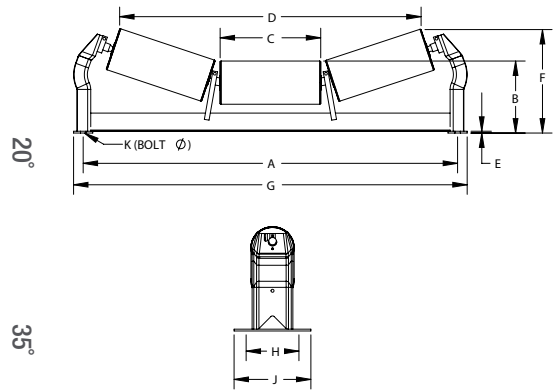

** Also available in rubber cushioned roller. Designated by (EI).
 Note: Also available in 4" diameter; dimensions are subject to change without notice.

LOW PROFILE CHANNEL MOUNT – 4-1/2" DIAMETER

4-1/2" PART NUMBER	BW	A	B	C	D	E	WT (#)
CB45-20CM-18	18	23-3/4	4-7/8	6-1/2	20-1/8	7-1/4	36
CB45-20CM-24	24	29-3/4	4-7/8	8-1/2	25-15/16	7-15/16	43
CB45-20CM-30	30	35-3/4	4-7/8	10-1/2	31-21/32	8-5/8	52
CB45-20CM-36	36	41-3/4	4-7/8	12-1/2	37-13/32	9-5/16	60
CB45-20CM-42	42	47-3/4	4-7/8	14-1/2	43-3/16	10	73
CB45-20CM-48	48	53-3/4	4-7/8	16-1/2	48-15/16	10-11/16	85
CB45-35CM-18	18	23-3/4	4-7/8	6-1/2	17-3/8	7-25/32	37
CB45-35CM-24	24	29-3/4	4-7/8	8-1/2	22-5/8	8-5/8	44
CB45-35CM-30	30	35-3/4	4-7/8	10-1/2	27-15/16	10-15/16	53
CB45-35CM-36	36	41-3/4	4-7/8	12-1/2	33-3/16	12-1/8	61
CB45-35CM-42	42	47-3/4	4-7/8	14-1/2	38-15/32	13-1/4	74
CB45-35CM-48	48	53-3/4	4-7/8	16-1/2	43-3/4	14-3/8	86

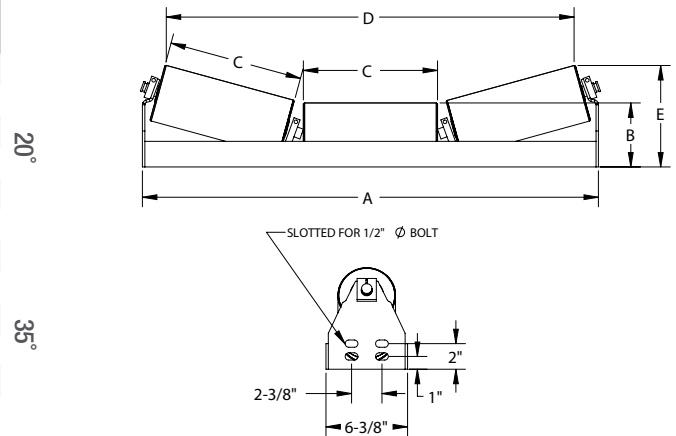

** Also available in rubber cushioned roller.
 Designated by (CMI). Note: Dimensions are subject to change without notice. Certified prints available for construction.

BEARING STUB SHAFT REPLACEMENT ROLLERS 4" & 4-1/2" DIAMETER ORDERING GUIDE

CB45 - 10.50

1. Roll Diameter

2. Roll Length

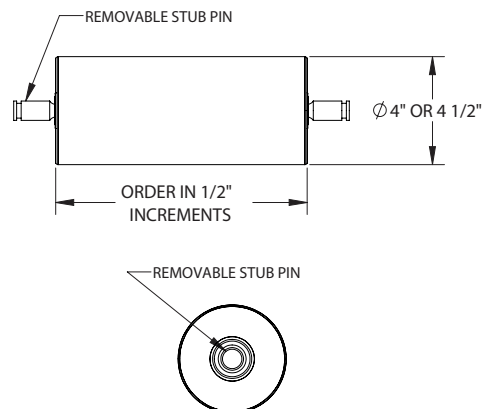

CB 504 PARTS			
PART NUMBER	DESCRIPTION	PART NUMBER	DESCRIPTION
41-541250	2 1/2" Single Pin	30-456024	4-1/2" End Disc
41-542250	2 1/2" Double Pin	03-01017	CB 504 Bearing
41-542263	2 5/8" Double Pin	32-044081	1 1/2" Drop Bracket
41-541300	3" Single Pin	32-410450	4-1/2" Drop Bracket
41-542300	3" Double Pin	32-506000	Channel Mount Bracket
30-405044	4" End Disc		

** Also available in rubber cushioned roller. Designated by (CBI).
 Note: Also available in 4" diameter

COMPONENTS ACCESSORIES

NAVIGATOR RETURN TRAINER- 7-3/4" & 7", 10" & 10-3/4" DIAMETER

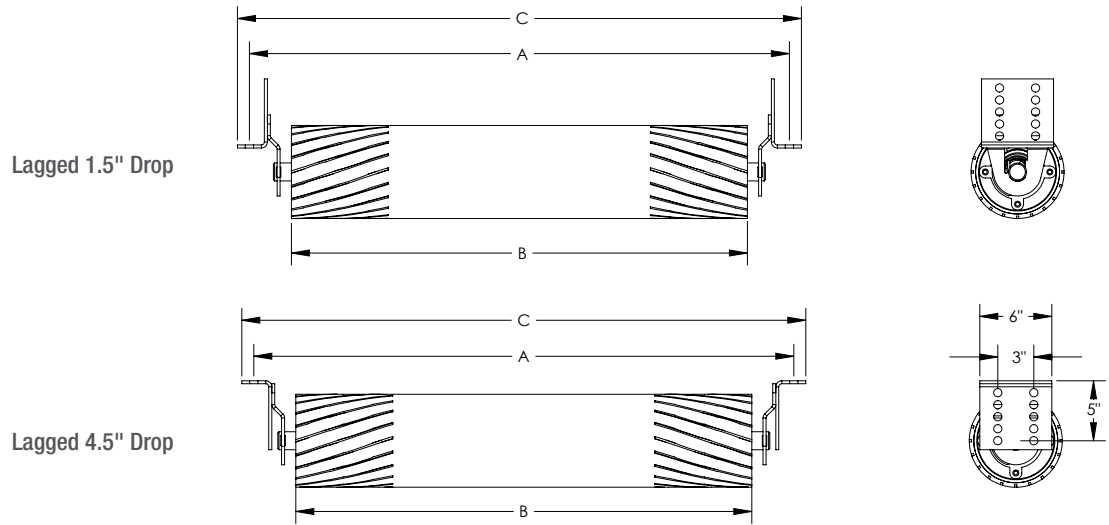

PART NUMBER		BW*	A	B	C	DIAMETER		WT (#)**		STANDARD DROP BRACKET	BIDIRECTIONAL DROP BRACKET
LAGGED	NOT LAGGED					LAGGED	NOT LAGGED	LAGGED	NOT LAGGED		
NAV-24LAG	NAV-24	24	33	26	35	7-3/4	7	87	76	32-010009	32-010050
NAV-30LAG	NAV-30	30	39	32	41	7-3/4	7	101	88	32-010009	32-010050
NAV-36LAG	NAV-36	36	45	38	47	7-3/4	7	116	100	32-010009	32-010050
NAV-42LAG	NAV-42	42	51	44	53	10-3/4	10	180	153	32-010019	32-010052
NAV-48LAG	NAV-48	48	57	50	59	10-3/4	10	201	171	32-010019	32-010052
NAV-54LAG	NAV-54	54	63	56	65	10-3/4	10	244	210	32-010020	32-010054
NAV-60LAG	NAV-60	60	69	62	71	10-3/4	10	267	230	32-010020	32-010054
NAV-66LAG	NAV-66	66	75	68	77	10-3/4	10	291	250	32-010020	32-010054
NAV-72LAG	NAV-72	72	81	74	83	10-3/4	10	314	269	32-010020	32-010054

RETURN GUIDES

Part Number: 42-000001

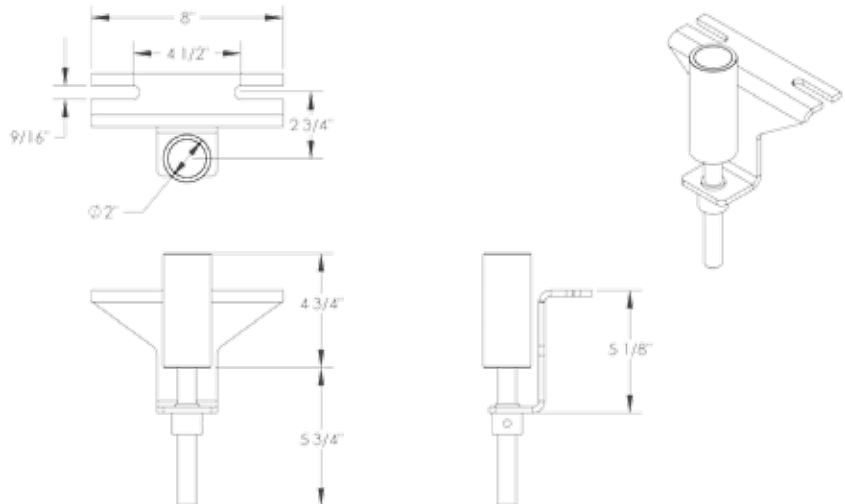

COMPONENT ACCESSORIES

80/81 & 90/91 HEX STYLE ROLL GUARD

PART NUMBER	BW	GUARD LENGTH
44-010018	18	21-1/8
44-010024	24	27-1/8
44-010030	30	33-1/8
44-010036	36	39-1/8
44-010042	42	45-1/8
44-010048	48	51-1/8
44-010054	54	57-1/8
44-010060	60	63-1/8
44-010072	72	75-1/8

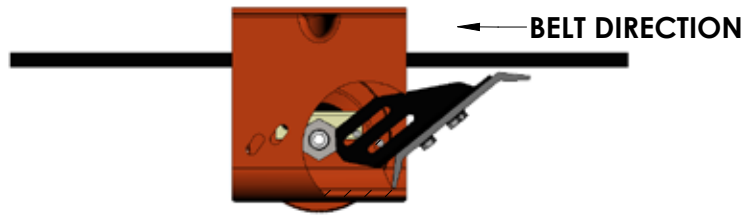

SLOTTED SHAFT RETURN GUARD – CEMA B, C, & D IDLERS

NOTE: Universal for rise, drop, and channel mount brackets.

PART NUMBER	BW	GUARD LENGTH
44-050118	18	21-1/8
44-050124	24	27-1/8
44-050130	30	33-1/8
44-050136	36	39-1/8
44-050142	42	45-1/8
44-050148	48	51-1/8
44-050154	54	57-1/8
44-050160	60	63-1/8
44-050172	72	75-1/8

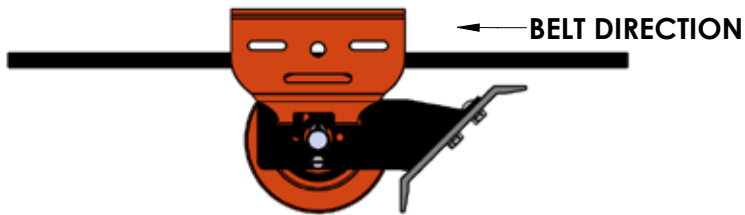

BEATER BAR RETURN ROLL – 1 7/16" & 1 15/16" SHAFT SIZE

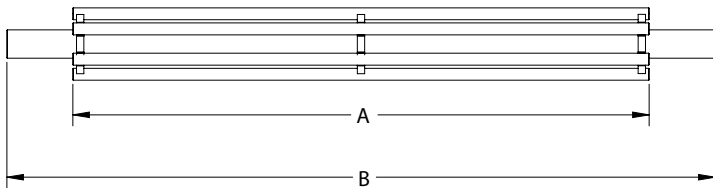

ROLL DIAMETER		BW	A	B	WT		ROLL DIAMETER		BW	A	B	WT (#)	
5"	6"				5"	6"	5"	6"				5"	6"
LSB-518-107	LSB-618-107	18	21-5/16	30-5/16	36	38	LSB-518-115	LSB-618-115	18	21-5/16	30-5/16	47	49
LSB-524-107	LSB-624-107	24	27-5/16	36-5/16	44	46	LSB-524-115	LSB-624-115	24	27-5/16	36-5/16	57	59
LSB-530-107	LSB-630-107	30	33-5/16	42-5/16	53	56	LSB-530-115	LSB-630-115	30	33-5/16	42-5/16	69	71
LSB-536-107	LSB-636-107	36	39-1/16	48-5/16	61	64	LSB-536-115	LSB-636-115	36	39-1/16	48-5/16	79	82
LSB-542-107	LSB-642-107	42	45-5/16	54-5/16	69	72	LSB-542-115	LSB-642-115	42	45-5/16	54-5/16	89	92
LSB-548-107	LSB-648-107	48	51-5/16	60-5/16	79	83	LSB-548-115	LSB-648-115	48	51-5/16	60-5/16	100	104
LSB-554-107	LSB-654-107	54	57-5/16	66-5/16	87	91	LSB-554-115	LSB-654-115	54	57-5/16	66-5/16	111	115
LSB-560-107	LSB-660-107	60	63-5/16	72-5/16	95	99	LSB-560-115	LSB-660-115	60	63-5/16	72-5/16	121	125
LSB-572-107	LSB-672-107	72	75-5/16	84-5/16	112	117	LSB-572-115	LSB-672-115	72	75-5/16	84-5/16	143	148

Part number for live shaft bearing 107: 03-00110

Part number for live shaft bearing 115: 03-00115

COMPONENT ACCESSORIES

LIVE SHAFT ROLLERS – 4", 5" & 6" DIAMETER – STEEL AND IMPACT

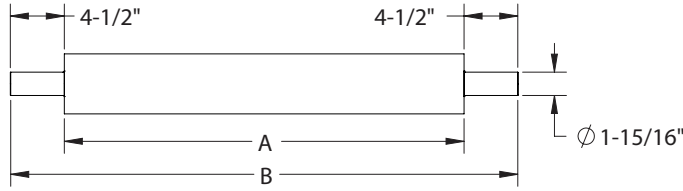

PART NUMBER						BW	A	B
4" DIA	WT (#)	5" DIA	WT (#)	6" DIA	WT (#)			
LS-418	41	LS-518	47	LS-618	54	18	21-5/16	30-5/16
LS-420	44	LS-520	51	LS-620	58	20	23-5/16	32-5/16
LS-424	51	LS-524	58	LS-624	66	24	27-5/16	36-5/16
LS-430	60	LS-530	68	LS-630	79	30	33-5/16	42-5/16
LS-436	69	LS-536	79	LS-636	91	36	39-5/16	48-5/16
LS-442	78	LS-542	89	LS-642	103	42	45-5/16	54-5/16
LS-448	87	LS-548	100	LS-648	115	48	51-5/16	60-5/16
LS-454	97	LS-554	111	LS-654	128	54	57-5/16	66-5/16
LS-460	106	LS-560	121	LS-660	140	60	63-5/16	72-5/16

Note: Impact designated by (LSI-)
Bearings not included but available (03-00115 SCM 1-15/16 bearing and 03-00110 1-7/16" bearing)

SIDE GUIDE IDLERS – 4" X 5-3/8" ROLLERS

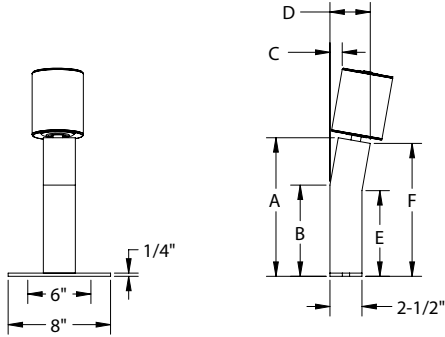

PART NUMBER	BW	A	B	C	D	E	F
42-200020	14-20	9-3/16	7-3/16	11/16	3	6-13/16	8-5/16
42-200036	24-36	11-3/16	8-15/16	3/4	3-1/8	8-9/16	10-5/16
42-200048	42-48	13-7/16	11-3/16	3/4	3-1/8	10-13/16	12-9/16
42-200060	54-60	15-3/16	12-3/4	7/8	3-3/16	12-3/8	14-5/16
42-350030	14-24	12-11/16	10-5/8	1-5/16	3-5/16	10	11-1/4
42-350036	30-36	15-1/4	12-3/8	1-7/8	3-15/16	11-3/4	13-13/16
42-350048	42-48	17-15/16	14-1/8	2-9/16	4-9/16	13-1/2	16-1/2
42-350060	54-60	20-11/16	16	3-1/8	5-3/16	15-3/8	19-1/4

VERTICAL SIDE GUIDE ROLL – 2" & 4" DIAMETER

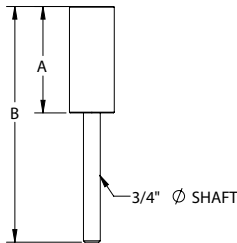

PART NUMBER	A	B	WT (#)
42-020275	2-3/4	9-1/4	2
*46-200004	2-3/4	6-3/4	2
42-020475	4-3/4	10-1/2	3
*46-001247	4-3/4	7-3/4	3
42-604538	5-3/8	7-1/8	5

URETHANE VERTICAL SIDE GUIDE ROLL 3-1/4" DIAMETER

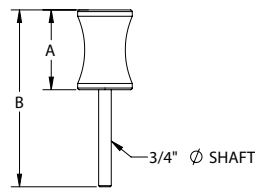

PART NUMBER	A	B	WT (#)
42-325275	2-3/4	9-1/4	5
*42-327275	2-3/4	6-3/4	5
42-325475	4-3/4	10-1/2	8
*42-327475	4-3/4	7-3/4	8

STUB ROLL IDLERS – 4", 5" & 6" DIAMETER

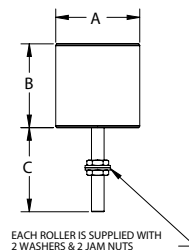

EACH ROLLER IS SUPPLIED WITH 2 WASHERS & 2 JAM NUTS

PART NUMBER	A	B	C	SHAFT	THREAD
*42-404458	4	4	4	17 MM	5/8-18
*42-504458	5	4	4	17 MM	5/8-18
*42-404558	4	4-1/2	4-1/2	17 MM	5/8-18
*42-504558	5	4-1/2	4-1/2	17 MM	5/8-18
*42-404475	4	4	4	3/4	3/4-16
*42-505575	5	5	5	3/4	3/4-16
*42-605575	6	5	5	3/4	3/4-16
*42-405675	4	5	6	3/4	3/4-16
*42-505675	5	5	6	3/4	3/4-16
*42-606675	6	6	6	3/4	3/4-16

* Threaded shaft

OTHER COMPONENTS AVAILABLE

VARIABLE PITCH IDLERS

- The variable pitch idler's outside rollers adjust from 5 to 35 degrees to meet numerous troughing requirements
- Available in CEMA C, D, and E
- SpinGuard® seal technology for long Lasting bearing protection
- Protects the belt from making sharp transitions
- Helps prevent spillage of material as each idler can be adjusted to keep a tight sealing system
- Available in both inline and offset versions
- Inline: Easier to mount on the conveyors initially
- Offset: Minimal roll gap to help prevent belt damage



CEMA C PART NUMBER			CEMA D PART NUMBER		CEMA E PART NUMBER		BW
4"	5"	6"	5"	6"	6"	7"	
C4-VPE-24	C5-VPE-24	C6-VPE-24	D5-VPE-24	D6-VPE-24	–	–	24
C4-VPE-30	C5-VPE-30	C6-VPE-30	D5-VPE-30	D6-VPE-30	–	–	30
C4-VPE-36	C5-VPE-36	C6-VPE-36	D5-VPE-36	D6-VPE-36	E6-VPE-36	E7-VPE-36	36
C4-VPE-42	C5-VPE-42	C6-VPE-42	D5-VPE-42	D6-VPE-42	E6-VPE-42	E7-VPE-42	42
C4-VPE-48	C5-VPE-48	C6-VPE-48	D5-VPE-48	D6-VPE-48	E6-VPE-48	E7-VPE-48	48
C4-VPE-54	C5-VPE-54	C6-VPE-54	D5-VPE-54	D6-VPE-54	E6-VPE-54	E7-VPE-54	54
C4-VPE-60	C5-VPE-60	C6-VPE-60	D5-VPE-60	D6-VPE-60	E6-VPE-60	E7-VPE-60	60
–	–	–	D5-VPE-72	D6-VPE-72	E6-VPE-72	E7-VPE-72	72
–	–	–	–	–	E6-VPE-84	E7-VPE-84	84
–	–	–	–	–	E6-VPE-96	E7-VPE-96	96

WIRE ROPE IDLERS

- Applicable for wire rope and rail type conveyors
- Offset center roller to stabilize idler and to provide zero roll gap so the belt doesn't pinch in the trough
- Includes SpinGuard® seal technology
- Easy clamping method for attaching to wire rope or bolting to rail frame
- Tubular cross member prevents excess build up of material
- Return brackets available
- Available in 35 degree as standard with 27 degree available upon request



CEMA C PART NUMBER		CEMA D PART NUMBER		BW
5"	6"	5"	6"	
C5-35EW-24	C6-35EW-24	–	–	24
C5-35EW-30	C6-35EW-30	–	–	30
C5-35EW-36	C6-35EW-36	D5-35EW-36	D6-35EW-36	36
C5-35EW-42	C6-35EW-42	D5-35EW-42	D6-35EW-42	42
C5-35EW-48	C6-35EW-48	D5-35EW-48	D6-35EW-48	48
C5-35EW-54	C6-35EW-54	D5-35EW-54	D6-35EW-54	54
C5-35EW-60	C6-35EW-60	D5-35EW-60	D6-35EW-60	60
–	–	D5-35EW-72	D6-35EW-72	72

OTHER COMPONENTS AVAILABLE

RUBBER LAGGED CONVEYOR ROLLERS

Long lasting return roller solution in sticky material

- 60 durometer rubber hardness
- 1/4" or 1/2" rubber
- Installed on 4", 5", or 6" rolls
- SpinGuard® seal system
- 18" to 72" belt widths
- Available in CEMA C and D
- Also available installed on troughing and special application rollers



OTHER COMPONENTS

SEALING SYSTEM

- Keeps material from leaking out between belt and hopper skirting.
- Available in several configurations - 5" cartridges, 10" cartridges, or sealing bars available in 4' and 5' lengths.
- Lengths are flexible to customer needs.
- Takes away the sag of the belt between rolls in the conveyor load zone.



REPLACEMENT CARTRIDGE PART NUMBERS

BW	SINGLE PART NUMBERS	
	5"	6"
24	D5S-24-1	D6S-24-1
30	D5S-30-1	D6S-30-1
36	D5S-36-1	D6S-36-1
42	D5S-42-1	D6S-42-1
48	D5S-48-1	D6S-48-1
54	D5S-54-1	D6S-54-1
60	D5S-60-1	D6S-60-1
72	D5S-72-1	D6S-72-1

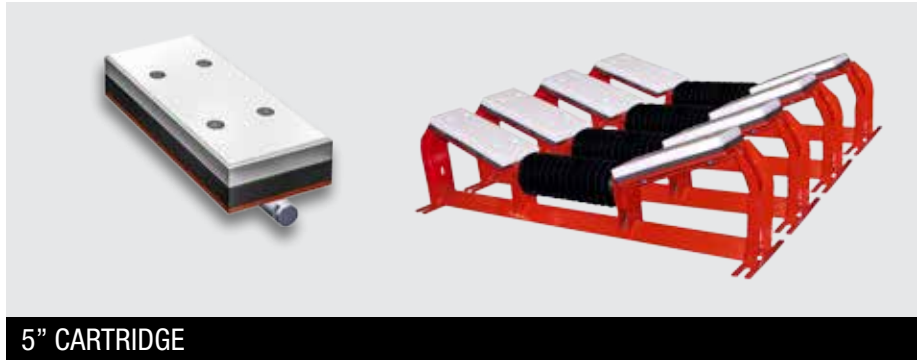

BW	DOUBLE PART NUMBERS	
	5"	6"
24	D5S-24-2	D6S-24-2
30	D5S-30-2	D6S-30-2
36	D5S-36-2	D6S-36-2
42	D5S-42-2	D6S-42-2
48	D5S-48-2	D6S-48-2
54	D5S-54-2	D6S-54-2
60	D5S-60-2	D6S-60-2
72	D5S-72-2	D6S-72-2

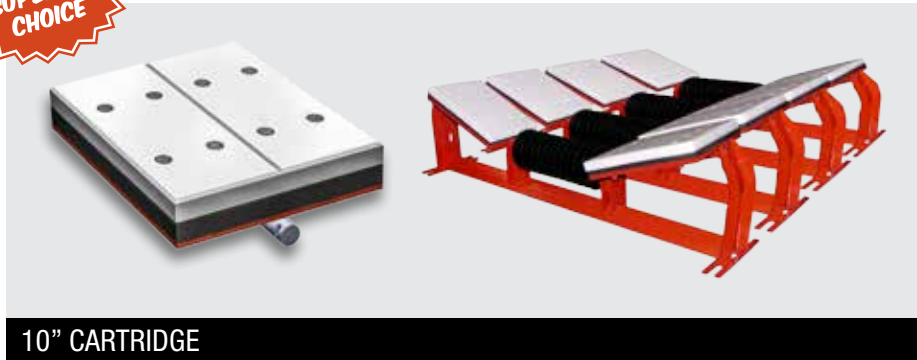

BW	SEAL BAR PART NUMBERS	
	48"	60"
24	38-000026	38-000027
30	38-000026	38-000027
36	38-000026	38-000027
42	38-000026	38-000027
48	38-000026	38-000027
54	38-000026	38-000027
60	38-000026	38-000027
72	38-000026	38-000027



Dimensions of sealing system are similar to the Equal Idlers on pages 5, 11, 30 and 37.

OTHER COMPONENTS

IMPACT BED

Loading area support kit

CEMA C - 5" DIAMETER BARS			
BW	20°	35°	45°
24	I-C5204-241	I-C5354-241	I-C5454-241
30	I-C5204-301	I-C5354-301	I-C5454-301
36	I-C5204-361	I-C5354-361	I-C5454-361
42	I-C5204-421	I-C5354-421	I-C5454-421
48	I-C5204-481	I-C5354-481	I-C5454-481
54	I-C5204-541	I-C5354-541	I-C5454-541
60	I-C5204-601	I-C5354-601	I-C5454-601
72	I-C5204-721	I-C5354-721	I-C5454-721
<hr/>			
24	I-C5205-241	I-C5355-241	I-C5455-241
30	I-C5205-301	I-C5355-301	I-C5455-301
36	I-C5205-361	I-C5355-361	I-C5455-361
42	I-C5205-421	I-C5355-421	I-C5455-421
48	I-C5205-481	I-C5355-481	I-C5455-481
54	I-C5205-541	I-C5355-541	I-C5455-541
60	I-C5205-601	I-C5355-601	I-C5455-601
72	I-C5205-721	I-C5355-721	I-C5455-721

4' Impact Bed

5' Impact Bed

CEMA C - 6" DIAMETER BARS			
BW	20°	35°	45°
24	I-C6204-241	I-C6354-241	I-C6454-241
30	I-C6204-301	I-C6354-301	I-C6454-301
36	I-C6204-361	I-C6354-361	I-C6454-361
42	I-C6204-421	I-C6354-421	I-C6454-421
48	I-C6204-481	I-C6354-481	I-C6454-481
54	I-C6204-641	I-C6354-641	I-C6454-641
60	I-C6204-601	I-C6354-601	I-C6454-601
72	I-C6204-721	I-C6354-721	I-C6454-721
<hr/>			
24	I-Cw205-241	I-C6355-241	I-C6455-241
30	I-C6205-301	I-C6355-301	I-C6455-301
36	I-C6205-361	I-C6355-361	I-C6455-361
42	I-C6205-421	I-C6355-421	I-C6455-421
48	I-C6205-481	I-C6355-481	I-C6455-481
54	I-C6205-641	I-C6355-641	I-C6455-641
60	I-C6205-601	I-C6355-601	I-C6455-601
72	I-C6205-721	I-C6355-721	I-C6455-721

4' Impact Bed

5' Impact Bed



RETURN & FLAT BRACKETS STYLES

CEMA B, C, & D RETURN BRACKETS

*32-000019 4-1/4" Rise Bracket (2.94 lbs)

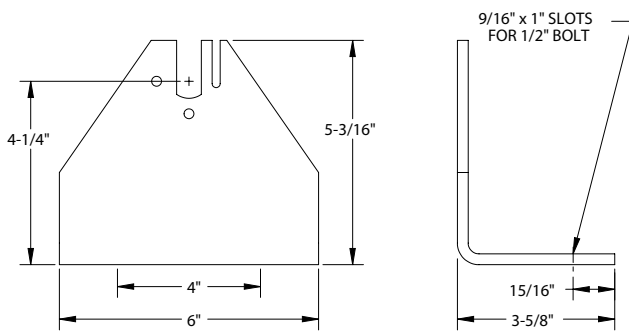

*32-000017 4-1/2" Drop Bracket (1.63 lbs)

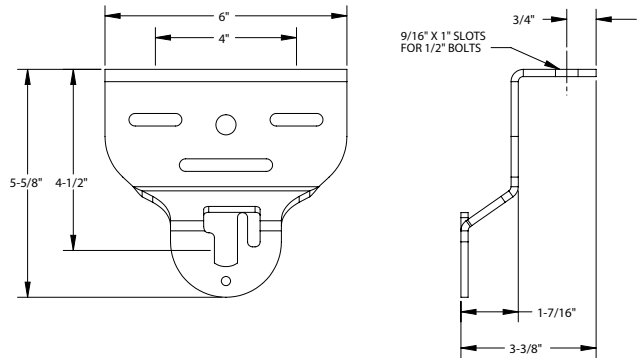

*32-000020 1-1/2" Rise Bracket (1.78 lbs)

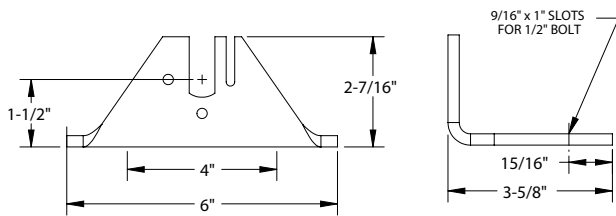

*32-000018 1-1/2" Drop Bracket (0.87 lbs)

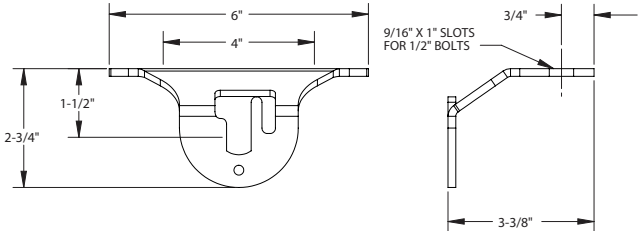

*32-000021 4-1/2" (2.32 lbs)

*32-000022 1-1/2" (2.00 lbs)

Universal Return Roll Bracket

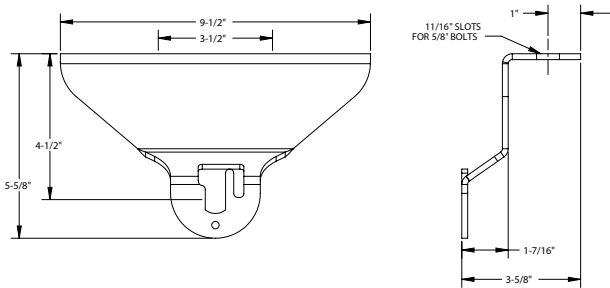

*32-000023 Channel Mount Bracket (2.28 lbs)

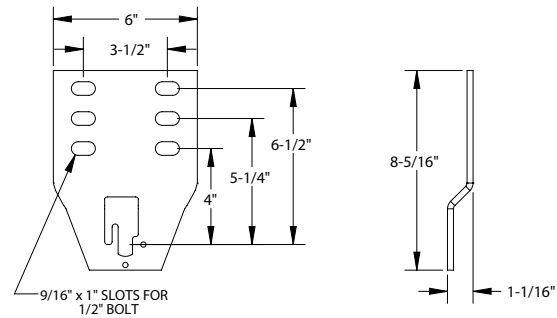

32-010045 CEMA E Rise Bracket (7.22 lbs)

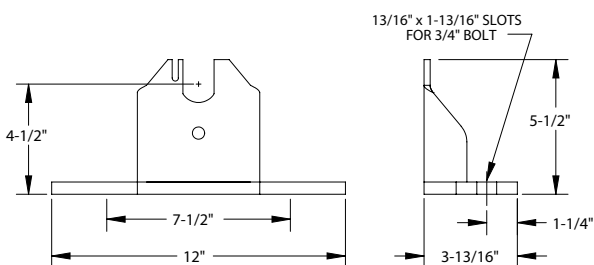

32-010075 CEMA E 7" Drop Bracket (6.52 lbs)

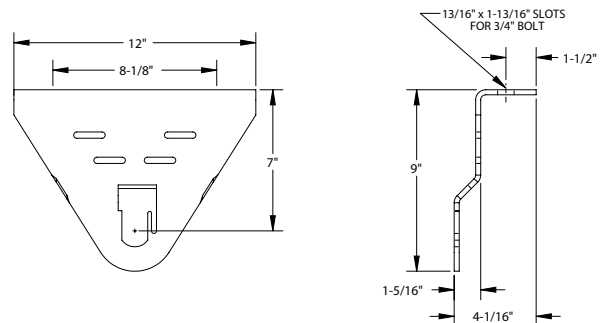

* Part Numbers use hold down kits. The hold down kit part numbers include 13-10076 (CEMA B & C) and 13-10077 (CEMA D).

RETURN & FLAT BRACKETS STYLES

81 & 91 SERIES BRACKETS – HEX

32-000412 4-1/4" Rise Hex Bracket (3.14 lbs)

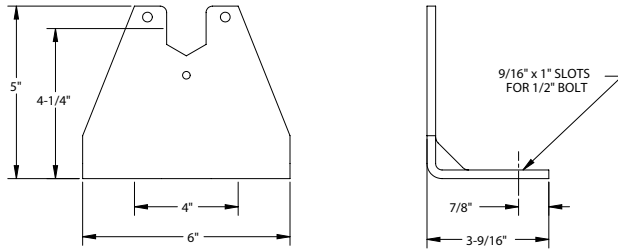

32-014046 4-1/2" Drop Hex Bracket (3.12 lbs)

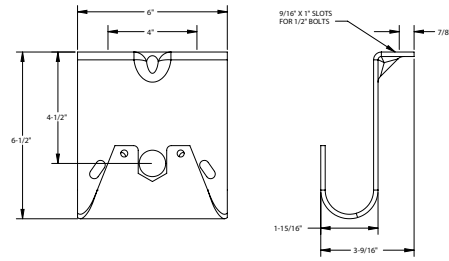

32-011608 1-1/2" Rise Hex Bracket (2.00 lbs)

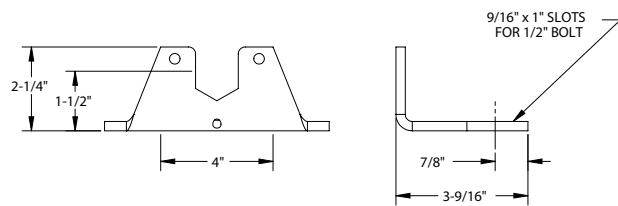

32-015120 1-1/2" Drop Hex Bracket (2.21 lbs)

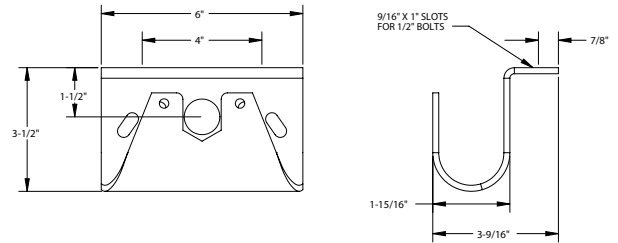

32-410450 4-1/2" CB Bracket (2.10 lbs)

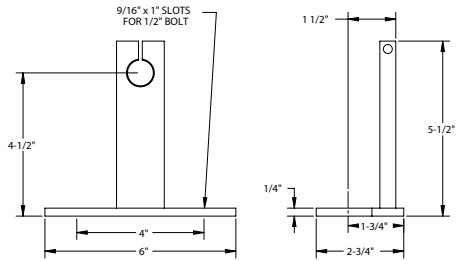

32-506000 CB Channel Mount Hex Bracket (2.00 lbs)

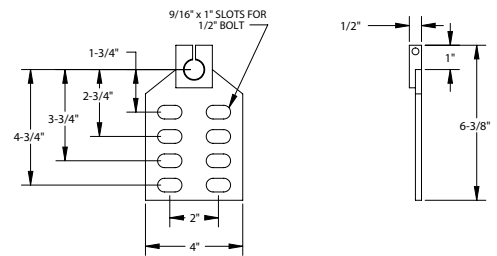

32-044081 1-1/2" CB Bracket (1.40 lbs)

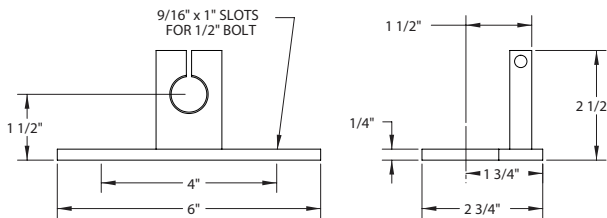

32-044080 CM Channel Mount Hex Bracket (2.00 lbs)

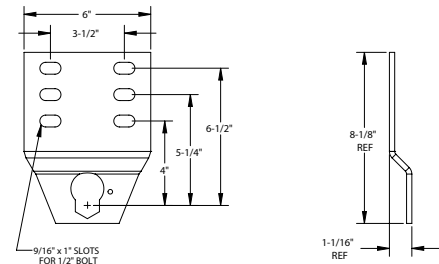

BASE PLATE FOR CEMA B, C, D IDLERS

54"-72" Belt Width CEMA C & D (2.67 lbs)

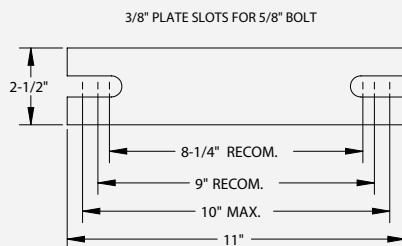

42"-48" BW CEMA B (1.34 lbs)
24-48 BW CEMA C & D

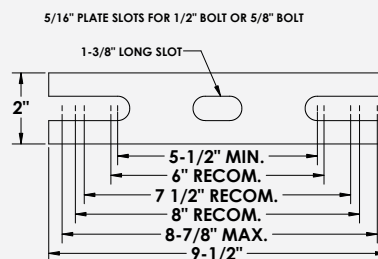

14"-36" BW CEMA B (0.97 lbs)
14"-20" BW CEMA C

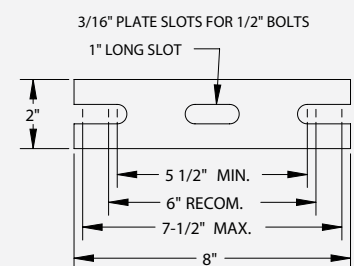

SPECIALIZED DESIGNS

There is no limit to the ingenuity at Superior Components. Superior realizes that each user has considerations specific to their individual applications and we are ready to customize our products for these applications. Superior is able to modify bolt centers, roller heights, roller lengths, shaft styles, and any other idler dimension to fit your application.

To ensure the best quality on all of our conveyor components, all of our idlers are powder coated. Superior is proud to have the quickest deliveries in the industry. Whether you are in need of standard or specially designed idlers and pulleys, Superior can eliminate the hassles of finding the right component for any application. Here are just a few options customers have in custom ordering conveyor components:

- Modified bolt centers
- Neoprene & rubber coating
- Special roller lengths
- Various shaft styles
- Special dimensions
- Wire rope idlers
- Custom return rolls to fit existing brackets
- Special guide idlers
- Scale quality idlers
- Lagged Return Rollers

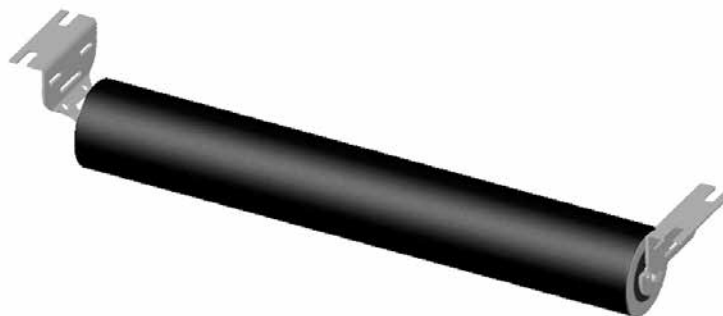
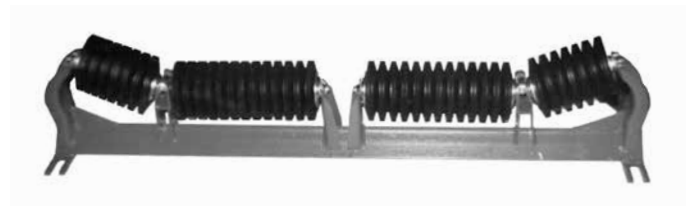

IDLER SELECTION PROCEDURE

Initial Selection; Steps 1, 2, and 3:

Select idler class by comparing calculated idler load with idler load ratings (CIL and CILR) from Tables 2-11 through 2-14. Select impact idler class, if necessary, as shown in Step 3. CEMA idler manufacturers have standard designs meeting these load ratings and dimensional standards shown in tables listed in this publication.

Bearing L10 Life Correction; Steps 4, 5, and 6:

Factors K2 (Fig. 2.5) and K3A (Fig. 2.6) are multiplying factors used to adjust basic L10 life rating of idler class selected. Factor K2 is based on percent of idler load and K3A is factor of actual roll speed (RPM). Factor K3B (Fig. 2.7), step 5 is an optional step showing advantage of using larger diameter rolls. It can be used as a multiplier to save repeating step 5 if a larger diameter roll is used.

Determine Potential Idler Life; Step 7:

Factors K4A (Fig. 2.8), K4B (Fig. 2.9), and K4C (Fig. 2.10) show conditions which will affect idler life and are independent of bearing L10 life, idler load and idler class. Use these figures to evaluate the potential expected idler life.

Step No.1 Troughing Idlers Series Selection

Calculated Idler Load (lbs.) = $CIL = ((WB + (WM \times K1)) \times SI) + IML$

Where:

WB= Belt weight (lbs./ft.) use actual or estimate from Table 2-1

WM= Material weight (lbs./ft.) = $(Q \times 2000) / (60 \times V)$

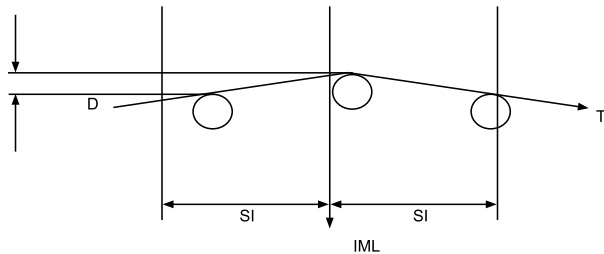

Q= Quantity of material conveyed (Tons per hour)

V= Design belt speed (FPM)

SI= Spacing of idlers (ft.)

K1= Lump adjustment factor (see Table 2-2)

Note: Actual weight of lump should be compared with WM value. In situations it may be necessary to use actual lump weight as WM.

IML= Idler misalignment load (lbs.) due to idler height deviation and belt tension = $(D \times T) / (6 \times SI)$

Where:

D= Misalignment (inches)

T= Belt Tension (lbs.)

SI= Idler Spacing (feet)

When an idler is higher than the adjacent idler, a component of belt tension will add load to that idler. The amount of height deviation can vary with the installation and type of idler. CEMA publication on "Conveyor Installation Standards" (Appendix D, "Belt Conveyors for Bulk Material," Fifth Edition or later) lists recommendations on structure misalignment.

Use CIL and select proper series of idler from Tables 2-11 through 2-14. CIL value should be equal to or less than idler rating.

This troughing idler selection procedure for calculating idler load does not include the following:

1. Impact force on idler at loading points.
2. Effect of belt transitions (head and tail pulley) on idler load.

BELT WIDTH (INCHES (B))	MATERIAL CARRIED, LBS./CU. FT.		
	30-74	75-129	130-200
18	3.5	4	4.5
24	4.5	5.5	6
30	6	7	8
36	9	10	12
42	11	12	14
48	14	15	17
54	16	17	19
60	18	20	22
72	21	24	26
84	25	30	33
96	30	35	38

Table 2-1 WB Estimated average belt weight multiple and reduced ply belts. lbs / ft

1. Steel cable belts increase above value by 50%.
2. Actual belt weights may vary with different constructions, manufacturers, cover gauges, etc. Use the above values for estimating. Obtain actual values from the belt manufacturer whenever possible.

MATERIAL LUMP SIZE (INCHES)	MATERIAL WEIGHT, LBS./CU. FT.						
	50	75	100	125	150	175	200
4	1.0	1.0	1.0	1.0	1.1	1.1	1.1
6	1.0	1.0	1.0	1.1	1.1	1.1	1.1
8	1.0	1.0	1.1	1.1	1.2	1.2	1.2
10	1.0	1.1	1.1	1.1	1.2	1.2	1.2
12	1.0	1.1	1.1	1.2	1.2	1.2	1.3
14	1.1	1.1	1.1	1.2	1.2	1.3	1.3
16	1.1	1.1	1.2	1.2	1.3	1.3	1.3
18	1.1	1.1	1.2	1.2	1.3	1.3	1.4

Table 2-2 K1 Lump Adjustment Factor

Step No. 2 Return idler Series Selection

Calculated Idler Load (lbs.) = $CILR = (WB \times SI) + IML$

Use CILR and select proper series of idler from Tables 2-11 through 2-14. CILR should be equal to or less than return idler rating.

Step No. 3 Impact Idler Series Selection

For homogeneous material without lumps:

Impact Force (lbs.) = $F = (0.1389)Q\sqrt{H}$

Where:

Q= Rate of flow (ST/hr)

H= Height of fall (ft.)

The calculated impact force is then multiplied by an impact idler spacing factor, f (Table 2-3), to determine the impact force on one idler. Unit Impact Force (lbs.) = $F_u = F(f)$

SI IMPACT	FACTOR F
1' 0"	0.5
1' 6"	0.7
2' 0"	0.9
>2' 0"	1

Table 2-3 Impact Idler Spacing Factor

IDLER SELECTION PROCEDURE

Use this unit impact force, F_u , and select proper series of impact idler from Tables 2-11 through 2-14. F_u should be equal to or less than idler rating.

For material containing large lumps:

$$\text{Impact Force (lbs.)} = F = W + (2kWH)^{1/2}$$

Where:

W = Weight of lump (lbs.)

H = Height of fall (ft.)

k = Spring constant for specific idler type (lbs./ft.)

Use calculated energy rating, WH , and maximum lump size to select proper series of impact idler from Table 2-4. Both WH and lump size should be equal to or less than energy rating and maximum lump size.

Note: Both cases (material without lumps and material containing large lumps) should always be considered and the heavier duty idler selected to insure adequate impact resistance capabilities.

3-ROLL RUBBER IMPACT IDLERS (EQUAL LENGTH ROLLS)		
CEMA SERIES	WH (LBS.-FT.)	MAXIMUM LUMP SIZE (IN.)
B	40	4
C	160	6
D	240	8
E	460	12

Table 2-4 Energy Ratings for Impact Idlers

Step No. 4 K2 = Effect of load on predicted bearing L10 life.

When Calculated Idler Load (CIL) is less than CEMA load rating of series idler selected, the bearing L10 life will increase.

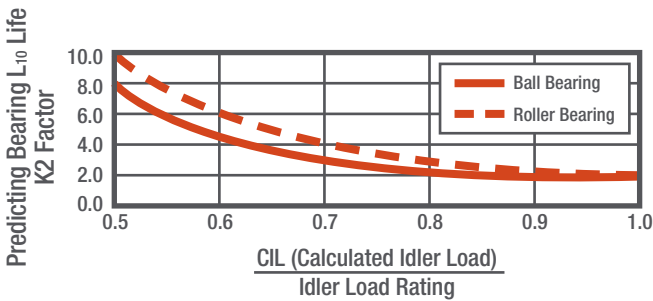

Figure 2-5 Effect of Load on Predicted Bearing L10 Life

Step No. 5 K3A = Effect of belt speed on predicted bearing L10 life

CEMA L10 life ratings are based on 500 rpm. Slower speeds increase life and faster speeds decrease life. Figure 2-6 shows this relationship.

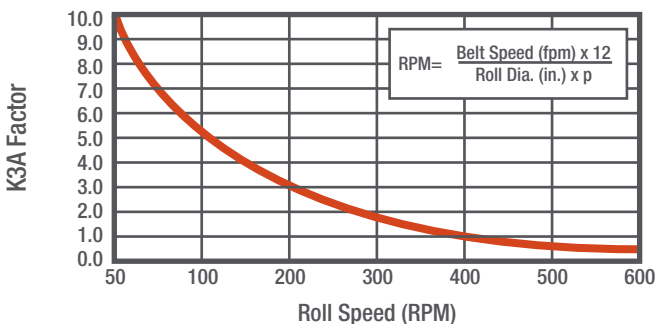

Figure 2-6 Effect of Belt Speed on Predicted Bearing L10 Life

Step No. 6 K3B= Effect of roll diameter on predicted bearing L10 life

For a given belt speed, using larger diameter rolls will increase idler L10 life adjustments for various roll diameters using 4" diameter as a value of 1.0. Percent life increase can be calculated for each roll diameter increase.

Example: 1.5 for 6" diameter or 1.25 for 5" diameter= 1.20 or 20% increase in L10 life.

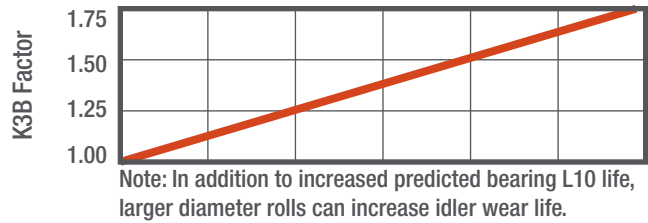

Figure 2-7 K3B= Effect of Roll Diameter on Predicted Bearing L10 Life (Based on the same belt speed)

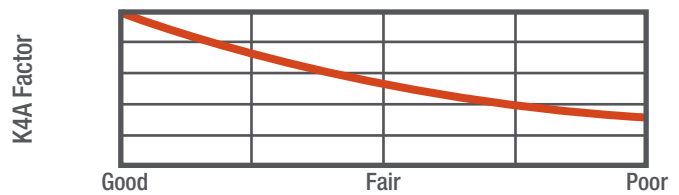

Figure 2-8 K4A= Effect of maintenance on potential idler life

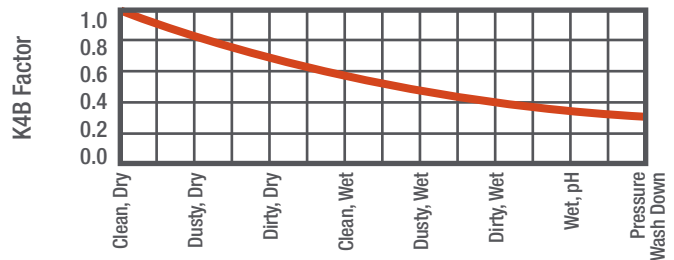

Figure 2-9 K4B= Effect of environment on potential idler life

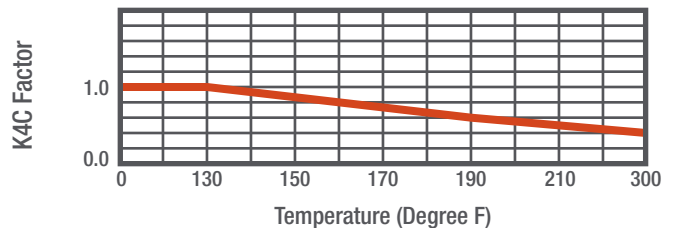

Figure 2-10 K4C= Effect of operating temperature on potential idler life

Based on collective application experience by CEMA idler manufacturers these conditions are very important in determining potential idler life. However, the exact mathematical basis is very subjective so contact your CEMA idler manufacturer for assistance or for any unusual conditions not listed.

BELT WIDTH (INCHES)	TROUGHED ANGLE			SINGLE ROLL RETURN
	20°	35°	45°	
18	410	410	410	220
24	410	410	410	190
30	410	410	410	165
36	410	410	396	155
42	390	363	351	140
48	381	353	342	125

Figure 2-11 Load ratings for CEMA B Idlers, LBS

Ratings based on Min. L10 of 30,000 hours at 500 RPM

IDLER SELECTION PROCEDURE

BELT WIDTH (INCHES)	TROUGHED ANGLE			SINGLE ROLL RETURN	TWO ROLL VEE RETURN
	20°	35°	45°		
18	900	900	900	475	
24	900	900	900	325	500
30	900	900	900	250	500
36	900	837	810	200	500
42	850	791	765	150	500
48	800	744	720	125	500
54	750	698	675	*	500
60	700	650	630	*	500
66				*	500

Figure 2-12 Load ratings for CEMA C Idlers, LBS

Ratings based on Min. L10 of 30,000 hours at 500 RPM
*CEMA D Return Idler

BELT WIDTH (INCHES)	TROUGHED ANGLE			SINGLE ROLL RETURN	TWO ROLL VEE RETURN
	20°	35°	45°		
24	1200	1200	1200	600	
30	1200	1200	1200	600	
36	1200	1200	1200	600	850
42	1200	1200	1200	500	850
48	1200	1200	1200	425	850
54	1200	1116	1035	375	850
60	1150	1070	1035	281	850
66				215	850
72	1050	977	945	155	850
78				125	850

Figure 2-13 Load ratings for CEMA D Idlers, LBS

Ratings based on Min. L10 of 60,000 hours at 500 RPM

BW (IN.)	TROUGHED ANGLE			SINGLE ROLL RETURN	BW (IN.)	TROUGHED ANGLE			SINGLE ROLL RETURN
	20°	35°	45°			20°	35°	45°	
36	1800	1800	1800	1000	72	1800	1800	1800	700
42	1800	1800	1800	1000	78				625
48	1800	1800	1800	1000	84	1800	1674	1620	550
54	1800	1800	1800	925	90				475
60	1800	1800	1800	850	96	1750	1628	1575	400
66				775	102				250

Figure 2-14 Load ratings for CEMA E Idlers, LBS

BELT WIDTH (INCHES)	TROUGHED ANGLE			SINGLE ROLL RETURN
	20°	35°	45°	
60	3000	3000	3000	1500
72	3000	3000	3000	1200
84	3000	3000	3000	900
96	2800	2800	2800	600

Figure 2-15 Load ratings for CEMA F Idlers, LBS

CEMA D & E ratings based on Min. L10 of 60,000 hours at 500 RPM

Notes for tables 2-11 through 2-16

1. Troughing idler load ratings are for three equal length rolls.
2. Load ratings also apply for impact rolls.
3. Troughing idler load ratings are based on a load distribution of 70% on center roll and 15% on each end roll for all trough angles.

BELT WIDTH	CEMA C	CEMA D	CEMA E
24	475	600	-
30	475	600	-
36	325	600	1260
42	250	600	1200
48	200	530	1000
54	150	440	1000
60	125	400	1000
66	-	-	1000
72	-	280	925
84	-	-	775
96	-	-	625

Figure 2-16 Load ratings for CEMA Picking Idlers, LBS

CEMA D & E ratings based on Min. L10 of 60,000 hours at 500 RPM

BELT WIDTH	CEMA C	CEMA D	CEMA E
18	1200	-	-
24	1200	1400	2100
30	1200	1400	2100
36	1200	1400	2100
42	1100	1400	2100
48	1000	1275	2100
54	875	1150	2100
60	780	1000	2100
72	-	850	2100
84	-	-	1825
96	-	-	1550

Figure 2-17 Load ratings for CEMA Live Shaft Idlers, LBS

Belt Carrying Capacity

The carrying capacity of a belt conveyor depends upon belt width, belt speed, and idler troughing configuration. The following information and charts will help you in selecting the proper size and style of idler.

- Define the material and its characteristics: Refer to Table 1 for weights in Lbs per Cu. Ft. and surcharge angles for some bulk materials.
- Select belt speed: Refer to Table 2 for maximum recommended belt speeds. The most economical selection usually dictates the use of maximum belt speeds.
- Select required belt width: Using Table 3 and the correct surcharge angle for the material being handled, select a belt width. Table 3 gives theoretical carrying capacities with various belt widths and idler troughing angles. Table 3 is based on a belt speed of 100 FPM and a material weight of 100 lbs. Per Cu. Ft. Footnote (1) on the bottom of page 74 tells how to calculate the capacities for other belt speeds and material weights. When determining belt width, belt speed, and troughing configuration, select the narrowest belt that will handle the largest material lumps and transport the required capacity without exceeding the maximum recommended belt speed.

Troughing Training

Self-aligning idlers operate effectively when empty belt tensions are 200-lbs./in. or less. When empty belt tensions exceed this range, the belt becomes too stiff and makes training difficult. Belt loaded at high tensions and which generate detraining forces due to off-loading cannot be re-aligned with self-aligning idlers. Self-aligning idlers work effectively at low belt tensions to overcome small amounts of idler skew, which make narrow belts easier to train. Self-aligning idlers are especially needed on low tension reversible belts. Conveyor belts that are 48" and wider usually do not need self-aligning idlers even at low belt tensions because the weight of the belt has more training force than is obtainable with a trainer.

* The removal of one return idler on each side of a self-aligning return to increase conveyor belt wrap on the idler will increase its self-aligning capacity. An alternative in removing the return idlers is to raise the self-aligner above the return belt line.

IDLER SELECTION PROCEDURE

TABLE 1 - CHARACTERISTICS OF COMMON BULK MATERIALS

MATERIAL	WEIGHT (LBS/FT ³)	SURCHARGE ANGLE °	MAX. CONVEYING ANGLE °
Ashes, Coal, Dry, - 3"	35-40	25-30	22
Cement, Portland	90-100	25	20
Cement, Clinker	75-80	20	18
Coal, Arthracite, Sized, 3/8"- 6"	55	12	16
Coal, Bitum., Slack	50	22	22
Coal, Bitum., ROM	50	20	18
Coke, Loose	25-30	15	20
Earth, Common, Loam, Dry	70-80	15-30	20
Earth, Clay, Dry	100-120	10-30	20
Earth, Moist	80-100	30	22
Gravel, Average, Blended	90-100	15-20	18
Gravel, Sharp	90-100	25	20
Gravel, Rounded	90-100	15	15
Iron Ore	135	20	22
Limestone, Crushed	85-90	25-30	20
Phosphate Rock	75-85	25	20
Salt, Coarse, Dry	40-45	10	20
Salt, Fine, Dry	70-80	15	22
Sand, Bank, Damp	110-120	20-30	22
Sand, Bank, Dry	90-110	10-20	15
Sand, Foundry, Shakeout	90	25	20
Sand, Silica, Dry	90-100	10-20	15
Sand, Saterated	110-130	0-15	15
Shale, Crushed	85-90	25	20
Slag, Furnace, Crushed	85-90	12	18
Slate, Crushed, - 1/2"	80-90	15	20
Soda Ash, Light	25-35	22	20
Soda Ash, Heavy	55-65	17	20
Sulphur, Crushed, - 1/2"	50-65	20	20
Sulphur, Lumpy, - 3"	80-85	25	20
Wheat	45-48	8-15	16
Wood Chips	15-25	30	25

TABLE 2 - MAX RECOMMENDED BELT SPEEDS

MATERIAL BEING CONVEYED	BELT SPEEDS (FPM)	BELT WIDTH (IN.)
Grain or other free-flowing, nonabrasive material	400	18
	600	24-30
	800	36-42
	1000	48-96
Coal, damp clay, soft ores, overburden and earth, fine-crushed stone	600	18
	800	24-36
	1000	42-60
	1200	72-96
Heavy, hard, sharp-edged ore, coarse-crushed stone	400	18
	600	24-36
	800	Over 36
Foundry sand, prepared or damp; shakeout sand with small cores, with or without small castings (not hot enough to harm belting)	350	Any Width
Prepared foundry sand and similar damp (or dry abrasive) materials discharged from belt by rubber-edged plows	200	Any Width
Nonabrasive materials discharged from belt by means of plows - except wood pulp, where 300 to 400 preferable	200	Any Width
Feeder belts, flat or troughed, for feeding fine, nonabrasive, or mildly abrasive materials from hoppers and bins.	50 to 100	Any Width

Note: When self-aligning return idlers are used, they should be no closer than 12 belt widths from terminals and should not be located on vertical curves.

INDOOR FOR WIND AND RAIN

In line at standard spacing (Returns removed to obtain maximum training)	200 ft. 150 ft.	150 ft. 75-100 ft.
---	--------------------	-----------------------

SUGGESTED SPACING OF TROUGHING IDLERS

BELT WIDTH (INCHES)	WEIGHT OF MATERIAL HANDLED (LBS/FT ³)						RETURN IDLERS
	30	50	75	100	150	200	
18	5.5	5.0	5.0	5.0	4.5	4.5	10.0
24	5.0	4.5	4.5	4.0	4.0	4.0	10.0
30	5.0	4.5	4.5	4.0	4.0	4.0	10.0
36	5.0	4.5	4.0	4.0	3.5	3.5	10.0
42	4.5	4.5	4.0	3.5	3.0	3.0	10.0
48	4.5	4.0	4.0	3.5	3.0	3.0	10.0
54	4.5	4.0	3.5	3.5	3.0	3.0	10.0
60	4.0	4.0	3.5	3.0	3.0	3.0	10.0
72	4.0	3.5	3.5	3.0	2.5	2.5	8.0
84	3.5	3.5	3.0	2.5	2.5	2.0	8.0
96	3.5	3.5	3.0	2.5	2.0	2.0	8.0

TABLE 3 MAXIMUM BELT CAPACITIES

BW (IN.)	TROUGHED ANGLE	MAX BELT CAPACITY (TPH)					MAX. MATERIAL (IN.) FOR 20° SURCHARGE		
		SURCHARGE ANGLE					ALL LUMPS UNIFORM SIZE	MIXED 10% LUMPS 90% FINES	
		5°	10°	20°	25°	30°			
18	20°	-	-	50	56	63	4	4	
	35°	Not Recommended							
	45°	Not Recommended							
24	20°	-	-	96	108	120	5	7	
	35°	-	102	122	132	142	5	7	
	45°	106	115	132	140	170	5	7	
30	20°	-	-	157	175	195	6	10	
	35°	-	167	200	215	232	6	10	
	45°	175	187	215	230	244	6	10	
36	20°	-	-	230	260	290	7	12	
	35°	-	248	295	318	343	7	12	
	45°	258	278	318	340	360	7	12	
42	20°	-	-	320	360	400	8	14	
	35°	-	344	408	442	475	8	14	
	45°	358	386	440	470	500	8	14	
48	20°	-	-	430	480	530	10	16	
	35°	-	457	540	645	630	10	16	
	45°	475	510	584	623	660	10	16	

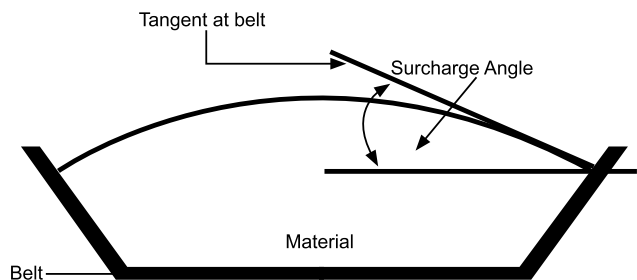

1. All capacities shown are for material weighing 100 lbs. per cu. ft. and moving on belt 100fpm. For other weights, capacity equals table capacity.

$$\times \frac{\text{Wt./Cu. Ft.}}{100}$$

For other belt speeds, capacity equals table capacity (or calculated capacity).

$$\times \frac{\text{fpm}}{100}$$

2. The surcharge angle is the angle formed between a horizontal line and a tangent to the material slope, both of which pass through the point where the slope meets the belt. Usually the surcharge angle is 10°-15° less than the angle of repose.

3. "Mixed with 50% fines" means at least half of the material must be less than one half the maximum material size.

TERMS AND CONDITIONS

SUPERIOR INDUSTRIES, LLC (d/b/a Superior Equipment and as Superior Components)

1. **OFFER AND ACCEPTANCE.** Superior Industries, LLC's ("Seller") acceptance of Buyer's order to purchase products is expressly made conditional on assent to these Terms and Conditions, which along with the Sales Order constitute a binding "Contract" between the parties. This Contract constitutes the complete and final agreement between Seller and Buyer for the products. Any additional or different terms or conditions contained in any document furnished by Buyer, including but not limited to, any purchase order or any acknowledgment, are deemed to be material and are hereby objected to and rejected by Seller. If such agreement shall be deemed an offer or counter-offer by Buyer, Seller expressly rejects such offer or counter-offer and limits acceptance to these Contract terms and expressly objects to any different or additional terms proposed by Buyer. Any actual performance by Buyer or Seller thereafter shall be deemed a renewal of the offer contained in this Contract and acceptance of this Contract without change. In the event of a conflict between the terms of this Contract and the terms of any other document, the terms of this Contract shall control. This offer to purchase Seller's products is valid for thirty (30) days from the date of the Sales Order.

2. **PAYMENT TERMS.** All prices specified in this Contract are FOB Seller's designated location which constitutes delivery. All risk of damage to or loss of the products from any cause whatsoever shall pass to Buyer upon delivery, even if Seller arranges for shipment of the product. Unless otherwise expressly provided on the reverse hereof, payment shall be made within thirty (30) days from the earlier of the date of delivery or the date of an invoice, without discount. Any discount which may be expressly provided on the reverse hereof applies to the sale price of the products at the shipping point, and does not apply to any charges made for taxes, storage, loading or transportation. All payments shall be made in United States dollars. Interest will be charged at the rate of eighteen percent (18%) per annum, or the maximum interest rate allowable by applicable law, whichever is lower, on all unpaid invoices. Buyer shall pay all taxes and charges of any nature imposed by any federal, state, or local governmental authority by reason of the sale or delivery of the products whether levied or assessed against Seller, Buyer, or the products. Such applicable taxes or charges, if not included in this Contract, shall be invoiced separately. If, in Seller's opinion, reasonable doubt exists as to Buyer's financial condition, Seller may, at any time and without prejudice to any other remedies, suspend or terminate performance of any order, decline to ship, stop any material in transit, or require full or partial payment by Seller in advance.

3. **DELIVERY.** Any delivery or promise date indicated on the Sales Order is an estimate of the date Seller believes the products will be available for delivery, provided, however, Seller shall not be responsible for any delays in delivery.

4. WARRANTY.

a. **Limited Warranty; Exclusion of Third Party Components.** Subject to the terms, conditions and limitations contained herein, Seller warrants only to the original Buyer that (a) Seller's new equipment products and Seller's new component products will not fail to operate in accordance with their respective specifications due to defects in material or workmanship during the period which ends two (2) years from the date of delivery, normal wear and tear excluded, and (b) Seller's new equipment products will not incur a failure of their respective structural components (i.e., trusses) due to defects in material or workmanship at any time during the period which ends five (5) years from the date of delivery, normal wear and tear excluded. The foregoing periods are sometimes referred to as "original warranty periods." The foregoing limited warranty does not apply to any part, portion or component of any product which is manufactured by a third-party ("Third-Party Component").

b. **DISCLAIMER OF ALL OTHER WARRANTIES, EXPRESS, IMPLIED OR STATUTORY. THE LIMITED WARRANTY SET FORTH IN THE FOREGOING PARAGRAPH IS THE SOLE AND EXCLUSIVE WARRANTY WITH RESPECT TO THE PRODUCTS. SELLER MAKES NO OTHER EXPRESS WARRANTY OF ANY KIND OR NATURE AS TO THE PRODUCTS OR THEIR PERFORMANCE EXCEPT FOR THOSE LIMITED WARRANTIES EXPRESSLY SET FORTH IN THE FOREGOING PARAGRAPH AND SPECIFICALLY DISCLAIMS ANY AND ALL REPRESENTATIONS OR WARRANTIES OF ANY KIND OR NATURE CONCERNING THE PRODUCTS, INCLUDING, BUT NOT LIMITED TO, ANY REPRESENTATION OR WARRANTY THAT THE PRODUCTS COMPLY WITH ANY LAW, RULE OR REGULATION. SELLER MAKES NO WARRANTIES WITH RESPECT TO ANY THIRD PARTY COMPONENT AND SELLER SPECIFICALLY SELLS SUCH THIRD-PARTY COMPONENTS "AS IS" WITHOUT ANY WARRANTY. FURTHER, SELLER MAKES NO IMPLIED WARRANTY OF ANY KIND OR NATURE WITH RESPECT TO ITS PRODUCTS OR ANY THIRD-PARTY COMPONENT AND SPECIFICALLY DISCLAIMS ANY AND ALL IMPLIED WARRANTIES, INCLUDING, BUT NOT LIMITED TO, ANY AND ALL IMPLIED WARRANTIES OF MERCHANTABILITY, FITNESS FOR A PARTICULAR PURPOSE, NON-INFRINGEMENT, OR COMPLIANCE WITH ANY FEDERAL, STATE OR LOCAL LAW, RULE OR REGULATION. IN ADDITION, SELLER EXPRESSLY DISCLAIMS TO THE FULLEST EXTENT ALLOWED BY LAW, RULE OR REGULATION ANY WARRANTY PROVIDED UNDER ANY FEDERAL, STATE OR LOCAL LAW, RULE OR REGULATION.**

c. **Terms and Conditions of Warranty; Voiding of Warranty; Notice Requirements.** The limited warranties set forth above shall be null and void if (a) any alterations or modifications are made to a product, (b) a product is not maintained in strict compliance with the maintenance requirements set forth in the maintenance manual for such product or otherwise provided to Buyer of such product, (c) any repairs are made to a product which are not authorized by Seller in writing, (d) any failure of a product to comply with the above limited warranty is not reported to Seller in writing within thirty (30) days of the date such failure first occurs, (e) a product is operated after the failure of any warranty first occurs, (f) a product is used for any purpose other than for the purpose for which it was manufactured, (g) a product is not operated in strict compliance with the terms and conditions set forth in any operating manual for the product (including but not limited to exceeding the load bearing capacity of the product), (h) a product is abused or damaged, (i) Buyer fails to deliver the product to Seller for inspection and testing if requested by Seller or Buyer disposes of the product or any part or component on or before the sixtieth (60th) day after sending a written claim under the warranty to Seller, or (j) such failure of the limited warranty results from a failure of any Third-Party Component.

d. **Course of Dealing; Course of Performance; Usage of Trade.** No course of dealing or course of performance of Seller with respect to the products sold under this Contract or with respect to any of its products to whom ever sold and no usage of trade shall be considered in interpreting this Contract or any part thereof and none of the foregoing shall be considered a waiver or modification of any such terms, conditions, disclaimers or limitation of the limited warranties or disclaimers contained in this Contract. No statement, whether written or oral, made by any employee, sales person, distributor, agent or contractor of Seller which is not set forth in this Contract shall be considered a representation or warranty with respect to any product, its specifications or its performance and all such statements are hereby disclaimed.

e. **Exclusive Remedies for Breach of Warranty.** The sole and exclusive remedy for any failure of any product to comply with the limited warranty set forth above or any other warranty imposed upon Seller by law, if any, shall, at the election of Seller, in its sole discretion, be either (a) the repair or replacement of the product or component which failed to comply with such warranty or (b) the refund of the purchase price of the product. Buyer is responsible for all labor costs in connection with the repair or replacement of any equipment or component product; however, Seller will be responsible for its own labor performed in connection with any repair of equipment products at Seller's location. Except as provided below, any repair or replacement shall carry the same warranty as the original product but only for the remainder of the original warranty period.

Buyer's exclusive remedy with respect to any claim arising out of or as a result of Third-Party Component shall be against the third-party manufacturer.

f. **Warranty Claims; Notice Requirement; Limited Time to Bring Claims.** Any and all claims under the above limited warranty shall be made to Seller only in writing and not later than thirty (30) days after the date the product first fails to comply with the above limited warranty but in no event later than the expiration of the original warranty period with respect to which the claim is being made. Any claim under the above limited warranty made after such period for making a claim shall be null and void. After receiving written notice of the warranty claim, Seller shall determine whether to (a) repair or replace the product or part or (b) refund the purchase price of the product. Seller may require Buyer to return any product or part thereof which Buyer claims to be defective to Seller at Buyer's cost for inspection as a condition to any claim under the above limited warranty. No product or part may be returned to Seller without Seller's prior written authorization. If a product which is returned is determined by Seller in its sole discretion not to have failed to comply with the limited warranty, Buyer shall pay costs of removal, repair and/or replacement for such product. If a product which is returned is determined by Seller in its sole discretion to have failed to comply with the limited warranty, Seller shall pay for all repair and/or replacement costs for such product (or refund the purchase price if so elected by Seller) and Seller shall reimburse Buyer for the reasonable costs of shipping the product or component to Seller.

TERMS AND CONDITIONS

g. **Limitation on Liability for Breach of Warranty and Other Claims.** If the warranty and the remedy for any failure of any product to comply with any warranty are deemed for any reason to fail their intended purpose, Seller's liability for any failure of any product to comply with any such warranty, together with any and all other liability, if any, arising out of or in connection with such product, including, but not limited to, all claims, whether in contract, tort, or otherwise, arising out of, connected with, or resulting from the manufacture, sale, delivery, resale, repair, replacement, or use of the product, shall not exceed the purchase price for such product. In no event shall Seller be responsible or liable to Buyer or any third party under any circumstances for any indirect, consequential, special, punitive or exemplary, damages or losses, including, but not limited to, damages for loss of profits, goodwill, use of the product or any other equipment or other intangible losses which may be incurred in connection with the product regardless of the type of claim or the nature of the cause of action, even if Seller has been advised of the possibility of such damage or loss. Any and all claims that Buyer has against Seller, whether or not Buyer is aware of such claims, must be brought by Buyer within thirty (30) days after the date that such claim first arose, but in any event within the applicable warranty period set forth above. Any claim not brought by Buyer within the applicable thirty (30) day period shall be deemed null and void.

5. **INDEMNIFICATION.** Buyer will indemnify and hold harmless Seller, its affiliates and their respective officers, directors, employees, agents and other representatives and defend any action brought against same with respect to any claims, judgments, actions, suits, demands, damages, liabilities, costs or expenses (including, but not limited to, reasonable attorneys' fees and legal expenses) associated with or arising from the ownership, use or operation of the products by Buyer or any third party, including without limitation, product liability, an international, federal or state occupational safety and health statute, or any other governmental regulations or laws.

6. **TERMINATION OF PERFORMANCE.** Buyer may cancel its order only with the written consent of Seller and upon terms that will indemnify Seller from any loss, damage and expense arising from such cancellation. Seller may terminate this Contract pursuant to Sections 2 and/or 11 hereof, and in such event, Seller shall have no further liability to produce or ship any products hereunder and shall have no liability for damages to Buyer or any third party.

7. **TECHNICAL ADVICE.** No obligation or liability shall arise out of Seller's rendering of technical advice in connection with Buyer's order of products. Any technical advice furnished, or recommendation made by Seller or any employee or representative of Seller, concerning any use or application of any products or parts furnished under this Contract is believed to be reliable, but Seller makes no warranty, express or implied, of results to be obtained. Buyer assumes all responsibility for loss or damage resulting from the handling or use of any such products or parts in accordance with such technical advice or recommendation. The selection of the products ordered, or design of any custom products, shall be Buyer's sole and ultimate responsibility, and Seller shall have no liability whatsoever for any design defects of custom products, or if the products ordered are unsuitable for Buyer's intended use. Any advice or assistance provided by Seller to Buyer in connection with Buyer's selection or design of the products is at Buyer's risk, and Seller makes no representation or warranty whatsoever in connection with such advice or assistance.

8. **ASSIGNMENT.** Buyer shall not assign its rights or obligations under this Contract without the prior written consent of Seller, which consent may be withheld for any reason in the sole discretion of Seller. Any attempt at such assignment by Buyer without the prior written consent of Seller shall be deemed null and void. This Contract will be binding upon the parties hereto, and their successors and permitted assigns.

9. **SECURITY INTEREST OF SELLER.** Title to the products will not pass to Buyer until all required payments have been made to Seller. Until the purchase price and all other applicable costs and expenses are paid in full, Seller reserves a purchase money security interest in the products and the proceeds therefrom, and Seller thereby possesses the rights of a secured party under the Uniform Commercial Code. Upon Seller's request, Buyer shall execute all necessary financing statements and other documents evidencing this security interest with the appropriate state and local authorities. Seller is entitled to and is hereby granted reasonable access to Buyer's locations as necessary to exercise its remedies as a secured party.

10. **GOVERNING LAW.** This Contract shall be construed, interpreted, and governed by the laws of the State of Minnesota without regard to its conflict of laws principles. The exclusive forum for any disputes arising out of or relating to this Contract shall be any federal or state court sitting in the State of Minnesota. The parties irrevocably consent to such exclusive jurisdiction in such courts and to the proper venue therein.

11. **FORCE MAJEURE.** Seller does not assume the risk of and shall not be liable for failure to perform any obligation relating to the products caused by civil insurrection, war, fire, strike, labor stoppages or other labor disturbances, acts of God, acts or omissions of Buyer, acts or omissions of the United States Government, floods, epidemics, freight embargoes, shortages of fuel, energy or materials, failure of suppliers or subcontractors to satisfactorily meet scheduled deliveries, or any other cause beyond the reasonable commercial control of Seller.

12. **NOTICES.** Any notices, consents or other communications required or permitted under this Contract must be in writing and delivered personally, overnight air courier, registered or certified mail or facsimile. Unless otherwise stated in this Contract, notices, consents or other communication will be deemed received (a) on the date delivered, if delivered personally or by facsimile transmission; (b) on the next business day if sent via overnight air courier; or (c) three (3) business days after being sent, if sent by registered or certified mail.

13. **SEVERABILITY; WAIVER.** The invalidity or unenforceability of any provision of this Contract shall not affect the validity or enforceability of any other provision of this Contract. No waiver of any of the provisions of this Contract shall be deemed, or shall constitute a waiver of any other provision, whether or not similar, nor shall any waiver constitute a continuing waiver. No waiver shall be binding unless executed in writing by the party making the waiver. The Section headings included herein are for the convenience of the parties only and in no way alter, modify, amend, limit or restrict the contractual obligations of the parties.

14. **NO THIRD-PARTY BENEFICIARIES; SETOFF.** Nothing in this Contract is intended to, or shall, create any third-party beneficiaries, whether intended or incidental, and neither party shall make any representations to the contrary. Seller shall have the right to deduct from any sums it owes to Buyer, any sums or the value of any obligation owed by Buyer to Seller.

15. **ENTIRE AGREEMENT.** The terms set forth herein constitute the sole terms and conditions of the Contract between Buyer and Seller. Notwithstanding the foregoing or any other term of this Contract, to the extent this Contract conflicts with the terms or conditions of any written distributor agreement between the parties, the written distributor agreement shall control. No other warranty, term, condition or understanding, whether oral or written shall be binding upon Seller, unless hereafter expressed in writing, approved and signed by Seller.

16. **SURVIVAL.** The provisions of Sections 3, 4, 5, and 7 through 16 shall survive the termination and performance of this Contract.

ANATOMY OF A SUPERIOR IDLER



Hex Nut Adaptor

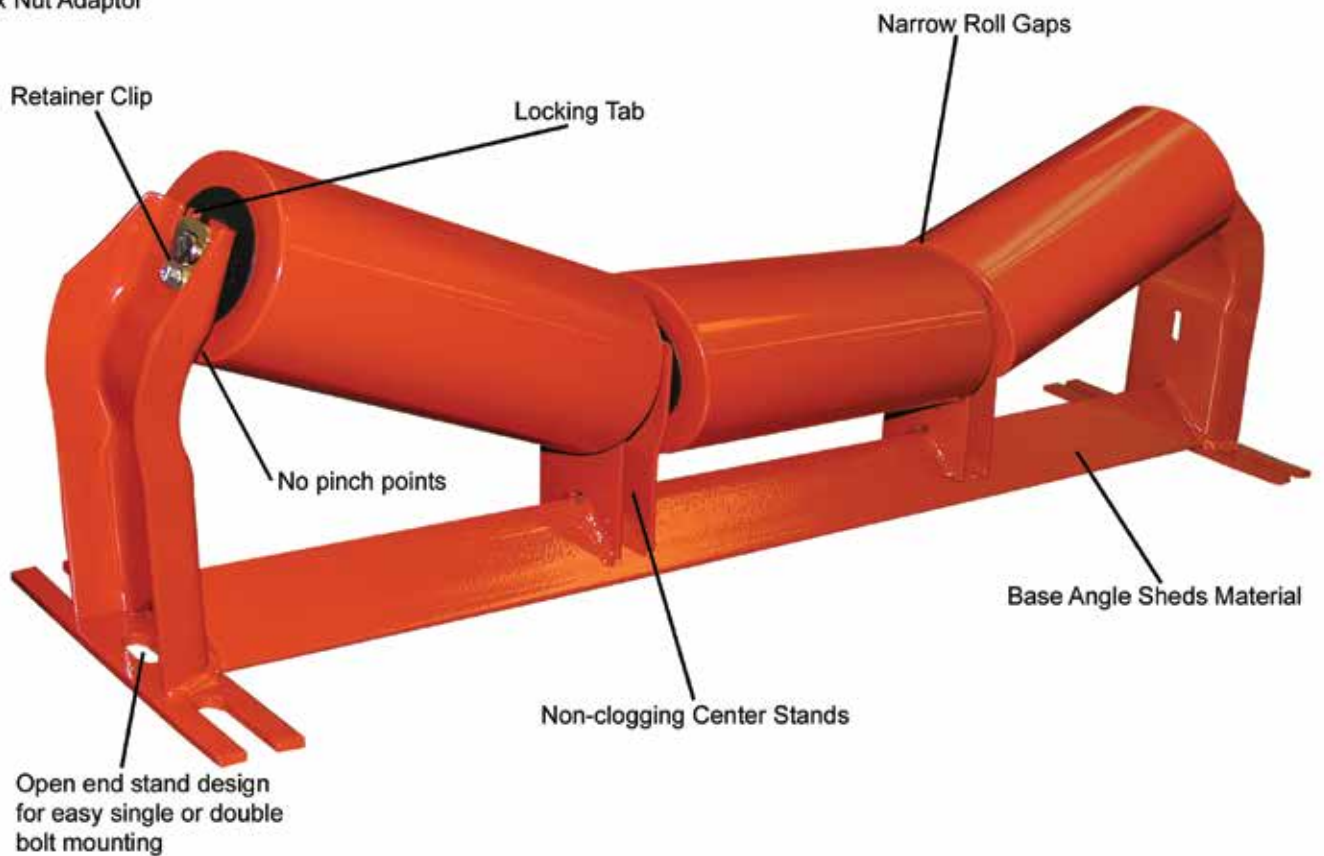

The color orange on conveyor idlers is a Federally Registered trademark of Superior Industries, Inc. QD® is a registered trademark of Emerson Electric Co. XT® is a registered trademark of Van Gorp Corp.

Superior Industries | Idler Catalog

Superior Idlers

- ▶ Styles
- ▶ Ordering Guide
- ▶ Roll Interchange

CEMA B

- ▶ Troughing Idlers – Equal Length Rollers
- ▶ Troughing Idlers – Rubber Cushion Impact
- ▶ Urathon® Return Roll
- ▶ Return Idlers
- ▶ Flat Idlers
- ▶ Return Idlers – Rubber Cushion
- ▶ Flat Idlers – Rubber Cushion
- ▶ Troughing Idlers – Self-Aligning
- ▶ Return Idlers – Self-Aligning
- ▶ Offset Center Roll Idlers
- ▶ Channel Mount Idlers
- ▶ Channel Mount Impact Idlers

CEMA C

- ▶ Troughing Idlers – Equal Length Rollers
- ▶ Return Idlers
- ▶ Flat Idlers
- ▶ Garland Idlers
- ▶ Troughing Idlers – Rubber Cushion Impact
- ▶ Return Idlers – Rubber Cushion
- ▶ Flat Idlers – Rubber Cushion
- ▶ V-Return Idlers
- ▶ Urathon Return Rolls
- ▶ Troughing Idlers – Self-Aligning
- ▶ Return Idlers – Self-Aligning
- ▶ Troughing Idlers – Feeder / Picking
- ▶ Troughing Idlers – Unequal Length Rolls
- ▶ Offset Center Roll Idlers
- ▶ Channel Mount Idlers
- ▶ Low Profile Standard Mount
- ▶ Channel Mount Impact Idlers

CEMA D

- ▶ Troughing Idlers – Equal Length Rolls
- ▶ Return Idlers
- ▶ Flat Idlers
- ▶ V-Return Idlers
- ▶ Troughing Idlers – Rubber Cushion Impact
- ▶ Return Idlers – Rubber Cushion
- ▶ Flat Idlers – Rubber Cushion
- ▶ Urathon Return Rolls

- ▶ Troughing Idlers – Self-Aligning
- ▶ Return Idlers – Self-Aligning
- ▶ Feeder / Picking Idlers
- ▶ Troughing Idlers – Unequal Length Rollers

CEMA E

- ▶ Troughing Idlers – Equal Length Rollers
- ▶ Troughing Idlers – Rubber Cushion Impact
- ▶ Return Idlers – Rubber Cushion
- ▶ Troughing Idler – Self-Aligning
- ▶ Return Idlers
- ▶ Flat Idlers – Rubber Cushion
- ▶ Flat Idlers
- ▶ Return Idlers – Self-Aligning
- ▶ Urathon Return Rolls
- ▶ V-Return Idlers

CEMA F

- ▶ Troughing Idlers – Equal Length Rollers

OTHER STYLES

- ▶ Component Parts & Replacement Rolls
- ▶ CEMA B & C Replacement Rolls
- ▶ CEMA D & E Replacement Rolls
- ▶ 81 Series CEMA C Regreaseable Idlers
- ▶ 91 Series CEMA D Regreaseable Idlers
- ▶ Regreaseable Idler Parts
- ▶ 40 Series
- ▶ CB504 Series
- ▶ Component Accessories
- ▶ Navigator® Training Idlers
- ▶ Return Guides
- ▶ 80/81 & 90/91 Hex Style Roll Guard
- ▶ Slotted Shaft Return Guard
- ▶ Beater Bar Return Roll
- ▶ Live Shaft Rollers
- ▶ Side Guide Idlers
- ▶ Vertical Side Guide Roll
- ▶ Urethane Vertical Side Guide Roll
- ▶ Stub Roll Idlers
- ▶ Variable Pitch Idlers
- ▶ Wire Rope Pitch
- ▶ Rubber Lagged Conveyor Rollers
- ▶ Sealing System
- ▶ Impact Beds
- ▶ Return & Flat Bracket Styles
- ▶ Specialized Designs
- ▶ Idler Selection Procedure



1-800-437-9074 | www.superior-ind.com