



## QUICK SPECS

Operating Temp: -4°F to 140°F

Discharge Period: 1-12 months

Dimensions: Approx. 2.5" x 5.5"



# AUTO GREASER

Temperature Compensating Electrochemical Lubrication System

- **Simple to set**, install and maintain with a highly intuitive operating menu.
- Lubricates equipment while it is running to provide **optimal lubricant exchange**.
- **Reduces work load** by automating an otherwise manual process.
- Continues to lubricate **without the need for shutdown** and isolation.

# FEATURES

- 1/ AUTO GREASER CONTROL UNIT
- 2/ LC UNIT WITH INTEGRATED BATTERY
- 3/ BUILT-IN ROBUST SUPPORT FLANGE WITH 1/4" NPT OUTSIDE THREAD
- 4/ GAS GENERATING CELL
- 5/ LUBRICANT
- 6/ DISPLAY (DISCHARGE PERIOD + FUNCTION)
- 7/ PUSH BUTTON PROGRAMMING
- 8/ RE-USABLE CONTROL UNIT

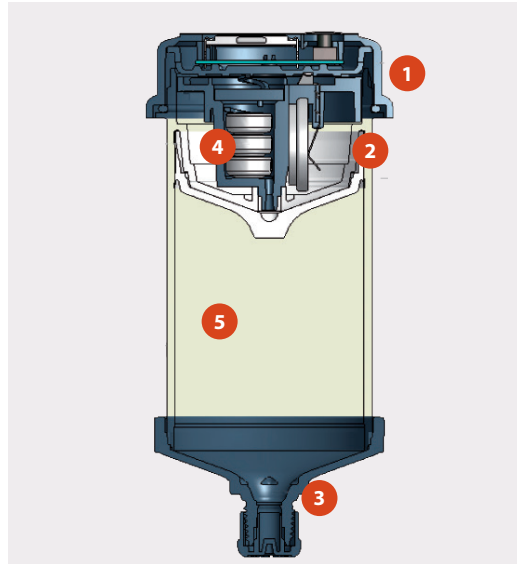

LUBRICATOR CARTRIDGE WITH CAP



CAP

# PART NUMBER GUIDE

## REPLACEMENT PARTS

Part Number	Description
03-03003	Lube Cart. Kit, Cap, Dust Cover
03-03002	Lubricator Cartridge, Dust Cover
03-03001	Cap, Auto Lubricator
08-02768	Black Pipe Nipple <b>A</b>
08-02569	Black Tee-Pipe <b>B</b>
08-10025	Adaptor <b>C</b>



45° ELBOW AND 90° TEE AVAILABLE



TOP VIEW OF STEEL ADAPTOR



BOTTOM VIEW OF STEEL ADAPTOR